

SJVN ARUN-3 POWER DEVELOPMENT COMPANY Pvt. Ltd.
(A Subsidiary of SJVN Ltd. Registered in Nepal)



ARUN-3 HYDRO ELECTRIC PROJECT, NEPAL
TENDER DOCUMENT

TENDER No.: CONDUCTOR PACKAGE (CD03) /2023

TENDER DOCUMENT FOR “CONDUCTOR PACKAGE (CD03) FOR SUPPLY OF ACSR MOOSE CONDUCTOR FOR PART OF DIDING – DHALKEBAR – BATHNAHA TRANSMISSION LINE CORRESPONDING TO TOWER PACKAGE- TW02 ASSOCIATED WITH ARUN-3 HEP IN NEPAL”

Place: Nepal

January, 2023

TABLE OF CONTENTS

| Section | Description |
|---|--|
| Volume-I: Conditions of Contract | |
| Section-I | Notice Inviting Tender (NIT)/Invitation for Bids (IFB) |
| Section-II | Instructions to Bidders (ITB) |
| Section-III | Bid Data Sheet (BDS) |
| Section-IV | General Conditions of Contract (GCC) |
| Section –V | Special Conditions of Contract (SCC) |
| Section –VI | Sample Forms and Procedures (FP) |
| Volume-II : Technical Specification | |
| Section-I | GENERAL INFORMATION AND SCOPE |
| Section-II | TECHNICAL SPECIFICATION FOR ACSR CONDUCTOR |
| Section-III | MANUFACTURING QUALITY PLAN |
| Volume-III : Bid Form, Price Schedules & Technical Data Sheets | |
| Section-I | BID FORM & TECHNICAL DATA SHEETS FOR ENVELOPE-I |
| Section-II | BID FORM & PRICE SCHEDULES FOR ENVELOPE-II |

VOLUME-I

SECTION – I

**NOTICE INVITING TENDER (NIT)/INVITATION FOR BIDS
(IFB)**

NOTICE INVITING TENDER (NIT)/INVITATION FOR BIDS (IFB)

Ref.No.: SAPDC/P&C/Arun-3HEP/CD03/2023-81

Dated: 06.02.2023

- 1.1. SJVN Arun-3 Power Development Company Private Limited (SAPDC), a company registered under Nepalese Companies Act 2063 and having its offices at SAPDC, Arun-3 HEP, Satluj Bhawan, Arun Sadan, Tumlingtar, Distt. Sankhuwasabha, Nepal & SAPDC, Arun-3 HEP, 3rd Floor, Citizen Investment Trust(CIT) Building, Near to Investment Board of Nepal (IBN), New Bhaneshwor, Kathmandu invites sealed bids in single stage two envelope bid system from the eligible Bidders from **India/Nepal** for “**supply of ACSR MOOSE Conductor for part of Diding – Dhalkebar – Bathnaha Transmission Line corresponding to Tower Package- TW02; associated with Arun-3 HEP in Nepal**”.

(GLOBAL COMPETITIVE BIDDING)

(Subject Bidding is applicable for **Indian and Nepalese Bidders** in line with terms and conditions of the Bidding Documents)

(SINGLE STAGE TWO ENVELOPE BIDDING UNDER E-PROCUREMENT)

DATE OF ISSUANCE OF NIT/IFB : **06.02.2023**

SPECIFICATION NO(S). : **SAPDC/P&C/Arun-3HEP/CD03/2023**

FUNDING : DOMESTIC (by SAPDC)

SAPDC, invites bids from eligible bidders for the following package for this project on Global Competitive Bidding basis (limited to Indian & Nepalese Bidders only) under e-procurement.

Interested bidders have to register themselves on the e-portal i.e <https://sjvn.nic.in>. The detail of registration process & fee, bidding process etc. are available under the e-Tendering & Reverse auction portal & bidder Manual also available on <https://sjvn.nic.in> under Tender Management system section (where the e-Tendering & Reverse auction portal is also available).

Bidder may please note for proper submission of the bid, the bidder is responsible and they are expected to apprise themselves adequately for the procedure and provisions available on the portal for the same directly from Purchaser in no case shall be responsible for any issues related to timely or properly uploading/submission of the bid.

1.2. Brief Detail & Time Schedule:-

| Sl. No. | Description | |
|---------|---|--|
| 1.2.1 | Name of Work | Conductor Package(CD03) for Supply of ACSR MOOSE Conductor for part of Diding – Dhalkebar – Bathnaha Transmission Line corresponding to Tower Package- TW02; associated with Arun-3 HEP in Nepal |
| 1.2.2 | NIT/IFB No. | SAPDC/P&C/Arun-3HEP/CD03/2023-81 |
| 1.2.3 | NIT/IFB Date | 06.02.2023 |
| 1.2.4 | Cost of Tender Document/ cost of Bidding Documents/Tender document cost | <p>NPR 10,000/- (For Nepalese bidders) or INR 7,000 equivalent to NPR 11,200/- (For Indian bidders) in the form of Manager's cheque (In original) (issued by a "A" Class Nepalese Bank shall only be acceptable) payable at Khandbari, Nepal in favour of SJVN Arun-3 Power Development Company Pvt. Ltd.</p> <p>Any bid not accompanied by an acceptable Cost of Tender Document shall be rejected by SAPDC as non-responsive.</p> <p>Alternatively, payment against Cost of Tender Document may be made directly in the bank account of SAPDC as mentioned below:</p> <p>NPR Account Details: Everest Bank Limited Name: SJVN Arun-3 Power Development Company Pvt. Ltd. Acc. No. 00800105200477 Swift Code: EVBLNPKA</p> <p>However, if Bidder/Firm opt for submission of Tender document cost directly in the bank account of SAPDC, then the documentary evidence/ proof of same (swift statement/ transfer statement/ account statement) has to be submitted along with technical bid in Part-I(Envelope-I).</p> |

| Sl. No. | Description | |
|---------|--|--|
| 1.2.5 | Earnest Money Deposited (EMD)/Bid Security | <p>NPR 2,59,20,000/- only (For bidders who choose to submit the EMD in NPR) or INR 1,62,00,000/- only (For bidders who choose to submit the EMD in INR) shall be required to be submitted with the proposal (In Envelope-I i.e Along with Technical bid) in either of the form:</p> <p>i. Bank Guarantee in favor of SJVN Arun-3 Power Development Company Pvt. Ltd. from any "A" class Bank in Nepal for the amounts expressed in Nepalese Rupees (NPR). The Bank Guarantees in equivalent INR amount shall be acceptable only if these are issued by a Scheduled Bank of India duly counter guaranteed by any A class bank in Nepal.</p> <p>Bank Guarantee for EMD in original shall be submitted along with the proposal. Bank Guarantee shall be in the format provided in tender document (Section-VI, Volume-I, Sample forms and Procedures). EMD shall remain valid for a period of 30 days beyond the original validity period of the bid/proposal (i.e 210 days from the last date of submission of bid) or beyond any period of extension subsequently requested under ITB Clause 14.2.</p> <p>or</p> <p>ii. FDR in original (issued by a "A" Class Nepalese Bank/Scheduled Bank of India shall only be acceptable) duly pledged in favour of SJVN Arun-3 Power Development Company Pvt. Ltd.</p> <p>or</p> <p>iii. Manager's cheque in original (issued by a "A" Class Nepalese Bank shall only be acceptable) in favour of SJVN Arun-3 Power Development Company Pvt. Ltd. payable at Khandbari.</p> <p>or</p> <p>iv. Alternatively, payment against EMD may also be made directly in the following account of SJVN Arun-3 Power Development Company Pvt. Ltd. However, proof of same shall be submitted by the Firm/agency with the Proposal in Part-I (Envelope-I): NPR Account Details: Everest Bank Limited Name: SJVN Arun-3 Power Development Company Pvt. Ltd. Acc. No. 00800105200477 Swift Code: EVBLNPKA</p> <p>Bidders are advised and shall be responsible to ensure the receipt of net amount (excluding bank transfer charges) in above account before last date of submission of bids.</p> <p>Any bid not accompanied by an acceptable Earnest Money Deposit shall be rejected by SAPDC as non-responsive.</p> <p>However, if Bidder/Firm opt for submission of Earnest Money Deposited (EMD)/Bid Security directly in the bank account of SAPDC, then the documentary evidence/ proof of same (swift statement/ transfer statement/ account statement) has to be submitted along with technical bid in Part-I(Envelope-I).</p> |
| 1.2.6 | Pre-Bid Meeting | <p>Shall be intimated later (if required) separately on websites (www.sapdc.com.np, www.sjvn.nic.in and www.eprocure.gov.in) only.</p> <p>Further, the Bidder's designated representatives are invited to attend a pre-bid meeting (if required), which will take place in person or through Video Conferencing (Mode of Pre-bid Meeting shall be as decided by SAPDC). The web link to join the meeting shall be shared before the scheduled date of the meeting</p> |

| Sl. No. | Description | |
|---------|--|---|
| 1.2.7 | Last Date and Time for submission of Bids | 27.02.2023 upto 15:00 Hrs |
| 1.2.8 | Date & Time of Opening of Techno-Commercial Bids. | 01.03.2023 at 16:00 Hrs. |
| 1.2.9 | Place for submission of Bids (Hard Copy part i.e Technical bid under Envelope-I). However, Soft copy/Scanned copy of technical bid shall also to be uploaded/submitted on SJVN e-portal. Further, price bid Under Envelope-II shall be submitted only through SJVN e-portal (by filling price part in electronic form/template & uploading soft/scanned copy of Dully filled, Signed & stamped of bid form & Schedules under Envelope-II) (Not in Hard copy) | <p>O/o Company Secretary, SAPDC, Arun-3 HEP, 3rd Floor, Citizen Investment Trust(CIT) Building,Near to Investment Board of Nepal(IBN), New Bhaneshwor, Kathmandu, Nepal. Mob No. +977-9819822967.</p> <p style="text-align: center;">OR</p> <p>O/o Chief Engineer (P&C), SAPDC, Arun-3 HEP, Satluj Bhawan, Arun Sadan, Tumlingtar, Distt. Sankhuwasabha, Nepal Ph. +977-29-575154, Mob.: +977-9852099789/+91-9816072198.</p>  |
| 1.2.10 | Place for Opening of Bids Technical bid: The bids shall be opened submitted through online portal/physical copy. | O/o Chief Engineer (P&C) SAPDC, Satluj Bhawan, Arun Sadan, Tumlingtar, Distt. Sankhuwasabha, Nepal Ph. +977-29-575154,+977-9852099789/+91-9816072198 |

| Sl. No. | Description | |
|---------|--|---|
| 1.2.11 | Date and Time for Opening of Price Bid (s) | To be intimated separately on websites (www.sapdc.com.np , www.sjvn.nic.in and www.eprocure.gov.in) only. |
| 1.2.12 | Period of Bid Validity | The bids shall remain valid for acceptance for a period of 180 days from the date of opening of Techno-Commercial Bids. |
| 1.2.13 | Currency of Bids | Indian Rupees (INR)/Nepalese Rupee (NPR) |

- 1.3. The bidding document containing the details of submission requirement, brief scope of works/services, General Conditions of Contract etc. can be downloaded from websites www.sapdc.com.np, www.sjvn.nic.in and www.eprocure.gov.in. The bidders may submit their bid (**Hard Copy part i.e Technical bid under envelope-I**) either by post/courier or physically in the tender box kept as per Sr. No. 1.2.9 herein-above prior to the last date for submission of bids. Bids of those Bidders who have submitted the requisite tender document fee and EMD acceptable to Employer only shall be considered for bid evaluation. However, Soft copy/Scanned copy of technical bid shall also to be uploaded/submitted on SJVN e-portal. Further, price bid Under Envelope-II shall be submitted only through SJVN e-portal (by filling price part in electronic form/template & uploading soft/scanned copy of Dully filled, Signed & stamped of bid form & Schedules under Envelope-II) (Not in Hard copy).
- 1.4. SJVN Arun-3 Power Development Company Pvt. Ltd. (SAPDC), a company incorporated and registered on 25.04.2013 as a private limited company under the Nepalese Companies Act 2063 duly floated by single shareholder company of SJVN Ltd. (A CPSE under the Govt. of India), having its offices at SAPDC, Arun-3 HEP, Satluj Bhawan, Arun Sadan, Tumlingtar, Distt. Sankhuwasabha, Nepal & SAPDC, Arun-3 HEP, 3rd Floor, Citizen Investment Trust(CIT) Building, Near to Investment Board of Nepal (IBN), New Bhaneshwor, Kathmandu (hereinafter referred to as 'SAPDC' / 'Owner' / 'Employer' / 'Purchager') has decided to set up, as an Owner, 400 kV D/C (Quad Moose) Diding – Dhalkebar - Bathnaha Transmission Line associated with Arun-3 HEP in Nepal.
- 1.5. SAPDC, invites sealed bids from eligible bidders for the following package for this project on Global Competitive Bidding basis (limited to Indian & Nepalese Bidders only) under e-procurement.

Conductor Package CD03 for supply of ACSR MOOSE Conductor for part of Diding – Dhalkebar – Bathnaha Transmission Line corresponding to Tower Package-TW02; associated with Arun-3 HEP in Nepal.

This Invitation for Bids extended through media, website or written communication or by any other means, and issuance of Bidding Documents shall not be construed to mean that the prospective bidders to whom the Invitation for Bids has been extended and/or Bidding Documents have been issued is deemed to be an eligible bidder. The eligibility of the bidders shall be determined as per the provisions of Bidding Documents.

- 1.6. For these package bids from joint venture is not permitted.

- 1.7. Bidders should not have been banned/ de-listed/ black listed/ debarred from business by Government of Nepal or any of its Government Department during last 03 (three) years on grounds of corrupt/fraudulent practices and/or due to non-performance and/or by Ministry of Power, Government of India/SJVN/SAPDC on any grounds.
- 1.8. The scope of work covered under the subject package shall include: design, manufacture, testing and supply on final destination at destination site basis of Conductors for the following Transmission Line(s) in Nepal, as detailed in the Bidding Documents:

| Package | Name of Transmission Lines | Quantity of Conductors (in Kms) |
|---------|---|---------------------------------|
| CD03 | Tower Package- TW02 for portion comprising of 400 kV D/C (Quad Moose) Diding – Dhalkebar – Bathnaha Transmission Line (Approx. 124km from Bathnaha) | 2799 |

The above scope of work is indicative and the detailed scope of work is given in the Technical Specification (Volume-II) of the Bidding documents.

- 1.9. The delivery schedule for subject packages shall be the period as specified in ITB Sub-Clause 24.1(c).
- 1.10. Bidding will be conducted through Bidding procedures as per the provisions of Bidding Documents/Tender document and the contract shall be executed as per the provisions of the Contract. The respective rights of the SAPDC/Purchaser and the Bidder/Supplier shall be governed by the Bidding Documents/Contract signed between the Purchaser and the Supplier for the respective packages.
- 1.11. The detailed Qualifying Requirements (QR) are given in the Bidding Document.
- 1.12. The complete Bidding Documents including tender drawings, if any, are available at www.sapdc.com.np, www.sjvn.nic.in and www.eprocure.gov.in

The Bidding Documents are meant for the exclusive purpose of bidding against this specification and shall not be transferred to any other party or reproduced or used otherwise for any purpose other than for which they are specifically uploaded.

Bidder may please note for proper submission of the bid, the bidder is responsible and they are expected to apprise themselves adequately for the procedure and provisions as per tender document SADPDC/Purchaser in no case shall be responsible for any issues related to timely or properly submission of the bid.

- 1.13. A pre-bid meeting(if required) to clarify the bidders various issues raised in accordance with clause 6.2 of ITB shall be intimated later (if required) separately on websites (www.sapdc.com.np, www.sjvn.nic.in and www.eprocure.gov.in) only. Further, the Bidder's designated representatives are invited to attend a pre-bid meeting(if required), which will take place in person or through Video Conferencing(Mode of Pre-bid Meeting shall be as decided by SAPDC). The web link to join the meeting shall be shared before the scheduled date of the meeting.

- 1.14. A Single Stage Two Envelope Bidding Procedure will be adopted and will proceed as detailed in the Bidding Documents.

Soft Copy Part of the Bids must be uploaded under Single Stage Two Envelope Bidding Procedure on the portal at or before time given in NIT/IFB. The e-Procurement system would not allow any late submission of bids through the portal after due date & time as specified.

Hard Copy (i.e Technical bid part under envelope-I): Sealed bid must be submitted at the address & time given in NIT/IFB. SAPDC shall not be responsible for any postal delay in respect of submission of the bid.

In case Hard copy part of the bid i.e Technical bid Under 1st Envelope-I is not received till the deadline for submission of the same prescribed by the Purchaser, but the bidder has uploaded the soft/scanned copy of the technical bid, the soft/scanned copy of bid. The uploaded technical bid on the portal shall be opened and such bids may be rejected during preliminary examination.

First Envelope i.e. Techno -Commercial Part shall be opened on date & time as per NIT/IFB in the presence of the bidders' representatives who choose to attend in person at the address given in NIT/IFB/BDS or may be viewed by the bidders by logging in to the portal. Second Envelope i.e. Price Part shall be opened at the time and date given in the intimation for opening of Second Envelope in accordance with Clause 25 of ITB. The opening of same may be viewed by the bidders by logging in to the portal.

- 1.15. At any time before the submission of bids, SAPDC may modify/amend the bidding documents and extend the last date of submission/opening of the Proposal and any other key dates by issuing a corrigendum/addendum and such corrigendum/addendum to this notice as well as to the bidding document shall be available on the aforesaid websites only. As such the Bidders are advised to visit the above websites regularly.
- 1.16. Deleted.
- 1.17. Employer reserves the right to cancel the tendering process at any time without assigning any reason. SAPDC reserves the right to reject any or all the Bids without assigning any reason thereof.
- 1.18. Pre-Bid Clarifications: Bidders may submit their clarifications regarding the tender document, if any, in writing either by email or post and it must be received to Tender Inviting Authority Three (03) day prior to the date of the Pre-Bid Meeting.
- 1.19. No Deviation Bid: Bidder may note that Bid shall be submitted on the basis of "NO DEVIATION" and shall be in full compliance to the requirements of Tender Document. The bids with deviations shall be considered as nonresponsive and may be liable for rejection.
- 1.20. Bid Submission: The bids are to be submitted on SJVN e-portal. The technical bid under Envelope-I is to be submitted in hard copy as well as upload the scanned/soft copy of the same on e-portal i.e <https://sjvn.nic.in>. However price bid Under Envelope-II shall be submitted only through SJVN e-portal (by filling price part in electronic form/template & uploading soft/scanned copy of Dully filled, Signed & stamped of bid form & Schedules under Envelope-II) (Not in Hard copy),

any other mode of submission of price bid part shall not be accepted.

- 1.21. The SAPDC reserves the right to conduct e-Reverse Auction (e-RA) in accordance with clause 29 of ITB.
- 1.22. SAPDC reserves the right to cancel/withdraw this invitation for bids without assigning any reason and shall bear no liability whatsoever consequent upon such a decision.
- 1.23. For any enquiry/clarification/ correspondence etc. with regard to the above bidders may contact at the following address
(By Post/In Person/E-Mail)

Chief Engineer (Procurement and Contracts)

SJVN Arun-3 Power Development Company,

Satluj Bhawan, Arun Sadan, Tumlingtar

District-Sankhuwasabha, Nepal

Contact No. +977-29-575154/+977-9852099789/+91-9816072198

e-mail Address: pnc.sapdc@gmail.com

- 1.24. **Integrity Pact:** To improve transparency and fairness in the tendering process, SAPDC is implementing Integrity Pact. To improve transparency and fairness in the tendering process the Employer is implementing Integrity Pact. Integrity Pact is deemed as part of the contract so that the prospective bidders are bound by its provisions.

The Integrity Pact, signed by all the prospective Bidders and the Employer, shall commit the persons/officials of both the parties, not to exercise any corrupt/fraudulent/collusive/coercive practices in the Tendering process and also during implementation of the Contract. Only those Bidders who have entered into Integrity Pact with the Employer shall be eligible to participate in the bidding process. Bidders signing Integrity Pact shall not approach the Courts while representing the matters to IEMs and he/she will await their decision in the matter. Entering into Integrity Pact as per Performa (Enclosed at Schedule-F) is a basic qualifying requirement. In case of JV, each partner of JV shall sign Integrity Pact with the Employer. In case of sub-contracting, the Principal contractor shall be responsible for adoption of Integrity Pact by the sub-contractor.

To oversee the compliance of obligation under the Integrity Pact, a panel of Independent External Monitor(s) (IEMs) have been appointed by concerned authority. The Contact address of IEMs are as under:

| Sl. No. | Name of IEMs | Address of IEMs |
|---------|---|---|
| 1 | Sh. S.P. Srivastava, IPS (Retd.) | 1/125, Vineet Khand, Gominagar, Lucknow, UP-226010 Email: sps_ips@yahoo.com |
| 2 | Smt. Archana Pandey Tiwari, IRS (Retd.) | C-32, Nangal Dewat, Vasant Kunj, New Delhi-110070 Email: |



| | |
|--|--|
| | ampandey2001@yahoo.com |
|--|--|

The Integrity Pact duly signed on behalf of SAPDC is enclosed at Schedule-F of the Bid Document. The Integrity Pact shall be downloaded, printed and signed by the bidder and the hard copy shall be submitted in Part-I (Envelope-I).

- 1.25. The successful bidder shall submit duly executed Integrity Pact on Plain Paper prior to signing of Contract Agreement.



VOLUME-I

SECTION – II

INSTRUCTIONS TO BIDDERS (ITB)

TABLE OF CLAUSES

Preamble

A. INTRODUCTION

1. SOURCE OF FUNDS
2. ELIGIBLE BIDDERS
3. ELIGIBLE GOODS AND RELATED SERVICES
4. COST OF BIDDING

B. THE BIDDING DOCUMENTS

5. CONTENT OF BIDDING DOCUMENTS
6. CLARIFICATION OF BIDDING DOCUMENTS; AND PRE-BID MEETING
7. AMENDMENT OF BIDDING DOCUMENTS

C. PREPARATION OF BIDS

8. LANGUAGE OF BID
9. DOCUMENTS COMPRISING THE BID
9. DOCUMENTS COMPRISING THE BID
10. BID FORM AND PRICE SCHEDULES
11. BID PRICES
12. BID CURRENCIES
13. BID SECURITY
14. PERIOD OF VALIDITY OF BID
15. FORMAT AND SIGNING OF BID
17. DEADLINE FOR SUBMISSION OF BIDS
18. LATE BIDS
19. MODIFICATION AND WITHDRAWAL OF BIDS

E. BID OPENING AND EVALUATION

20. OPENING OF FIRST ENVELOPE BY PURCHASER
21. CLARIFICATION OF BIDS
22. PRELIMINARY EXAMINATION OF FIRST ENVELOPE
23. QUALIFICATION
24. EVALUATION OF TECHNO-COMMERCIAL PART (FIRST ENVELOPE)
25. OPENING OF SECOND ENVELOPE BY PURCHASER
26. CONVERSION TO SINGLE CURRENCY
27. EVALUATION OF SECOND ENVELOPE (PRICE PART)
28. PURCHASE/DOMESTIC PREFERENCE
29. E-REVERSE AUCTION (E-RA)
30. CONFIDENTIALITY AND CONTACTING THE PURCHASER

F. AWARD OF CONTRACT

31. AWARD CRITERIA
32. PURCHASER'S RIGHT TO ACCEPT ANY BID AND TO REJECT ANY OR ALL BIDS
33. NOTIFICATION OF AWARD
34. SIGNING THE CONTRACT AGREEMENT
35. PERFORMANCE SECURITY
36. FRAUD AND CORRUPTION



INSTRUCTIONS TO BIDDERS (ITB)

Preamble

This section (Section-II) of the Bidding Documents provides the information necessary for bidders to prepare responsive bids, in accordance with the requirements of the Purchaser. It also provides information on bid submission and uploading the bid on portal <https://sjvn.nic.in> under Tender Management system section, on line bid opening, evaluation and on contract award. This Section (Section II) contains provisions that are to be used unchanged unless Section III, which consists of provisions that supplement, amend, or specify in detail, information or requirements included in Section II and that are specific to each procurement, states otherwise. If there is a conflict between the provisions of Section – II & Section – III, the provisions of Section – III shall prevail.

However, provisions governing the performance of the Supplier, payments under the contract or matters affecting the risks, rights and obligations of the parties under the contract are not included in this section but instead under Section – IV: General Conditions of Contract and/or Section – V: Special Conditions of Contract.

Further in all matters arising out of the provisions of this Section – II and the Section – III of the Bidding Documents. The Contract shall be governed by and interpreted in accordance with laws of Nepal and the Courts of Nepal shall have exclusive jurisdiction in all matters arising under this Contract.

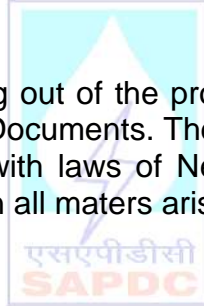

A. Introduction

1. Source of Funds

- 1.1 The Owner named in the **BDS** intends to use domestic funding (Owner's Internal Resources/Domestic Borrowings/Bonds) for this Project.

All eligible payments under the contract for the packages for which this Invitation for Bids is issued shall be made by the Purchaser named in the BDS.

2. Eligible Bidders

- 2.1 This Invitation for Bids, issued by the SAPDC/Purchaser, is open to all firms including company(ies), Government owned Enterprises from India and Nepal, who are registered and incorporated in their respective countries as per the local act, barring Government Department as well as those firms against whom sanction for conducting business is imposed by Government of India/Nepal and barring those firms with whom business is banned by the Purchaser/ SJVN & its Subsidiaries. Accordingly Bids are invited from the following Firms:

Sole Indian bidders

Sole Nepalese bidders

Indian Bidders for the purpose of this Contract shall be treated as foreign Bidder.

Bidders should not have been banned/ de-listed/ black listed/ debarred from business by Government of Nepal or any of its Government Department during last 03 (three) years on grounds of corrupt/fraudulent practices and/or due to non-performance and/or by Ministry of Power, Government of India/SJVN & its Subsidiaries /SAPDC on any grounds.

- 2.2 A Bidder shall not have a conflict of interest. All Bidders found to have a conflict of interest shall be disqualified. A Bidder may be considered to have a conflict of interest with one or more parties in this bidding process, if :

- (a) they have a controlling partner in common; or
- (b) they receive or have received any direct or indirect subsidy from any of them; or
- (c) they have the same legal representative for purposes of this bid; or
- (d) they have a relationship with each other, directly or through common third parties, that puts them in a position to have access to information about or influence on the bid of another Bidder, or influence the decisions of the Purchaser/SJVN & its Subsidiaries regarding this bidding process; or
- (e) A Bidder submits more than one bid in this bidding process, either individually [including bid submitted as a agent/authorized representative

on behalf of one or more manufacturer(s) or through Licensee – Licensor route, wherever permitted as per the provision of Qualification Requirement for the Bidders in Annexure – A (BDS)] or as a partner in a joint venture, except for alternative offers permitted under ITB Clause 9.3. This will result in the disqualification of all such bids. However, this does not limit the participation of a Bidder as a subcontractor in another bid, or of a firm as a subcontractor in more than one bid; or

- (f) A Bidder or any of its affiliates participated as a consultant in the preparation of the design or technical specifications of the Goods and related services that are the subject of the bid; or
- (g) A Bidder or any of its affiliates has been hired (or is proposed to be hired) by the Purchaser/ SJVN & its Subsidiaries as Project Manager for the contract.

2.3 The Bidder, directly or indirectly shall not be a dependent agency of the Purchaser/ SJVN & its Subsidiaries.

2.4 In case a prequalification process has been conducted prior to the bidding process, this bidding is open only to prequalified Bidders.

3. Eligible Goods and Related Services

3.1 For the purposes of these Bidding Documents, the words “goods” includes commodities, raw materials, machinery, equipment and industrial plants and “related services” and “related services” includes services such as insurance, installation, training and initial maintenance.

3.2 All the Goods and Related Services to be supplied under the Contract shall have their origin in any country barring those countries against whom sanction for conducting business is imposed by Government of India/Nepal and barring those firms with whom business is banned by the Purchaser/ SJVN & its Subsidiaries.

3.3 For purposes of this clause, “country of origin” means the place (India/Nepal) where the goods have been mined, grown, produced, manufactured or processed; or through manufacturing, processing or substantial assembling of components, a commercially recognized product results that is substantially different in basic characteristics or in purpose or utility from its components.

4. Cost of Bidding

4.1 The Bidder shall bear all costs associated with the preparation and submission of its bid including post-bid discussions, technical and other presentations etc., and the Purchaser will in no case be responsible or liable for these costs, regardless of the conduct or outcome of the bidding process.

- 4.2 The bidder has to ensure his registration on e-portal i.e on <https://sjvn.nic.in> for bidding The detail of registration process & fee, bidding process etc. are available under the e-Tendering & Reverse auction portal bidder Manual also available on <https://sjvn.nic.in> under Tender Management system section (where the e-Tendering & Reverse auction portal is also available).

B. The Bidding Documents

5. Content of Bidding Documents

- 5.1 The goods and related services required, bidding procedures, contract terms and technical requirements are prescribed in the Bidding Documents. The Bidding Documents comprise of the following and shall include amendments, if any, thereto:

| | |
|-------------|---|
| VOLUME – I: | Conditions of Contract Section I Invitation for Bids (IFB) |
| Section II | Instructions to Bidders (ITB) Section III Bid Data Sheet (BDS) |
| Section IV | General Conditions of Contract (GCC) Section V Special Conditions of Contract (SCC) Section VI Sample Forms and Procedures (FP) |
| | 1. Bid Form & Price Schedule |
| | 1.1 Bid Form |
| | 1.2 Price Schedule |
| | 2. Bid Security Form |
| | 3. Form of Notification by the Purchaser to the Bank |
| | 4. Form of „Notification of Award of Contract“ |
| | 5. Form of Contract Agreement |
| | 5.1 Appendix-1: Terms and Procedures of Payment |
| | 5.2 Appendix-2: Price Adjustment |
| | 5.3 Appendix-3: Insurance Requirements |
| | 5.4 Appendix-4: Time Schedule |
| | 5.5 Appendix-5: List of Approved Subcontractors |
| | 5.6 Appendix-6: List of Document for Approval or Review |
| | 5.7 Appendix-7: Guarantees, Liquidated Damages for Non-Performance |
| | 5.8 Appendix-8: Contract Coordination Procedure |
| | 5.9 Appendix-9: Break-up of Contract Price for On-Account Payment Purpose |
| | 5.10 Appendix-10: Integrity Pact |
| | 6. Performance Security Form |
| | 7. Bank Guarantee Form for Advance Payment |

8. Form of Taking Over Certificate
9. Form of Extension of Bank Guarantee
10. Form of Power of Attorney for Joint Venture
11. Form of Joint Venture Agreement
12. Format for Evidence of Access to or Availability of Credit/ Facilities
13. Form of Material Acceptance Certificate
14. Form of Joint Undertaking by the Licensor along with the Bidder.
15. Form of Bank Guarantee for Contract Performance (to be submitted by Licensor).
16. Form of Performance Security
(To be Submitted by the Contractor Opting for submission of Performance Security with Initial Validity of 2 Years in accordance with Clause GCC 9.3.1.1)

Volume-II : Technical Specification

Volume-III : Bid Form, Price Schedules & Technical Data Sheets

- 5.2 The Bidder is expected to examine all instructions, forms, terms, specifications and other information in the Bidding Documents. Failure to furnish all information required by the Bidding Documents or submission of a bid not substantially responsive to the Bidding Documents in every respect will be at the Bidder's risk and may result in rejection of its bid.
- 5.3 Scope of Work is given in Volume-II of Bidding Documents entitled "Technical Specifications".

Utmost care has been taken by the SAPDC/Purchaser in formulating the programmed Attachments and Price Schedules. Bidders shall notify to the Purchaser Arithmetical, Logical, Formatting or any such error, if found in the same for suitable action. Irrespective of corrections made in this regard through amendment(s), if any, rectification of error for evaluation shall be carried out in accordance with stipulated provisions of Bidding Documents

- 5.4 All the Bidders shall submit a nonrefundable fee as stipulated in the NIT/IFB/BDS towards the cost of Bidding Documents/Tender document cost of NPR 10,000/- (For Nepalese bidders) or INR 7,000 equivalent to NPR 11,200/- (For Indian bidders) in the form of Manager's cheque (In original) (issued by a "A" Class Nepalese Bank shall only be acceptable) in favour of SJVN Arun-3 Power Development Company Pvt. Ltd., payable at Khandbari, Nepal. Along with the techno-commercial bid(Envelope-I) Alternatively, payment against Cost of Tender Document may be made directly in the bank account of SAPDC as mentioned below:

NPR Account Details:

Everest Bank Limited
Name: SJVN Arun-3 Power Development Company Pvt. Ltd.
Acc. No. 00800105200477
Swift Code: EVBLNPKA

However, if Bidder/Firm opt for submission of Tender document cost directly in the bank account of SAPDC, then the documentary evidence/ proof of same (swift statement/ transfer statement/ account statement) has to be submitted along with technical bid in Part-I(Envelope-I).

Bidder's failure to submit an acceptable cost of Bidding Documents along with the bid or subsequently pursuant to ITB Clause 21.1, shall lead to outright rejection of the Bid.

Any bid not accompanied by an acceptable Cost of Tender Document shall be rejected by SAPDC as non-responsive.

5.5 Deleted.

6. Clarification of Bidding Documents; Pre-Bid Clarifications and Pre-Bid Meeting

6.1 A prospective Bidder requiring any clarification of the Bidding Documents may notify the Purchaser through in writing either by email or post. at the Purchaser's mailing address indicated in the NIT/IFB/**BDS**. Similarly, if a Bidder feels that any important provision in the documents, such as those listed in ITB Sub-Clause 22.3.1, will be unacceptable, such an issue should be raised as above. The Purchaser will respond through uploading on the websites(www.sapdc.com.np, www.sjvn.nic.in and www.eprocure.gov.in/) through e-mail to any request for clarification or modification of the Bidding Documents that it receives no later than Seven (7) days (unless otherwise specified in **BDS**) prior to the original deadline for submission of bids prescribed by the Purchaser. The Purchaser shall not be obliged to respond to any request for clarification received later than the above period. Further, the mere request for clarification from the Bidders shall not be a ground for seeking extension in the deadline for submission of bids. Purchaser's response (including an explanation of the query but not identification of its source) will be uploaded on websites (i.e www.sapdc.com.np, www.sjvn.nic.in and www.eprocure.gov.in/) where the entire bidder can see clarification/reply to query.

6.2 The Bidder's designated representatives are invited to attend a pre-bid meeting(if required), which will take place in person or through Video Conferencing(Mode of Pre-bid Meeting shall be as decided by SAPDC). The web link to join the meeting shall be shared before the scheduled date of the meeting.The purpose of the meeting will be to clarify any issues regarding the Bidding Documents in general and the Technical Specifications in particular. The Bidder is requested, as far as possible, to submit any question in writing, to

reach the Purchaser not later than 03 days before the meeting. It may not be practicable at the meeting to answer questions received late, but questions and responses will be transmitted as indicated hereafter. Minutes of the meeting, including the text of the questions raised (without identifying name of the bidders) and the responses given, together with any responses prepared after the meeting, will be transmitted without delay through uploading on websites i.e www.sapdc.com.np, www.sjvn.nic.in and www.eprocure.gov.in only. Any modification of the Bidding Documents listed in ITB Sub-Clause 5.1, which may become necessary as a result of the pre-bid meeting shall be made by the Purchaser exclusively through the issue of an Addendum pursuant to ITB Clause 7 and not through the minutes of pre-bid meeting.

Non-attendance at the pre-bid meeting will not be a cause for disqualification of a bidder.

Further, Wherever the bidder finds any discrepancy, omission, ambiguity or conflict in or among the documents forwarded/uploaded or be in doubt as to their meaning and interpretation; such matter should be called to the attention of the Tender Inviting Authority, in writing either by email or post and it must be received to Tender Inviting Authority latest by one (01) day prior of the date of Pre-Bid Meeting. Any modification to the Tender Documents that may become necessary as a result of the pre-bid Clarifications shall be made by SAPDC through the issue of an Addendum pursuant to ITB Clause 7. SAPDC shall not be obliged to respond to any request for clarification received later than the above period. Further, mere request for clarification from the Bidders shall not be a ground for seeking extension in the deadline for submission of bids.

7. Amendment of Bidding Documents

- 7.1 At any time prior to the deadline for submission of bids, the Purchaser/SAPDC may, for any reason, whether at its own initiative, or in response to a clarification requested by a prospective Bidder, amend the Bidding Documents.
- 7.2 The modification to the Tender documents by issuing Addenda/Corrigendum/Amendment will be notify through only on the websites www.sapdc.com.np, www.sjvn.nic.in and www.eprocure.gov.in. No press note will be released in this regard. Therefore, the Bidders are advised to visit the site regularly. The amendments to the Bidding Documents will be binding on the bidders and the notification of the amendment, shall be deemed to be construed that such amendment(s) to the Bidding Documents have been taken into account by the Bidder in its bid.
- 7.3 In order to afford reasonable time to the prospective Bidders to take the amendment into account in preparing their bid, the Purchaser may, at its discretion, extend the deadline for the submission of bids, in which case, the Purchaser will notify through websites www.sapdc.com.np, www.sjvn.nic.in and www.eprocure.gov.in. all prospective bidders may see the extended deadline.

C. **Preparation of Bids**

8. **Language of Bid**

8.1 The bid prepared by the Bidder and all correspondence and documents exchanged by the Bidder and the Purchaser/SAPDC related to the bid shall be written in the English language, provided that any printed literature furnished by the Bidder may be written in another language, as long as such literature is accompanied by English translation of its pertinent passages, in which case, for purposes of interpretation of the bid, the English translation shall govern.

9. **Documents Comprising the Bid**

Each Bidder shall submit the followings with his bid and the bid shall be submitted as per the manner stipulated at **clause 16 of ITB** under Heading Submission of Bids:

a. **Envelope-I:** Techno-commercial bid (All the document in support of QR, Bid forms etc. except price bid part) along with EMD, cost of bid document/proof of same in case of online Bank Transfer etc. as stipulated below.

b. **Envelope-II:** Price Schedules & Bid Forms.

I. Envelope-I(Part-I): Techno-commercial bid:

Bid shall comprise of following documents to be submitted in sealed envelope, as part of First Envelope in the form of Hard copy and soft/scanned copy of same shall also be uploaded on SJVN e-portal i.e <https://sjvn.nic.in>:

- (i) Manager's cheque (In original) against Tender document cost/ Bidding Document fee of the amount as specified & in accordance with clause 5.4 of ITB/ clause 1.2.4 of NIT/IFB or proof of same in case of online Bank Transfer.
- (ii) Bid Security (BG in Original/proof of same in case of online Bank Transfer) in accordance with clause clause 1.2.5 of NIT/IFB, in separate envelope in accordance with clause 13 of ITB, Section-II
- (iii) Integrity Pact(Schedule-F) (in Original) in accordance with clause 9.3 (o) of ITB, Section-II

The Integrity Pact duly signed on behalf of SAPDC is enclosed at Schedule-F of the Bid Document. The Integrity Pact shall be downloaded, printed and signed by the bidder and the hard copy shall be submitted in Part-I (Envelope-I) as per clause 1.24 of NIT/IFB

- (iv) Power of Attorney as per Clause 9.3 (b).
- (v) In case of Bid from Joint Venture, the Joint Venture Agreement & Power of Attorney of Joint Venture Agreement, both in original
- (vi) Any other document further specified in the BDS duly signed and stamped on each page.

- (vii) All the document in support of QR, Bid forms(Ref Volume-III, Section-I) etc. except price bid part, Attachments (Attachment & Bid Form(First Envelope) including attachment to QR) as specified under the Clause 9, 9.1, 9.2, 9.3 of ITB & all the documents mentioned at 15.4 of ITB and as per manner stipulated at clause 16 of ITB under Heading Submission of Bids.

The above stated requirements are minimum and the Employer reserves the right to request for any additional information and also reserves the right to reject the proposal of any Bidder, if in the opinion of the Employer, the qualification data is incomplete or the Bidder if found not qualified to satisfactorily perform the Works.

Notwithstanding anything stated above, the Employer reserves the right to assess Bidder's capability and capacity to perform the works, should the circumstances warrant such an assessment in the overall interest of the Employer.

II. Envelope-II(Part-II): Price Schedules & Bid Forms(Second envelope):

Price Schedules (Price - Part) covering details regarding summary of price details & Bid Forms(Ref Volume-III, Section-II) & its revision covering various price schedules and bid forms for Second Envelope.

Price bid Under Envelope-II shall be submitted only through SJVN e-portal i.e <https://sjvn.nic.in> (by filling price part in electronic form/template & uploading soft/scanned copy of Dully filled, Signed & stamped of bid form & Schedules under Envelope-II) (Not in Hard copy), any other mode of submission of price bid part shall not be accepted.

Rates should be filled in both figures and words. In case of ambiguities in between the rate in figures and the rate in words, the rate quoted in words shall prevail and the amount shall be corrected accordingly. The SAPDC reserves the right to adjust arithmetical or other errors in any tender/quotation in the way which it considers suitable.

- 9.1 The bid shall be submitted by the Bidder under "Single Stage – Two Envelope" procedure of bidding as per the manner stipulated at clause 16 of ITB under Heading Submission of Bids. Under this procedure, the bid submitted by the Bidder in two envelopes - First Envelope (also referred to as Techno - Commercial Part) and Second Envelope (also referred to as Price Part) shall comprise of the following documents:

➤ First Envelope/Envelope-I(Part-I): Techno-commercial bid:

- (a) Bid Form (First Envelope) duly completed and signed by the Bidder, together with all Attachments & Technical Data Sheets(available in Volume-III) and identified in ITB Sub-Clause 9.3 below.
- (b) Following documents as mentioned at 9. I. above:
- a. Manager's cheque (In original) Tender document cost/ Bidding Document fee of the amount as specified in the in accordance with

clause 5.4 of ITB/ clause 1.2.4 of NIT/IFB or proof of same in case of online Bank Transfer

- b. Bid Security (BG in Original/proof of same in case of online Bank Transfer) in accordance with clause 1.2.5 of NIT/IFB, in separate envelope in accordance with clause 13 of ITB, Section-II
- c. Integrity Pact(Schedule-F) (in Original) in accordance with clause 9.3 (o) of ITB, Section-II

The Integrity Pact duly signed on behalf of SAPDC is enclosed at Schedule-F of the Bid Document. The Integrity Pact shall be downloaded, printed and signed by the bidder and the hard copy shall be submitted in Part-I (Envelope-I) as per clause 1.24 of NIT/IFB

- d. Power of Attorney as per Clause 9.3 (b).
- e. In case of Bid from Joint Venture, the Joint Venture Agreement & Power of Attorney of Joint Venture Agreement, both in original
- f. Any other document further specified in the BDS duly signed and stamped on each page.
- g. All the document in support of QR, Bid forms(Ref Volume-III, Section-I) etc. except price bid part, Attachments (Attachment & Bid Form(First Envelope) including attachment to QR) as specified under the Clause 9, 9.1 & 9.3 of ITB & all the documents mentioned at 15.4 of ITB and as per manner stipulated at clause 16 of ITB under Heading Submission of Bids.

➤ **Second Envelope/ Envelope-II(Part-II): Price Schedules:**

- a. Bid Form (Second Envelope) together with Price Schedules (available in (Ref Volume-III, Section-II))

Rates should be filled in both figures and words. In case of ambiguities in between the rate in figures and the rate in words, the rate quoted in words shall prevail and the amount shall be corrected accordingly. The SAPDC reserves the right to adjust arithmetical or other errors in any tender/quotation in the way which it considers suitable.

- 9.2 Bidders shall note that, they are not entitled to submit an alternative bid within the scope specified in the Technical Specification (According to the **BDS**). In such cases, bidders shall submit full details and justifications, etc., in Attachment 7 to the bid as indicated in ITB Sub-Clause 9.3 (g) below.
- 9.3 Bidder shall submit following documents (In Hard copy form as well as upload the soft/scanned copy on e-portal i.e <https://sjvn.nic.in>) wherever stipulated in the manner specified in ITB Clause 9.1 above along with its Techno - Commercial Part (First Envelope/Envelope-I(Part-I)):
 - (a) Attachment 1: Bid Security (if required) or documentary evidence in support of exemption of Bid Security (submission of Hard Copy in 'Original' for Bid Security and in 'Copy' for documentary proof in support of exemption or proof of same in case of online Bank Transfer)

A bid security or documentary evidence in support of exemption of Bid Security, in sealed separate envelope shall be furnished in accordance with 1.2.5 NIT/IFB & ITB Clause 13 & ITB Clause 16.

Bidder shall submit the hard copy & upload the soft/scanned copy of the Bid Security or documentary evidence in support of exemption of Bid Security in original.

(b) Attachment 2: Power of Attorney (*submission of Hard copy in 'Original'*)

A power of attorney, duly notarized, indicating that the person(s) signing the bid has(ve) the authority to sign the bid and thus that the bid is binding upon the Bidder during full period of its validity, in accordance with ITB Clause 14 also the documents under the below para/clause 15.4 of ITB. Bidder shall submit the hard copy & upload the soft/scanned copy of above documents (refer para 15.4 below)

(c) Attachment 3: Bidder's Eligibility and Qualifications (Copies of documentary evidence in support of Bidder's qualification). In case of Joint Venture bid, submission of Hard Copy in 'Original' of the JV Agreement and POA for JV)

In the absence of prequalification, documentary evidence establishing that the Bidder is eligible to bid in accordance with ITB Clause 2 and is qualified to perform the contract in accordance with **Annexure – A (BDS)**, if its bid is accepted.

The documentary evidence of the Bidder's eligibility to bid shall establish to the Purchaser's satisfaction that the Bidder, at the time of submission of its bid, is eligible as defined in ITB Clause 2.

The documentary evidence of the Bidder's qualifications to perform the contract, if its bid is accepted, shall establish to the Purchaser's satisfaction that the Bidder has the financial, technical, production, and other capabilities necessary to perform the contract, and, in particular, meets the experience and other criteria outlined in the Qualification Requirement for the Bidders in Annexure – A (BDS) and shall also include:

The documentary evidence defining i) the constitution or legal status; (ii) The principal place of business; (iii) The place of incorporation (for bidders who are corporations); or the place of registration and the nationality of the Owners (for applicants who are partnerships or individually-owned firms); (iv) In support of meeting the Technical experience, self-certified copy of Contract/ Award Letter and Utility/Completion Certificate.

The bidder shall furnish along with its bid a declaration as per the enclosed format from its Power of Attorney holder and Key Managerial Personnel (KMP) of the company i.e. CEO/Managing Director/

Company Secretary/ Director/ CFO/any of the partner in case of partnership firm/ any other officer entrusted with substantial powers of the management of the affairs of the company/firm, declaring the eligibility/qualification data to be true and correct.

Declaration for anticipated change in legal structure/ ownership, if any.

The complete annual reports together with Audited statement of accounts of the company for last five years of its own (separate) immediately preceding the date of submission of bid. The Bidder shall also furnish documentary evidence/ declaration regarding Financial restructuring of the company, if any.

If the opening of the bids pursuant to ITB Clause 20.1 or the ascertainment of qualification pursuant to ITB Clause 23.1 is carried out after 30th September(in case of Indian bidder)/16th January (in case of Nepalese bidder), the bidder shall be required to submit the complete annual reports together with Audited statement of accounts of the company for the immediately preceding Financial Year except in cases where the Board of the Company/ Registrar of Companies has granted extension of time for finalization of accounts, for which the bidder has to submit requisite documentary evidence. In case of Bidder's failure to submit the same along with the Bid or subsequently pursuant to ITB Sub-clause 21.1, the Bid shall be rejected.

Bidder shall submit the hard copy & upload the soft/scanned copy of above documents (refer para15.4 below)

However, if the bidder resorts to unethical practices inter-alia including misrepresentation of facts, submission of false and/or forged details/ documents/ declaration as above, the bidder may be debarred from the participation in Purchaser's/SJVN & its subsidiaries tenders for a period of 1 to 3 years, as considered appropriate and its Bid Security/ Contract Performance Guarantee shall be forfeited besides taking other actions as deemed appropriate.

[Note I. In the event the Bidder is not able to furnish the above information of its own (i.e., separate), being a subsidiary company and its accounts are being consolidated with its Group/ Holding/ Parent company, the Bidder should submit the audited balance sheet, income statement, other information pertaining to it only (not of its Group/Holding/Parent company) duly certified by any one of the authority [(i) Statutory Auditor of the Bidder/(ii) Company Secretary of the

Bidder a (iii) A certified Public Accountant] certifying that such

information/documents are based on the audited accounts as the case may be.

Note II. Similarly, if the Bidder happens to be a Group/Holding/ Parent company, the Bidder should submit the above documents/information of its own (i.e., exclusive of its subsidiaries) duly certified by any one of the authority mentioned in Note I above certifying that these information/documents are based on audited accounts, as the case may be.]

Unless otherwise mentioned in **BDS**, bids submitted by a joint venture of two or more firms as partners, if allowed as per stipulated Qualification Requirements in Annexure-A (BDS), shall comply with the following requirements:

- (i) The bid shall include all the information required for Attachment 3 as described above for each joint venture partner.
- (ii) The bid shall be signed so as to be legally binding on all partners.
- (iii) One of the partners responsible for performing a key component of the contract shall be designated as leader; this authorization shall be evidenced by submitting with the bid a power of attorney signed by legally authorized signatories as per Form-10 of Section-VI.
- (iv) The leader shall be authorized to incur liabilities and receive instructions for and on behalf of any and all partners of the joint venture, and the entire execution of the contract, including payment, shall be done exclusively with the leader, provided otherwise requested by the joint venture and agreed between the Purchaser and the leader.
- (v) All partners of the joint venture shall be liable jointly and severally for the execution of the contract in accordance with the contract terms.
- (vi) A copy of the agreement entered into by the joint venture partners shall be submitted with the bid as per Form-11 of Section-VI, including interalia delineation of responsibilities and obligations of each partners appended thereto, notwithstanding the joint and several liability.
- (vii) The joint venture agreement should indicate precisely the responsibility of all members of JV in respect of planning, design, manufacturing and supply. All members of JV should have active participation in execution during the currency of the contract. This should not be varied/modified subsequently without prior approval of the Purchaser; and

In order for a joint venture to qualify, each of its partners or combination of partners must meet the minimum criteria listed in the Qualification Requirement for the Bidder in enclosed **Annexure-A (BDS)** for an

individual Bidder for the component of the contract they are designated to perform. Failure to comply with this requirement will result in rejection of the joint venture bid.

A firm can be a partner in only one joint venture; bids submitted by joint ventures or consortia including the same firm as partner will be rejected.

- (d) Attachment 4: Eligibility and Conformity of the Facilities(Bidder shall submit the hard copy & upload the soft/scanned copy)

Submit the Documentary evidence established in accordance with ITB Clause 3 that the Goods and Related Services offered by the Bidder in its bid or in any alternative bid (if permitted pursuant to ITB Sub-Clause 9.2) are eligible and conform to the Bidding Documents.

The documentary evidence of the eligibility of the Goods and Related Services shall consist of a statement on the country of origin of the Goods and Related Services offered, which shall be confirmed by a certificate of origin issued at the time of shipment.

The documentary evidence of the conformity of the Goods and Related Services to the Bidding Documents may be in the form of literature, drawings and data, and shall furnish:

- (i) a detailed description of the essential technical and performance characteristics of the Goods and Related Services;
 - (ii) a commentary on the Purchaser's Technical Specifications and adequate evidence demonstrating the substantial responsiveness of the facilities to those specifications. Bidders shall note that standards for workmanship, materials and equipment designated by the Purchaser in the Bidding Documents are intended to be descriptive (establishing standards of quality and performance) only and not restrictive. The Bidder may substitute alternative standards, brand names and/or catalog numbers in its bid, provided that it demonstrates to the Purchaser's satisfaction that the substitutions are substantially equivalent or superior to the standards designated in the Technical Specifications.
 - (iii) All details regarding after sale service support offered.
 - (iv) Detailed answers to all the Questions in the Questionnaire, if any, prescribed in the Bidding Document.
 - (v) Details establishing the responsiveness of the offer in accordance with Technical Specification, Volume-II.
- (e) Attachment 5: Subcontractors Proposed by the Bidder
The Bidder shall include in its bid details of all major items of supply or services that it proposes to purchase or sublet, and shall give details of the name and nationality of the proposed Subcontractor, including

vendors, for each of those items. Bidders are free to list more than one Subcontractor against each item of the goods & related services. Their participation should be confirmed with a letter of intent between the parties, as needed, in Attachment 8. Quoted rates and prices will be deemed to apply to whichever Subcontractor is appointed, and no adjustment of the rates and prices will be permitted.

The Bidder shall be responsible for ensuring that any Subcontractor proposed complies with the requirements of ITB Clause 2, and that any goods or services to be provided by the Subcontractor comply with the requirements of ITB Clause 3 and Qualification Requirement for the Bidder, enclosed as Annexure-A (BDS) and Qualification Requirement for subcontractors or Sub-vendors given in Technical Specification, Volume-II.

The Purchaser reserves the right to delete any proposed Subcontractor from the list prior to award of contract, and after discussion between the Purchaser and the Supplier, the corresponding Appendix to the form of Contract Agreement shall be completed, listing the approved Subcontractors for each item concerned.

Bidder shall submit the hard copy & upload the soft/scanned copy of above documents (refer para 15.4 below)

(f) Attachment 5A: (Items, Components, Raw Material, Services proposed to be sourced from Micro and Small Enterprises) - Not Applicable.

(g) Attachment 6: Deviations

In order to facilitate evaluation of bids, deviations, if any, from the terms and conditions or Technical Specifications shall be listed in Attachment 6 to the bid. The Bidder is required to provide the cost of withdrawal for such deviations. However, the attention of the bidders is drawn to the provisions of ITB Sub-Clause 22.3 regarding the rejection of bids that are not substantially responsive to the requirements of the Bidding Documents.

Bidder's attention is also drawn to the provisions of ITB Sub-Clause 22.3.1.

(h) Attachment 7: Alternative Bids

(i) Bid with alternative time schedule is not acceptable.

(ii) Except as provided under subparagraph (iii) below, bidders wishing to offer technical alternatives to the requirements of the Bidding Documents must first price the Purchaser's design of the Goods and Related Services as described in the Bidding Documents, and shall further provide all information necessary for a complete evaluation of the alternatives by the Purchaser, including drawings, design calculations, technical specifications, breakdown of prices, and other

relevant details. Only the technical alternatives, if any, of the lowest evaluated Bidder conforming to the basic technical requirements shall be considered by the Purchaser.

- (iii) When bidders are permitted pursuant to ITB Sub-Clause 9.2 to submit alternative technical solutions for specified parts of the Goods and Related Services, such parts shall be described in Technical Specifications and Drawings. Technical alternatives that comply with the performance and technical criteria specified for the Goods and Related Services shall be considered by the Purchaser on their own merits, pursuant to ITB Sub-Clause 24.2.

- (i) Attachment 8: Manufacturer's Authorisation Form

Bidder shall submit the hard copy & upload the soft/scanned copy of above documents (refer para15.4 below)

- (j) Attachment 9: Work Completion Schedule.

Bidder shall submit the hard copy & upload the soft/scanned copy of above documents (refer para15.4 below)

- (k) Attachment 10: Guarantee Declaration.

Bidder shall submit the hard copy & upload the soft/scanned copy of above documents (refer para15.4 below)

- (l) Attachment 11: Information regarding ex-employees of Purchaser/SAPDC and/or SJVN & its Subsidiaries in Bidder's firm.

- (m) Attachment 12: Price Adjustment Data

- (n) Attachment 13: Declaration regarding Social Accountability

- (o) Attachment 14: Integrity Pact (*submission of Hard Copy in 'Original'*)

The Integrity Pact duly signed on behalf of SAPDC is enclosed at Schedule-F of the Bid Document. The Integrity Pact shall be downloaded, printed and signed by the bidder and the hard copy shall be submitted in Part-I (Envelope-I) as per clause 1.24 of NIT/IFB

Bidder's failure to submit the Integrity Pact duly signed in Original alongwith the Bid or subsequently pursuant to ITB Sub-Clause 21 .1 may lead to rejection of the Bid.

- (p) Attachment 15: Option for Initial Advance (either Interest Bearing Initial Advance or No Initial Advance), and Information for e-payment and PF details. Copy of sample cheque (cancelled) shall also be Submitted (refer ITB clause 15.4).

In this Attachment, the Bidder is required to clearly mention whether the Bidder would opt for Interest Bearing Initial Advance in addition to providing the other information as above.

- (q) Attachment 16: Additional Information (Submit the document, as applicable)
- (i) Certificate from their Banker(s) (as per prescribed formats in Form 12, Section-VI: Sample Forms and Procedures) indicating various fund based/non fund based limits sanctioned to the Bidder and the extent of utilization as on date. Such certificate should have been issued not earlier than three months prior to the date of bid opening. Wherever necessary the Purchaser may make queries with the Bidders' Bankers.
 - (ii) Detailed information on any litigation or arbitration arising out of contracts completed or under execution by it over the last five years. A consistent history of awards involving litigation against the Bidder or any partner of JV may result in rejection of Bid.
 - (iii) Any other information which the Bidder intends to furnish.

Bidder shall submit the hard copy & upload the soft/scanned copy of above documents (refer para 15.4 below)

- (r) Attachment 17: Declaration of Tax exemptions, reductions, allowance or benefits.
- (s) Attachment 18: Declaration
- (t) Attachment 19: Declaration of Key Managerial Person jointly with Power of Attorney holder
- (u) Attachment 20: Unequivocal consent of the proposed Associate(s) for the purpose of executing the „Second Contract“ and/ or „Third Contract“ as an independent Contractor (applicable to Foreign Bidders) - Not applicable

10. Bid Form and Price Schedules

10.1 The Bidder shall complete the Bid Form(s) and the appropriate Price Schedules furnished in the Bidding Documents as indicated therein, following the requirements of ITB Clauses 11 and 12.

11. Bid Prices

11.1 Unless otherwise specified in the Technical Specifications, bidders shall quote for the entire goods and related services on a “single responsibility” basis such that the total bid price covers all the Supplier's obligations mentioned in or to be reasonably inferred from the Bidding Documents in

respect of the design, manufacture, including procurement and subcontracting (if any) and delivery of the goods. This includes all requirements under the Supplier's responsibilities for testing of the goods, where so required by the Bidding Documents, the acquisition of all permits, approvals and licenses, etc. and such other items and services as may be specified in the Bidding Documents, all in accordance with the requirements of the General Conditions of Contract. Items against which no price is entered by the Bidder will not be paid for by the Purchaser when executed and shall be deemed to be covered by the prices for other items.

- 11.2 Bidders are required to quote the price for the commercial, contractual and technical obligations outlined in the Bidding Documents. If a Bidder wishes to make a deviation, such deviation shall be listed in Attachment 6 of its bid. The Bidder is required to provide the cost of withdrawal for such deviations.
- 11.3 Bidders shall give a breakdown of the prices in the manner and detail called for in the Price Schedules. Where no Price Schedules are included in the Bidding Documents, Bidders shall present their prices in the following manner:

Separate numbered Schedules shall be used for each of the following elements. The total amount from each Schedule 1 to 4 shall be summarized in a grand summary of Price Proposal (Schedule 5) giving the total bid price(s) to be entered in the Bid Form.

Schedule 1a Goods to be supplied from abroad (i.e. Outside Nepal) including Type Test Charges for Type Tests to be conducted abroad,

Schedule 1b: Goods to be supplied from within Nepal, including Type Test Charges

Schedule 2 Port handling and Custom clearance of Goods supplied from abroad, if applicable & Local/inland Transportation, In-transit insurance and loading.

Schedule 3 Supervision of Installation Services
(NOT APPLICABLE)

Schedule 4 Taxes and Duties included in Schedule 1 to 3

Schedule 5 Grand Summary (Schedule Nos. 1 to 3)

Schedule 6a: Break-up of Type Test Charges for Type Tests to be conducted abroad (NOT APPLICABLE)

Schedule 6b: Break-up of Type Test Charges for Type Tests to be

conducted in India (NOT APPLICABLE)

- 11.3.1 The bid price for the items for which quantities have been estimated by the Purchaser shall be governed based on the unit price quoted by the bidder.
- 11.3.2 Deleted.
- 11.3.3 It shall be the responsibility of the bidders to pay all statutory taxes, duties and levies and interest, if applicable on account of additional revised invoice issued for actual material supplied, to the concerned authorities for such return/ supply of surplus material, which would otherwise have been, lawfully payable. The bidders shall submit an indemnity bond to keep Purchaser harmless from any liability, before release of such material to the bidder by Purchaser.
- 11.3.4 Set/Lot/Lumpsum shall be governed as per the requirement of the corresponding item description read in conjunction with relevant provisions of Technical Specifications.
- 11.4 In the schedules, Bidder shall give the required details and a breakdown of their price as follows:

- (a) Goods to be supplied from abroad (i.e. outside Nepal) by a Foreign Bidder shall be quoted on CIP Entry Border Point basis in Schedule 1a.

Type Test Charges, if any, to be conducted abroad (i.e. outside Nepal) shall also be quoted in Schedule 1a.

The Contractor shall be responsible and be liable for payment of Customs duty/Bhansar/Other Taxes & Duties as applicable on CIP Entry Border Point component of the Goods to be supplied from abroad. However, the Purchaser, as an importer, shall furnish promptly necessary clarifications and documents as may be required to be furnished by the importer for the purpose of customs clearance. The Customs duty/Bhansar/Other Taxes & Duties, included in Bid Prices, as applicable shall be indicated separately in Schedule 4.

The Price quoted in respect of these supplies shall be including Taxes & Duties, if any.

- (b) Goods to be supplied from within Nepal, shall be quoted on an EXW (ex-factory, ex-works, ex-warehouse or off-the-self, as applicable) basis and Type Test Charges for Type Test to be conducted in Nepal, shall also be quoted in Schedule 1b.

The EXW price shall be inclusive of all cost as well as duties and taxes (viz., customs duties & levies, other taxes and duties as applicable etc.) paid or payable on components, raw materials and any other items used

for their consumption incorporated or to be incorporated in the Goods.

Further, in case of imported Equipment/items offered as “Off the Shelf” or dispatched directly, the price of such Goods shall be inclusive of all cost as well as any duties paid/payable in relation to import of such goods (viz., Customs duties & levies, other taxes and duties as applicable etc.).

The Price quoted in respect of these supplies shall be including Taxes & Duties, if any.

- (c) Local/Inland transportation, In-transit insurance, loading and unloading of the Goods to be supplied shall be quoted separately in Schedule 2. Further, charges for Custom clearance & handling for CIP Entry Border Point supply of Goods from abroad, if any, shall also be quoted in Schedule 2.

The Price quoted in respect of these services shall be including Taxes & Duties, if any.

- (d) Rate of Customs duty/Bhansar and Other Taxes & Duties, included in Bid Prices, as applicable on Supply of goods shall be indicated in Schedule - 4.
- (e) The Bidder shall include In-transit insurance charges in its bid prices as per insurance requirement mentioned in Section – IV: General Conditions of Contract (GCC) and Appendix-3: Insurance Requirements to Form of Contract Agreement as contained in Section VI: Sample Forms and Procedures (FORMS) of the Bidding Documents.
- (f) The bidder shall fill up Schedule 1 to 5. Bidder shall not carry out any modification or changes in the respective work sheets of Schedule-5 (Grand Summary) and Bid Form.

The bidder shall fill as per the ITB Clause 9. II of Schedule 1 to 5 and Bid Form

Rates should be filled in both figures and words. In case of ambiguities in between the rate in figures and the rate in words, the rate quoted in words shall prevail and the amount shall be corrected accordingly. The SAPDC reserves the right to adjust arithmetical or other errors in any tender/quotation in the way which it considers suitable.

- (h) If any Goods required to complete the facilities, is manufactured outside the Purchaser’s Country, the Contractor shall be entirely responsible for all taxes, stamp duties, license fees, and other such levies imposed outside the Purchaser’s Country.

In such case, Customs duties/ Bhansar on the Goods covered in the Contract to be imported into Nepal against Purchaser's Import License and which will become the property of the Purchaser under the Contract, shall be to the contractor's account and shall be paid directly by the Contractor to Government of Nepal or concerned authorities.

- (i) **In terms of Project Development Agreement signed between Government of Nepal (GoN) and Purchaser on 24.11.2014**, the GoN shall exempt import of cement, iron and steel products from payment of Customs Duty/Bhansar, subject to compliance of norms of Investment Board of Nepal (IBN). The amount of exemption shall be limited to 50% of the rate of custom duty prevailing as on the date of PDA or the actual rate of Custom Duty/Bhansar, whichever is lower. The Contractor shall take all steps necessary for obtaining the above exemption and coordinate with concerned authorities of GoN. The Purchaser shall not be liable if Contractor fails to obtain such exemptions from GoN.
- (j) In addition to above, bidders are requested to consider exemptions as per **Hydro Development Policy of Nepal 2001** which is available at www.doed.gov.np.
- (k) Bidders may like to ascertain availability of exemptions, reductions, allowances or benefits in case of goods and services to be supplied to the Purchaser. They shall solely be responsible for obtaining such benefits, and in case of failure to receive such benefits for any reasons whatsoever, the Purchaser will not compensate the Bidder. The Bidder shall furnish along with their bid, a declaration to this effect in Attachment 17 as per the format enclosed in the Bidding Documents.

Further, if issuance of the necessary certificate for availing such exemptions, reductions, allowances or benefits is permitted and is required to be issued by the Purchaser in line with the relevant policies, rules and procedures of Govt. of Nepal in vogue, the same shall be considered for issuance by the Purchaser, provided the Bidder explicitly indicates in their bid that they have quoted prices after considering the applicable concessional duty/exemption. However, the Bidder alone shall be responsible for obtaining any benefits there from as may be admissible under Govt. policies/procedures and in case of their failure to receive such benefits, partly or fully, for any reason whatsoever, the Purchaser will neither be responsible nor be liable to compensate the Contractor, and the Purchaser shall have no financial liability on this account.

Where the Bidder has quoted taking into account such benefits, he must give all information required for issuance of such certificate in terms of the relevant notifications of the Govt. of Nepal along with his bid in Attachment 17. In case bidder has not indicated such information or has indicated "to be furnished later on" in Attachment 17, the same shall be

construed to mean that no benefit has been passed on by the bidder to the Purchaser, and the Purchaser shall not issue any certificate to the contractor for availing the same even if admissible.

- (l) Purchaser shall, deduct taxes at source as per the applicable laws/rules, if any, and issue Tax Deduction at Source (TDS) Certificate to the Contractor.
- (m) Foreign Bidders to ensure PAN/VAT/company registration of their firm in Nepal as per prevailing acts in Nepal after award of work (if applicable).
- (n) For the purpose of Evaluation, Total Bid Prices, which are inclusive of Taxes and Duties, quoted by Bidder shall be considered.
- (o) In addition to Taxes and Duties mentioned above, if any other Taxes and Duties are applicable then it shall be to the Bidder's/Contractor's account. Purchaser shall bear no responsibility/liability on account of any Taxes and Duties.

11.4.1 Deleted

11.4.2 The terms EXW, CIF etc., shall be governed by the rules prescribed in the current edition of Incoterms, published by the International Chamber of Commerce, 38 Cours Albert 1er, 75008 Paris, France.

11.5 The prices shall be in accordance with the following:

Adjustable Price: Prices quoted by the Bidder shall be subject to adjustment during performance of the contract to reflect changes in the cost elements such as labor, material, etc. in accordance with the procedures specified in the corresponding Appendix – 2 to the Form of Contract Agreement. A bid submitted with a fixed price quotation will not be rejected, but the price adjustment will be treated as zero. The price adjustment provision will not be taken into consideration in bid evaluation. Bidders are required to indicate the source of labour & materials indices in Attachment 12.

11.6 Price bid Under Envelope-II shall be submitted only through SJVN e-portal i.e <https://sjvn.nic.in> (by filling price part in electronic form/template & uploading soft/scanned copy of Dully filled, Signed & stamped of bid form & Schedules under Envelope-II) (Not in Hard copy), any other mode of submission of price bid part shall not be accepted.

12. Bid Currencies

12.1 Prices shall be quoted in Indian/ Nepalese Rupees Only.

I. Prices shall be quoted in Indian Rupees (INR) for the following:

- a. Goods to be supplied from abroad (i.e. from outside Nepal) as per Schedule 1a.

II. Prices shall be quoted in Indian/ Nepalese Rupees for the following:

- b. Goods to be supplied from within Nepal quoted as per Schedule 1b.
c. Local/Inland transportation, In-transit insurance, loading and unloading of the Goods to be supplied as per Schedule 2.

However, payments to the Foreign Bidder in INR (for Goods to be supplied from abroad) shall be based on Bills Clearing (B.C.) Selling Market Rate of Exchange (MRE) established by State Bank of India (SBI), India prevailing on dates as indicated in Appendix-1(TERMS AND PROCEDURES OF PAYMENT). In case payment is made in INR, all charges including wire charges towards Foreign exchange conversion shall be borne by the Foreign Bidder/Contractor.

13. Bid Security

- 13.1 The Bidder shall furnish, as part of its bid, a bid security in the amount and currency as stipulated in the NIT/IFB/ **BDS & as below**. The bid security must be submitted in the form provided in the Bidding Documents/ **as below**.

NPR 2,59,20,000/- only (For bidders who choose to submit the EMD in NPR) or INR 1,62,00,000/- shall be required to be submitted with the proposal (In Envelope- I i.e Along with Technical bid) in either of the form:

- i. Bank Guarantee in favor of SJVN Arun-3 Power Development Company Pvt. Ltd. from any "A" class Bank in Nepal for the amounts expressed in Nepalese Rupees (NPR). The Bank Guarantees in equivalent INR amount shall be acceptable only if these are issued by a Scheduled Bank of India duly counter guaranteed by any A class bank in Nepal.

Bank Guarantee for EMD **in original** shall be submitted along with the proposal. Bank Guarantee shall be in the format provided in tender document (Section-VI, Volume-I, Sample forms and Procedures). EMD shall remain valid for a period of 30 days beyond the original validity period of the bid/proposal (i.e 210 days from the last date of submission of bid) or beyond any period of extension subsequently requested under ITB Clause 14.2.

or

- ii. FDR **in original** (issued by a "A" Class Nepalese Bank/Scheduled Bank of India shall only be acceptable) duly pledged in favour of SJVN Arun-3 Power Development Company Pvt. Ltd.

or

- iii. Manager's cheque **in original** (issued by a "A" Class Nepalese Bank shall only be acceptable) in favour of SJVN Arun-3 Power Development Company Pvt. Ltd. payable at Khandbari.

or

- iv. Alternatively, payment against EMD may also be made directly in the following account of SJVN Arun-3 Power Development Company Pvt. Ltd. However, proof

of same shall be submitted by the Firm/agency with the Proposal in Part-I (Envelope-I):

NPR Account Details:

Everest Bank Limited

Name: SJVN Arun-3 Power Development Company Pvt. Ltd.

Acc. No. 00800105200477

Swift Code: EVBLNPKA

Bidders are advised and shall be responsible to ensure the receipt of net amount (excluding bank transfer charges) in above account before last date of submission of bids.

Any bid not accompanied by an acceptable Earnest Money Deposit shall be rejected by SAPDC as non-responsive.

However, if Bidder/Firm opt for submission of Earnest Money Deposited (EMD)/Bid Security directly in the bank account of SAPDC, then the documentary evidence/ proof of same (swift statement/ transfer statement/ account statement) has to be submitted along with technical bid in Part-I(Envelope-I)

Note: For conversion the currency, (1 INR (Indian Rupees) = 1.6 NPR (Nepalese Rupees) and vice versa shall be considered.

- 13.2 The format of the bank guarantee(Section-VI, Volume-I, Sample forms and Procedures) towards bid security as per 1.2.5 of NIT/IFB shall be in accordance with the form of bid security included in the Bidding Documents & valid 30 days beyond the original validity period of the bid/proposal (i.e 210 days from the last date of submission of bid) or beyond any period of extension subsequently requested under ITB Clause 14.2.
- 13.3 Any bid not accompanied by an acceptable bid security, except as exempted at 13.1 above, shall be rejected by the Purchaser as being nonresponsive, pursuant to ITB Sub-Clause 22.4. The bid security of a joint venture must be in the name of all the partners in the joint venture submitting the bid.
- 13.4 The bid securities of unsuccessful bidders will be returned as promptly as possible, but not later than twenty-eight (28) days after the expiration of the bid validity period.
- 13.5 The successful Bidder shall be required to keep its bid security valid for a sufficient period till the performance security(ies) pursuant to ITB Clause 35 are furnished to the satisfaction of the Purchaser. The bid security of the successful Bidder will be returned when the Bidder has signed the Contract Agreement, pursuant to ITB Clause 34, and has furnished the required performance security, pursuant to ITB Clause 35.

13.6 The bid security may be forfeited

- (a) if the Bidder withdraws its bid during the period of bid validity specified by the Bidder in the Bid Form/bid document; or
- (b) In case the Bidder does not withdraw the deviations proposed by him, if any, at the cost of withdrawal stated by him in the bid and/or accept the withdrawals/rectifications pursuant to the declaration/confirmation made by him in Attachment –
Declaration of the Bid; or
- (c) If a Bidder does not accept the corrections to arithmetical errors identified during preliminary evaluation of his bid pursuant to ITB Sub-Clause 27.2/9.II; or
- (d) If, as per the requirement of Qualification Requirements the Bidder is required to submit a Deed of Joint Undertaking and he fails to submit the same, duly attested by Notary Public of the place(s) of the respective executant(s) or registered with the Indian Embassy/High Commission in that Country, within ten days from the date of intimation of post – bid discussion; or
- (e) in the case of a successful Bidder, if the Bidder fails within the specified time limit
 - (i) to sign the Contract Agreement, in accordance with ITB Clause 34, or
 - (ii) to furnish the required performance security, in accordance with ITB Clause 35 and/or to keep the bid security valid as per the requirement of ITB Sub-Clause 13.5.

13.7 No interest shall be payable by the Purchaser on the above Bid Security.

14. Period of Validity of Bid

- 14.1 Bids shall remain valid for the period of six months(180 days) after the date of opening of Techno – Commercial Part i.e. First Envelope, prescribed by the Purchaser, pursuant to ITB Sub-Clause 20.1. A bid valid for a shorter period shall be rejected by the Purchaser as being non- responsive.
- 14.2 In exceptional circumstance, the Purchaser may solicit the Bidder's consent to an extension of the bid validity period. The request and responses thereto shall be made in writing or by cable. If a Bidder accepts to prolong the period of validity, the bid security shall also be suitably extended. A Bidder may refuse the request without forfeiting its bid security. A Bidder granting the request will not be required or permitted to modify its bid.

15. Format and Signing of Bid

15.1 The bidder shall prepare the bid in the manner indicated in ITB Clause 9.0 and submit the bid in following manner.

- a. The bid shall be signed by a person duly authorized to sign on behalf of the Bidder, pursuant to ITB Clause 15.5. Each and every page of the documents submitted in the bid shall also be signed by usual signature of the person duly authorized pursuant to Clause ITB Clause 15.5.
- b. The bid should be serially numbered and properly indexed mentioning all constituents of bid including any enclosures/attachments etc. and their location page numbers in the bid. Failure to submit the bid in systematic manner as above may result oversight of any important information provided by the bidder for which SAPDC shall not be responsible.
- c. The Bid shall contain no overwriting, alterations, omissions, or additions, unless such corrections are initiated by the person(s) signing the Bid. Corrections if any shall only be made by scoring out the cancelled portion, writing the correction, initiating and dating it by the person(s) signing the Bid.
- d. All witnesses and sureties shall be persons of status and their full names, occupations and addresses shall be stated below their signatures.
- e. **The bidder shall not give any indication about the bid price in any manner whatsoever in the “Techno-Commercial” part of the bid. Non-compliance of this provision shall result in the rejection of bid.**

First Envelope(Envelope-I):

- (i) The bid consisting of the documents listed in ITB Clause 9 including relevant documents (refer ITB Clause 15.4) & Form of the bid for First Envelope (Techno-Commercial), as per tender document, shall be duly filled, signed and stamped shall be submitted in hard copy and upload the soft copy/scanned of the same on e-portal.

Submission of any documents by any other means(i.e other than this) shall not be accepted by the Purchaser in any circumstances.

(ii) Followings document:

- a) Manager’s cheque (In original) Tender document cost/ Bidding Document fee of the amount as specified in the in accordance with clause 5.4 of ITB/ clause 1.2.4 of NIT/IFB or proof of same in case of online Bank Transfer
- b) Bid Security (BG in Original/proof of same in case of online Bank Transfer) in accordance with clause 1.2.5 of NIT/IFB, in separate envelope in accordance with clause 13 of ITB, Section-II
- c) Integrity Pact(Schedule-F) (in Original) in accordance with clause 9.3 (o) of ITB, Section-II

The Integrity Pact duly signed on behalf of SAPDC is enclosed at Schedule-F of the Bid Document. The Integrity Pact shall be downloaded, printed and signed by the bidder and the hard copy shall be submitted in Part-I (Envelope-I).

- d) Power of Attorney as per Clause 9.3 (b).
- e) In case of Bid from Joint Venture, the Joint Venture Agreement & Power of Attorney of Joint Venture Agreement, both in original
- f) Any other document further specified in the BDS duly signed and stamped on each page.
- g) All the document, Attachments (Attachment & Bid Form(Ref Volume-III, Section-I) (First Envelope) including attachment to QR) as specified under the Clause 9, 9.1, 9.2, 9.3 of ITB & all the documents mentioned at 15.4 of ITB and as per manner stipulated at clause 16 of ITB under Heading Submission of Bids.

Second Envelope(Envelope-II):

- (i) Price Schedules (Price - Part) covering details regarding summary of price details & Bid Forms(Ref Volume-III, Section-II) & its revision covering various price schedules and bid forms for Second Envelope.

Price bid Under Envelope-II shall be submitted only through SJVN e-portal i.e <https://sjvn.nic.in> (by filling price part in electronic form/template & uploading soft/scanned copy of Dully filled, Signed & stamped of bid form & Schedules under Envelope-II) (Not in Hard copy), any other mode of submission of price bid part shall not be accepted.

Rates should be filled in both figures and words. In case of ambiguities in between the rate in figures and the rate in words, the rate quoted in words shall prevail and the amount shall be corrected accordingly. The SAPDC reserves the right to adjust arithmetical or other errors in any tender/quotation in the way which it considers suitable.

Bidders to note that notwithstanding the prices quoted by the bidder in this form, the Purchaser reserve the right to correct the prices for purpose of evaluation and award in accordance with the provisions of bidding documents.

Submission of the price schedules as per ITB Clause 11/ 9. II to be submitted only through SJVN e-portal i.e <https://sjvn.nic.in> (by filling price part in electronic form/template & uploading soft/scanned copy of Dully filled, Signed & stamped of bid form & Schedules under Envelope-II). Submission by any other means shall not be accepted by the Purchaser in any circumstances.

- 15.2 The bid shall contain no alterations, omissions or additions, unless such corrections are initialed by the person or persons signing the bid.
- 15.3 The Bidder shall furnish information as described in the last paragraph of the Bid Form on commissions or gratuities, if any, paid or to be paid to agents relating to this bid, and to contract execution if the Bidder is awarded the contract.
- 15.4 The List of following documents shall be submitted as per table given below

| S. No. | Description of Documents | Name of file to be uploaded on portal |
|--------|---|---------------------------------------|
| 1. | Power of Attorney | Pdf |
| 2. | Manager cheque(In original) / documentary evidence in case online payment against Bidding Document fee & BG/FDR/ Manager cheque (in original)/ documentary evidence in case online payment against EMD/Bid security | Pdf |
| 3. | Constitution of legal status | Pdf |
| 4. | Declaration for anticipated change in legal structure/ownership | Pdf |
| 5. | The principal place of business | Pdf |
| 6. | The place of Incorporation or the place of registration and the nationality of the owner | Pdf |
| 7. | Technical Experience certificate issued by utility | Pdf |
| 8. | Financial Balance Sheets (for last five years) | Pdf |
| 9. | Declaration in regard to Financial re-structuring(if any) | Pdf |
| 10. | Technical GTP | Pdf |
| 11. | Type Test Report | Pdf |
| 12. | Bank Certificate | Pdf |
| 13. | Manufacturer Authorization | Pdf |
| 14. | Work Schedule (BAR Chart) | Pdf |
| 15. | Guarantee Declaration | Pdf |
| 16. | Documentary Evidence for Base Price Indices | Pdf |
| 17. | Cancelled Cheque | Pdf |
| 18. | if Bidder/Firm opt for submission of Bid document fee/Tender document cost directly in the bank | Pdf |

| | | |
|-----|---|-----|
| | account of SAPDC, then the documentary evidence/ proof of same (swift statement/ transfer statement/ account statement) has to be submitted along with technical bid in Part-I(Envelope-I) | |
| 19. | if Bidder/Firm opt for submission of Earnest Money Deposited (EMD)/Bid Security directly in the bank account of SAPDC, then the documentary evidence/ proof of same (swift statement/ transfer statement/ account statement) has to be submitted along with technical bid in Part-I(Envelope-I) | Pdf |
| 20. | Joint Undertaking by the Licensor along with the Bidder (in Original), if applicable, duly signed and stamped on each page. | Pdf |
| 21 | Dully filed signed & stamped Integrity Pact(Schedule-F) | Pdf |
| 22. | Other Documents | Pdf |

15.5 Authorization

The Bidder shall provide, with the Bid, a written Authorization, indicating that the person(s) signing the bid has(ve) legal authority to sign and submit the Bid and that the bid is binding upon the Bidder during the full period of its validity as per ITB clause 9.3(b). and shall be in accordance with following:

- a. Sole proprietor Firm: In case the bidder is a Sole Proprietor Firm, the bidder shall submit Self-declaration /certificate declaring that his/her Concern is a Proprietary Concern and he/she is sole proprietor of the Concern along with PAN in the proprietor name.
- b. Partnership Firm: In case the bidder is a partnership firm, the bidder shall submit a Power of Attorney duly authorizing one or more of the partners of the firm or any other person (s), authorized by all the partners to act on behalf of the firm and to submit & sign the tender, sign the Agreement.
- c. Other than Sole Proprietor/Partnership Firm: In case the nature of the Bidder is other than Sole Proprietor/Partnership Firm, the bidder shall submit duly notarized power of attorney in favour of person authorized to sign and submit the bid along with supporting documents such as board or shareholders resolution/power of attorney in favour of the person executing the power of attorney in favour of person authorized to sign and submit the bid, as required.

15.6 **The bidder shall not give any indication about the bid price in any manner whatsoever in the “Techno-Commercial” part of the bid. Non-compliance of this provision shall result in the rejection of bid.**

15.7 The bidder shall not take any deviation from the bid conditions

D. Submission of Bids:

16.1 Sealing and Marking and submission of Bids

- a. The Bidder shall submit hard copy of the technical bid under sealed envelope also upload the soft/scanned copy of same on SJVN e-Portal as per the provisions of tender document (refer para 15.1 & 15.4 above & ITB Clause 9.3), submit the Bidding Document fee (as per provision IFB/ITB/BDS of tender document) or documentary evidence in support of exemption of Document fee (as applicable), Bid Security (as per provision IFB/ITB/BDS of tender document) or documentary evidence in support of exemption of Bid Security (as applicable), Integrity Pact, Power of Attorney, Joint Venture Agreement (as applicable) and Power of Attorney of Joint Venture Agreement (as applicable), Joint Deed of Undertaking (as applicable) and any other documents as required (refer para 15.1 above) & (Ref Volume-III, Section-I), duly marked First Envelope (Techno – Commercial Part) & Sealed. Further, the bid submitted by the bidder is found different from the document uploaded by SAPDC & downloaded by bidder from the website, as part of the bidding document or tampered/modified contents, the bidder may run with risk of rejection of bid.
- b. The envelope containing hard copy of documents shall;
- be addressed to the Employer at the address provided in the NIT/IFB;
 - bear the name and identification number of the contract as defined in the NIT/IFB; and
 - provide a warning not to open before the time and date for bid opening, as specified in the NIT/IFB.
 - In addition to the identification required above, the envelopes shall indicate the name and address of the Bidder to enable the bid to be returned unopened in case it is declared "Late Bid" pursuant to ITB Clause 18.
 - If the envelope(s) are not sealed and marked as above, the Employer will assume no responsibility for the misplacement.
- 16.2 The Sealed envelope shall
- be addressed to the Purchaser at the address given in the **NIT/IFB**, and
 - bear the contract name indicated in the **NIT/IFB**, the Invitation for Bids title and number indicated in the NIT/IFB/BDS, and the statement "Do Not Open Before [date]," to be completed with the time and date specified in the **NIT/IFB**, pursuant to ITB Sub-Clause 20.1.
- 16.3 Bidding Document cost, Power of Attorney, Bid Securities and Integrity Pact in original shall be submitted in separate superscribed envelopes alongwith First Envelope.

Bidder may submit other documents which they consider relevant along with First Envelope.

All the envelopes shall also indicate the name and address of the Bidder so that the same can be returned unopened in case it is declared "late."

- 16.4 If the envelopes are not sealed and marked as required by ITB Sub- Clause 16.1 & 16.2 above, the Purchaser will assume no responsibility for the bid's misplacement or premature opening.
- 16.5 Price Schedules (Price - Part) covering details regarding summary of price details & Bid Forms(Ref Volume-III, Section-II) & its revision covering various price schedules and bid forms for Second Envelope.
- Price bid Under Envelope-II shall be submitted only through SJVN e-portal i.e <https://sjvn.nic.in> (by filling price part in electronic form/template & uploading soft/scanned copy of Dully filled, Signed & stamped of bid form & Schedules under Envelope-II) (Not in Hard copy), any other mode of submission of price bid part shall not be accepted.

17. **Deadline for Submission of Bids**

- 17.1 Complete Bid (Hard copy part & soft part by uploading on SJVN e-Portal) must be submitted and must be received by the Employer at the address of NIT/IFB/BDS or before the submission time and date as stipulated in the bidding document (NIT/IFB/BDS). In the event of the specified date for the submission of bids being declared a holiday for the Employer, the bid will be received up to the specified time on the next working day.
- 17.2 The Purchaser may, at its discretion, extend this deadline for submission of bids any time prior to opening of bids by issuing an Addendum, in which case all rights and obligations of Purchaser and bidders will thereafter be subject to the deadline as extended.

Further the Purchaser also reserves the right to extend bid submission timeline or recall if e-procurement server(i.e SJVN e-portal) is down(i.e inaccessible/inoperative) the tender for a prolonged period of time within the last 24 hours of the bid submission due date.

17.2.1 Deleted

18. **Late Bids**

- 18.1 The bidder shall not be permitted to submit the Soft Copy Part of the bid after the deadline for submission prescribed by the Purchaser in the NIT/IFB/BDS. The e-Procurement system would not allow any late submission of bids through the portal after due date & time as specified.

Hard Copy (i.e Technical bid part under envelope-I):Sealed bid must be submitted at the address & time given in NIT/IFB. SAPDC shall not be responsible for any postal delay in respect of submission of the bid.

In case Hard copy part of the bid i.e Technical bid Under 1st Envelope-I is not received till the deadline for submission of the same prescribed by the Purchaser, but the bidder has uploaded the soft/scanned copy of the technical bid, the soft copy of bid under first envelope. The uploaded technical bid on the portal shall be opened and such bids may be rejected during preliminary examination.

The bid is received by the Purchaser after the deadline for submission prescribed by the Purchaser in the NIT/IFB/BDS, the bid will be considered as late bid. In such a case, the bids will be rejected.

19. Modification and Withdrawal of Bids

- 19.1 Bidder may modify its bids through the relevant provisions on the document. The Bidder may modify or withdraw its bid after submission, provided that modification is done on the portal as well as notice is received by the Purchaser prior to the deadline prescribed for bid submission.
- 19.2 The Bidder's modifications shall be done and submitted as follows:
- (i) Modified Electronic form of the bid as per the provision of portal therein.
 - (ii) Soft copy of the entire bid if any modification is there.
- 19.3 Bidder may withdraw its bid through the relevant provisions of tender document/portal only.
- 19.4 No bid may be withdrawn in the interval between the bid submission deadline and the expiration of the bid validity period specified in ITB Clause 14. Withdrawal of a bid during this interval may result in the Bidder's forfeiture of its bid security, pursuant to ITB Sub-Clause 13.6.

E. Bid Opening and Evaluation

20. Opening of First Envelope by Purchaser

- 20.1 The Purchaser will open the First Envelope i.e. Techno – Commercial Part in public, including withdrawals and modifications made pursuant to ITB Clause 19, in the presence of bidders' designated representatives who choose to attend, at the time, date, and location stipulated in the NIT/IFB/BDS. The bidders' representatives who are present shall sign a register evidencing their attendance. In the event of the specified date for the submission of bids being declared a holiday for the Purchaser, the bids will be received upto the appointed time on the next working day.
- 20.2 During the opening of bids, Envelopes marked "Withdrawal" shall be opened first. Bids for which an acceptable notice of withdrawal has been submitted pursuant to ITB Clause 19.1 shall be not be opened.
- 20.3 For all other Bids, the bidders' names, deviation having cost of withdrawal, if any, the presence of bid security, Integrity Pact and any such other details as the Purchaser may consider appropriate, will be get declared through the portal by the Purchaser. Subsequently, all envelopes marked "Modification"

shall be opened.

Opening of bid, whether or not accompanied with the Tender fee and/or bid security, shall not be construed to imply its acceptability which shall be examined in detail pursuant to the provisions contained in this Section-II.

The bids whose Tender fee and/or bid security is either deficient in value and/or form, will be rejected out rightly & will not be evaluated further.

If Manager's cheque against Tender fee & BG against Bid security not submitted in original in Envelope-I then the will be rejected out rightly & will not be evaluated further.

20.4 Deleted

20.5 Bids not opened at bid opening shall not be considered further for evaluation, irrespective of the circumstances.

21. Clarification of Bids

During bid evaluation, the Purchaser may, at its discretion, ask the Bidder for a clarification of its bid. In case of erroneous/non submission of documents related to/identified in ITB Sub-Clause 9.3 (b), (o), (s), (t),(u), (v)and (w) or Deed of Joint Undertaking, pursuant to ITB Sub-Clause 9.3 (c) & (e), the complete annual reports together with Audited statement of accounts pursuant to ITB Sub-Clause 9.3 (c), Documentary evidence in case of SAPDC bank transfer towards the cost of Bidding Documents & Bid security as per bid condition, required to be submitted by the Bidder as per the provisions of the Bidding Documents, the Purchaser may give the Bidder not more than 7 working days notice to rectify/furnish such documents, failing which the bid shall be rejected. The request for clarification and the response shall be in writing/email, and no change in the price or substance of the bid shall be sought, offered or permitted.

In case of non-submission of documents related to/identified in Attachment-11 {"Information regarding ex-employees of Purchaser in Bidder's firm"}, the Purchaser may give the Bidder not more than 7 working days notice to rectify/furnish such documents, failing which Purchaser reserves the right to reject such bids. Purchaser shall be sole judge in this regard..

22. Preliminary Examination of First Envelope

22.1 The Purchaser will examine the bids to determine whether they are complete, whether required sureties have been furnished, whether the documents have been properly signed, and whether the bids are generally in order.

In case of non-submission of bid in the portal (soft copy part of the bid) within the stipulated deadline, then even if the bidder has submitted the specific

documents in hard copy part in original within the stipulated deadline pursuant to ITB 17.1, its bid shall be considered as incomplete bid, which shall be summarily rejected.

Similarly, in case of non-submission of Hard copy part of the bid, but the bidder has uploaded the soft copy part of the bid, the bid will be considered as incomplete bid. In such a case, the soft copy part of the first envelope bid uploaded on the portal shall be opened. Such bids may be rejected during preliminary examination.

- 22.2 The Purchaser may waive any minor informality, nonconformity or irregularity in a bid that does not constitute a material deviation, whether or not identified by the Bidder in Attachment 6 to its bid, and that does not prejudice or affect the relative ranking of any Bidder as a result of the technical and commercial evaluation, pursuant to ITB Clause 24.
- 22.3 Prior to the detailed evaluation, the Purchaser will determine whether each bid is of acceptable quality, is complete and is substantially responsive to the Bidding Documents. Any deviations, conditionality or reservation introduced in Attachment-6 and/or in the Bid Form, Technical Data Sheets and covering letter, or in any other part of the bid will be reviewed to conduct a determination of the substantial responsiveness of the bidder's bid. For purposes of this determination, a substantially responsive bid is one that conforms to all the terms, conditions and specifications of the Bidding Documents without material deviations, objections, conditionalities or reservations. A material deviation, objection, conditionality or reservation is one (i) that affects in any substantial way the scope, quality or performance of the contract; (ii) that limits in any substantial way, inconsistent with the Bidding Documents, the Purchaser's rights or the successful Bidder's obligations under the contract; or (iii) whose rectification would unfairly affect the competitive position of other bidders who are presenting substantially responsive bids.
- 22.3.1 Bids containing deviations from critical provisions relating to GCC Clauses 2.14 (Governing Law), 8 (Terms of Payment), 9.3 (Performance Security), 10 (Taxes and duties), 21.2 (Completion Time Guarantee), 22 (Defect Liability), 24 (Patent Indemnity), 25 (Limitation of Liability), 35 (Settlement of Disputes), 36 (Arbitration) and Appendix 2 to the Form of Contract Agreement (Price Adjustment) will be considered as non-responsive.
- 22.3.2 Regarding deviations, conditionality or reservations introduced in the bid, which will be reviewed to conduct a determination of substantial responsiveness of the Bidder's bid as stated in ITB Sub- Clause 22.3, the order of precedence of these documents to address contradictions, if any, in the contents of the bid, shall be as follows:
- I. Bid Form.

- II. Attachment-6 : Deviations
- III. Technical Data Sheet
- IV. Any other part of the bid

Contents of the document at Sr. No. I above will have overriding precedence over other documents (Sr. No. II to IV above). Similarly, contents of document at Sr. No. II above will have overriding precedence over other documents (Sr. No. III to IV above), and so on.

- 22.4 If a bid is not substantially responsive, it will be rejected by the Purchaser, and may not subsequently be made responsive by the Bidder by correction of the nonconformity. The Purchaser's determination of a bid's responsiveness is to be based on the contents of the bid itself without recourse to extrinsic evidence.

23. Qualification

- 23.1 The Purchaser will ascertain to its satisfaction whether Bidders determined having submitted substantially responsive bids are qualified, as per the Qualification Requirement specified in Annexure – A (BDS) to satisfactorily perform the contract. The Purchaser shall be the sole judge in this regard and the Purchaser's interpretation of the Qualification Requirement shall be final and binding.
- 23.2 The determination will take into account the Bidder's financial, technical capabilities including production capabilities, in particular the Bidder's contract work in hand, future commitments and current litigation and past performance. It will be based upon an examination of the documentary evidence of the Bidder's qualifications submitted by the Bidder in Attachment 3 to the bid, as well as such other information as the Purchaser deems necessary and appropriate. This shall, however, be subject to assessment that may be carried out, if required, by the Purchaser as per the provisions of Annexure -A (BDS). The Purchaser shall be the sole judge in this regard.
- 23.3 The Purchaser may waive any minor informality, nonconformity or irregularity in a bid that does not constitute a material deviation, affecting the capability of the Bidder to perform the Contract.
- 23.4 An affirmative determination will be a prerequisite for the Purchaser to evaluate the Techno – Commercial Part and open the Second Envelope of the Bidder. A negative determination will result in rejection of the Bidder's bid.

24. Evaluation of Techno-Commercial Part (First Envelope)

- 24.1 The Purchaser will carry out a detailed evaluation of the bids of the qualified bidders in order to determine whether the technical aspects are in accordance with the requirements set forth in the Bidding Documents. In order to reach such a determination, the Purchaser will examine the information supplied by the bidders, pursuant to ITB Clause 9, and other requirements in the Bidding Documents, taking into account the following factors:

- (a) overall completeness and compliance with the Technical Specifications and Drawings; deviations from the Technical Specifications as identified

in Attachment 6 to the bid and those deviations not so identified; suitability of the facilities offered in relation to the environmental and climatic conditions prevailing at the site; and quality, function and operation of any process control concept included in the bid. The bid that does not meet minimum acceptable standards of completeness, consistency and detail will be rejected for non-responsiveness.

- (b) achievement of specified performance criteria by the goods and related services
- (c) compliance with the time schedule called for in the corresponding Appendix to the Form of Contract Agreement and evidenced as needed in a milestone schedule provided in the bid;

Time schedule (program of performance)

The delivery of Goods and Related Services covered by this bidding shall have the „Taking Over“ by the Purchaser after successful Completion within the period specified in **BDS**. Bidders are required to base their prices on the time schedule given in Appendix 4 to the Form of Contract Agreement (Time Schedule) or, where no time schedule is given in Appendix 4, on the Completion date(s) given above. No credit will be given to earlier completion. Bids offering completion beyond the specified period are liable to be rejected.

- (d) any other relevant technical factors that the Purchaser deems necessary or prudent to take into consideration.
- (e) any deviations to the commercial and contractual provisions stipulated in the Bidding Documents.
- (f) details furnished by the bidder in response to the requirements specified in Volume-II of the Bidding Documents.
- (g) The acceptability of the vendors and subcontractors proposed in Attachment 5 to be used by the Bidder will be evaluated. Should a vendor or subcontractor, for the items other than those covered under Annexure-A(BDS), be determined to be unacceptable, the bid will not be rejected, but the Bidder will be required to substitute an acceptable vendor or subcontractor without any change to the bid price.

24.2 Where alternative technical solutions have been permitted and offered in Attachment 7 to the bid, the Purchaser will make a similar evaluation of the alternatives, which will be treated in the technical and commercial evaluations as if they were base bids. Where alternatives are not permitted, but have in any event been offered, they shall be ignored.

25. Opening of Second Envelope by Purchaser

- 25.1 The Second Envelope i.e., Price Part of only those Bidders shall be opened who are determined as having submitted substantially responsive bids and are ascertained to be qualified to satisfactorily perform the Contract, pursuant to ITB Clause 23 and 24. Such Bidders shall be intimated through uploading of notification on the websites about the date and time for opening of Price Part i.e., Second Envelope of the Bids by the Purchaser.
- 25.2 The Purchaser will open Second Envelope i.e., Price Part at the specified time and date in the presence of bidders" designated representatives who choose to attend, at the time & date in the intimation for opening of Second Envelope and location stipulated in NIT/IFB/BDS. The bidders" representatives who are present shall sign a register evidencing their attendance. Bidders who have submitted their bid and found qualified as mentioned at para 25.1 may view online tender opening on the portal from their end.
- 25.3 The bidders" names, the Bid Prices, including any alternative Bid Price or any discounts, and any such other details as per Electronic form filled in by the bidder on the portal will become viewable at the time of opening of bids. The prices and details as filled up in Electronic Form/Template by the bidder and opened during the bid opening and recorded in the Bid Opening Statement would not be construed to determine the relative ranking amongst the Bidders, or the successful Bidder, and would not confer any right or claim whatsoever on any Bidder. The successful Bidder (also referred to as the L1 Bidder) shall be determined as per the provisions of this Section – II and considered for award of contract as provided in ITB Clause 30.
- 25.4 The Purchaser shall prepare minutes of the bid opening, including the information disclosed to those present in accordance with ITB Sub-Clause 25.3.
- 25.5 Bids not opened and read out at bid opening shall not be considered further for evaluation, irrespective of the circumstances.

26. Conversion to Single Currency

- 26.1 The currency that shall be used for bid evaluation and comparison purposes to convert all bid prices expressed in various currencies into a single currency is: Indian Rupees (INR).

Exchange rate: To facilitate evaluation & comparison, the Employer will convert all the bid prices, expressed in the various currencies, to Indian Rupees at the rate of 1 INR (Indian Rupees) = 1.6 NPR (Nepalese Rupees).

27. **Evaluation of Second Envelope (Price Part)**

27.1 The Purchaser will examine the Price Part (Second Envelopes) to determine whether they are complete, whether any computational errors have been made, whether the documents have been properly signed, and whether the bids are generally in order.

The Price Part containing any deviations and omissions from the contractual and commercial conditions and the Technical Specifications which have not been identified in the First Envelope are liable to be rejected.

27.2 Arithmetical errors will be rectified on the following basis:

If there is a discrepancy between the unit price and the total price, which is obtained by multiplying the unit price and quantity specified by the Purchaser, or between subtotals and the total price, the unit or subtotal price shall prevail, and the quantity and the total price shall be corrected. However, in case of items quoted without indicating any quantity or the items for which the quantities are to be estimated by the Bidder, the total price quoted against such items shall prevail. If there is a discrepancy between words and figures, the amount in words will prevail.

If there is a discrepancy between the quantity specified by the Purchaser for the purpose of bidding and quantity indicated by the bidder in the corresponding price schedule(s), the quantity specified by the Purchaser shall prevail.

Further, if quantity of a particular item is split up between two or more price schedule(s) by the bidder in its bid and there is a discrepancy in the sum total of such split up quantity indicated by the bidder and the quantity specified by the Purchaser, then the discrepancy in the quantity shall be corrected in the following manner:

- In case quantity indicated by the bidder is in excess of the quantity specified by the Purchaser, the quantity indicated in the price schedule with the highest price shall be reduced in the first instance followed by reduction in other price schedule(s) in the descending order of prices to the extent of excess quantity.
- In case there is a shortfall in the quantity indicated by the bidder as compared to the quantity specified by the Purchaser, the quantity indicated in the price schedule with the lowest price shall be increased to the extent of shortfall in the quantity.

If correction of the quantity is necessitated due to the discrepancy in quantity as stated above, the liability of the Purchaser towards all taxes and duties considered for evaluation under the provisions of the bidding documents,

shall also be taken into account in addition to the quoted price.

Further, such correction in the quantity and the consequent corrected bid price shall be considered for the purpose of evaluation as well as award.

The prices of all such item(s) against which the Bidder has not quoted rates/amount (viz., items left blank or against which '-' is indicated) in the Price Schedules will be deemed to have been included in other item(s).

The subtotal, total price or the total bid price to be identified in Bid Form for this purpose, irrespective of the discrepancy between the amount for the same indicated in words or figures shall be rectified in line with the procedure explained above.

If the Bidder does not accept the correction of errors as per this clause, its bid will be rejected and the amount of Bid Security forfeited.

Rates should be filled in both figures and words. In case of ambiguities in between the rate in figures and the rate in words, the rate quoted in words shall prevail and the amount shall be corrected accordingly. The SAPDC reserves the right to adjust arithmetical or other errors in any tender/quotation in the way which it considers suitable.

- 27.3 The comparison shall be on the total price in Price Schedule No. 5 Grand Summary (Total of Schedule Nos. 1 to 3).

The comparison shall also include the applicable taxes, duties and other levies, which are reimbursable in line with the provisions of the Bidding Documents.

The Purchaser's comparison will also include the costs resulting from application of the evaluation procedures described in ITB Sub-Clause 27.4 & 27.5.

- 27.4 The Purchaser's evaluation of a bid will take into account, in addition to the bid prices indicated in Price Schedule Nos. 1 through 4 (Second Envelope), the following costs and factors that will be added to each Bidder's bid price in the evaluation using pricing information available to the Purchaser, in the manner and to the extent indicated in ITB Sub-Clause 27.5 and in the Technical Specifications:

- (a) the cost of all quantifiable deviations and omissions from the contractual and commercial conditions and the Technical Specifications as identified in the evaluation of First Envelope, and other deviations and omissions not so identified;
- (b) the performance of the Goods offered;

Bidder shall confirm the guaranteed performance or efficiency of the Goods in response to the Technical Specifications. Goods offered shall have minimum performance specified in Technical Specification to be considered responsive. Bids offering Goods with a performance less than the specified may be rejected.

- (c) any other relevant factors listed in **BDS**.

The estimated effect of the price adjustment provisions of the Conditions of Contract, applied over the period of execution of the contract, shall not be taken into account in bid evaluation.

27.5 Pursuant to ITB Sub-Clause 27.4, the following evaluation methods will be followed:

- (a) Contractual and commercial deviations

The evaluation shall be based on the evaluated cost of fulfilling the contract in compliance with all commercial, contractual and technical obligations under this Bidding Documents. In arriving at the evaluated cost, towards deviations whether material or minor identified in the evaluation of First Envelope, the cost of withdrawal indicated by the bidder in Attachment-6 of the First Envelope will be used. If such a price is not given except for material deviation, the Purchaser will make its own assessment of the cost of such a deviation for the purpose of ensuring fair comparison of bids.

In those cases, where the bidder has taken a material deviation but has not indicated the cost of withdrawal, the bid shall be treated as non-responsive and shall not be considered further.

- (b) Performance Guarantees of the Goods

For the purpose of evaluation, no adjustment to the bid price towards performance guarantees of the goods is applicable. However, the provision of Technical Specification, Volume-II of the Bidding Documents and Clause ITB 27.4 (b) shall prevail.

27.6 Any adjustments in price that result from the above procedures shall be added, for purposes of comparative evaluation only, to arrive at an "Evaluated Bid Price." Bid prices quoted by bidders and rectified as per ITB Sub Clause 27.2 shall remain unaltered.

28. Purchase/Domestic Preference

28.1 No margin of Purchase/ Domestic Preference will be allowed in evaluation and comparison of bids.

29. e-Reverse Auction (e-RA)

- 29.1 The Purchaser reserves the right to conduct e-Reverse Auction (e-RA) for further reduction in the price. In case e-RA is conducted, same shall be done in the manner as indicated at Annexure-B(BDS).

Further, intimation regarding e-RA shall be intimated to the prospective bidder through email or through uploading the notification on websites. All the bidding process is physical/offline mode except e-RA Portal for e-RA, which shall be intimated & arranged/provided by SAPDC on their cost.

30. Confidentiality and Contacting the Purchaser

- 30.1 After the public opening of bids, information relating to the examination, clarification, and evaluation of bids and recommendations concerning awards shall not be disclosed to Bidders or other persons not officially concerned with this process until the publication of contract award. From the time of bid opening to the time of contract award, if any Bidder wishes to contact the Purchaser on any matter related to its bid, it should do so in writing.

- 30.2 Any effort by a Bidder to influence the Purchaser in the Purchaser's bid evaluation, bid comparison or contract award decisions may result in rejection of the Bidder's bid. The Purchaser shall be the sole judge in this regard.

F. Award of Contract

31. Award Criteria.

- 31.1 Subject to ITB Clause 32, the Purchaser will award the contract to the successful Bidder (also referred to as L1 Bidder) whose bid has been determined to be substantially responsive and to be the lowest evaluated bid after e-RA(if conducted), further provided that the Bidder is determined to be qualified as per the Qualification Requirement specified in Annexure-A (BDS) to perform the contract satisfactorily.
- 31.2 The Purchaser may request the Bidder to withdraw any of the deviations listed in the winning bid.

At the time of Award of Contract, if so desired by the Purchaser, the bidder shall withdraw the deviations listed in Attachment 6 to the First Envelope at the cost of withdrawal stated by him in the bid. In case the bidder does not withdraw the deviations proposed by him, if any, at the cost of withdrawal stated by him in the bid, his bid will be rejected and his bid security forfeited.

Bidder would be required to comply with all other requirements of the Bidding

Documents except for those deviations which are accepted by the Purchaser.

31.3 The mode of contracting with the successful bidder will be as per stipulation outlined in GCC Sub-Clause 2.1 and briefly indicated below:

31.3.1 In the case of successful Nepalese Bidder the award shall be made as follows:

- (i) First Contract (Supply of Goods): For Ex-Works supply of all Goods and Type Tests to be conducted (whether in Nepal or abroad)
- (ii) Second Contract (Supply of Services): For providing all services i.e. inland transportation, In-transit insurance, loading and delivery at site and Supervision Charges, if applicable and any other services specified in the Contract Documents.

Both contracts will contain a cross fall breach clause specifying that breach of one will constitute breach of the other.

31.3.2 In the case of successful Foreign Bidder (i.e. Indian bidder), the award shall be made as follows:

- (i) First Contract (*Supply of Goods from Abroad (i.e. Outside Nepal)*): For CIP Entry Border Point supply of all Goods from abroad and Type Tests to be conducted abroad, if any.
- (ii) Second Contract (Supply of Services from within Nepal): For providing all services i.e. port handling and custom clearance of supplies from abroad, inland transportation, In-transit insurance, loading and delivery at site and Supervision Charges, if applicable and any other services specified in the Contract Documents.

Both the contracts will contain a cross fall breach clause specifying that breach of one will constitute breach of the other.

31.3.3 Deleted.

31.3.4 Compliance of applicable laws of the land in Nepal inter-alia including Taxation laws, guidelines etc shall be a necessary condition for release of payments to the Bidder/Contractor.

32. Purchaser's Right to Accept any Bid and to Reject any or all Bids

32.1 The Purchaser reserves the right to accept or reject any bid, and to annul the bidding process and reject all bids at any time prior to award of contract, without thereby incurring any liability to the affected Bidder or bidders or any obligation to inform the affected Bidder or bidders of the grounds for the Purchaser's action.

33. Notification of Award

- 33.1 Prior to the expiration of the period of bid validity, the Purchaser will notify the successful Bidder in writing, that its bid has been accepted. The notification of award will constitute the formation of the contract.
- 33.2 The Purchaser shall promptly respond in writing to any unsuccessful Bidder who, after notification of award in accordance with above, requests in writing the grounds on which its bid was not selected.
- 33.3 Upon the successful Bidder's furnishing of the performance security pursuant to ITB Clause 35, the Purchaser will promptly discharge the bid securities, pursuant to ITB Sub-Clause 13.4 & 13.5.

34. Signing the Contract Agreement

- 34.1 At the same time as the Purchaser notifies the successful Bidder that its bid has been accepted, the Purchaser in consultation with the Bidder will prepare the Contract Agreement provided in the Bidding Documents, incorporating all agreements between the parties.
- 34.2 The Contract Agreement shall be prepared within twenty-eight (28) days of the Notification of Award and the successful Bidder and the Purchaser shall sign and date the Contract Agreement immediately thereafter.

35. Performance Security

- 35.1 Within twenty-eight (28) days after receipt of the Notification of Award, the successful Bidder shall furnish the performance security for 3% (Three percent) of the contract price plus additional performance securities, if any, in line with the provisions of the Bidding Documents.

In addition to the Performance Security of 3% of the Contract Price, the successful bidder is required to furnish additional performance security(ies), if applicable, as per Clause no. 4 of Joint Deed of Undertaking mentioned at Sl. No. 14 of Section – VI : Sample Forms and Procedures.

- 35.2 Failure of the successful Bidder to comply with the requirements of ITB Clause 34 or Clause 35 shall constitute sufficient grounds for the annulment of the award and forfeiture of the bid security, in which event the Purchaser may make the award to the next lowest evaluated Bidder or call for new bids.

36. Fraud and Corruption

It is the Purchaser's policy that requires the Bidders, suppliers and contractors and their subcontractors under the contracts to observe the highest standard of ethics during the procurement and execution of such contracts. In pursuance of

this policy, the Purchaser:

- (a) defines, for the purpose of this provision, the terms set forth below as follows:
- (i) “Corrupt Practice” means offering, giving, receiving, or soliciting anything of value to influence the action of Purchaser official(s) in the procurement process.
 - (ii) “Fraudulent Practice” means any act including suppression/ misrepresentation of facts, submissions of forged/ false documents, making false declarations etc. that knowingly or recklessly misleads, or attempts to mislead, a party to obtain a financial gain or benefit, or to avoid an obligation, or to influence procurement process to the detriment of interest of the Purchaser, including collusive practices among bidders (prior to or after bid submission) to establish bid prices at artificial, non-competitive levels and to deprive Purchaser of the benefits of competitive prices.
 - (iii) “collusive practice” shall also include an arrangement between two or more parties designed to achieve an illegitimate purpose to the detriment of interest of Purchaser.
 - (iv) “coercive practice” is impairing or harming, or threatening to impair or harm, directly or indirectly, any party or the property of the party to influence improperly the actions of a party;
 - (v) “Obstructive practice” means
 - (aa) deliberately destroying, falsifying, altering or concealing of evidence material to the investigation or making false statements to investigators in order to materially impede investigation into allegations of a corrupt, fraudulent, coercive, or collusive practice; and/ or threatening, harassing or intimidating any party to prevent it from disclosing its knowledge of matters relevant to the investigation or from pursuing the investigation,
 - or
 - (bb) acts intended to materially impede the exercise of the contractual rights or audit or access to information.
- (b) will reject a proposal for award if it determines that the bidder recommended for award has, directly or through an agent, engaged in corrupt, fraudulent, collusive, coercive or obstructive practices in competing for the contract in question;

- (c) will sanction a firm or individual, including declaring ineligible, either indefinitely or for a stated period of time, to be awarded a contract if it at any time determines that the firm has, directly or through an agent, engaged in corrupt, fraudulent, collusive, coercive or obstructive practices in competing for, or in executing, a contract; and
- (d) will have the right to require that the provision be included in Bidding Documents and in contracts, requiring Bidders, suppliers, and contractors and their sub-contractors to permit the Purchaser to inspect their accounts and records and other documents relating to bid submission and contract performance and to have them audited by auditors appointed by the Purchaser.

37. Integrity Pact:

To improve transparency and fairness in the tendering process, SAPDC is implementing Integrity Pact. To improve transparency and fairness in the tendering process the Employer is implementing Integrity Pact. Integrity Pact is deemed as part of the contract so that the prospective bidders are bound by its provisions.

The Integrity Pact, signed by all the prospective Bidders and the Employer, shall commit the persons/officials of both the parties, not to exercise any corrupt/fraudulent/collusive/coercive practices in the Tendering process and also during implementation of the Contract. Only those Bidders who have entered into Integrity Pact with the Employer shall be eligible to participate in the bidding process. Bidders signing Integrity Pact shall not approach the Courts while representing the matters to IEMs and he/she will await their decision in the matter.

Entering into Integrity Pact as per Performa (Enclosed Schedule-F) is a basic qualifying requirement. In case of JV, each partner of JV shall sign Integrity Pact with the Employer. In case of sub-contracting, the Principal contractor shall be responsible for adoption of Integrity Pact by the sub-contractor.

To oversee the compliance of obligation under the Integrity Pact, a panel of Independent External Monitor(s) (IEMs) have been appointed by concerned authority. The Contact address of IEMs are as under:

| Sl. No. | Name of IEMs | Address of IEMs |
|---------|--|--|
| 1 | Sh. S.P. Srivastava, IPS (Retd.) | 1/125, Vineet Khand, Gomtinagar, Lucknow, UP-226010 Email: sps_ips@yahoo.com |
| 2 | Smt. Archana Pandey Tiwari, IRS (Retd.) | C-32, Nangal Dewat, Vasant Kunj, New Delhi-110070 Email: ampandey2001@yahoo.com |

The Integrity Pact duly signed on behalf of SAPDC is enclosed at Schedule-F of the Bid Document. The Integrity Pact shall be downloaded, printed and signed by the bidder and the hard copy shall be submitted in Part-I (Envelope-I).

----- End of Section-II (ITB) ---



VOLUME-I

SECTION – III

BID DATA SHEETS (BDS)



BID DATA SHEETS (BDS)

The following bid specific data for the Goods and Related Services to be procured shall amend and/or supplement the provisions in the Instruction to Bidders (ITB)

| Sl. No. | ITB Clause Ref. No. | Bid Data Details |
|---------|---------------------|---|
| 1. | ITB 1.1 | <p>The Owner is:</p> <p>SAPDC, Arun-3 HEP, Satluj Bhawan, Arun Sadan, Tumlingtar, Distt. Sankhuwasabha, Nepal</p> <p style="text-align: center;">Or</p> <p>SAPDC, Arun-3 HEP, 3rd Floor, Citizen Investment Trust(CIT) Building, Near to Investment Board of Nepal (IBN), New Bhaneshwor, Kathmandu</p> <p>Ph: +977 029-575154, +977 029-575141 Kind Attn.: Mr. Arun Dhiman, CEO, SAPDC</p> |
| 2. | ITB 1.1 | <p>The Purchaser is:</p> <p>SAPDC, Arun-3 HEP, Satluj Bhawan, Arun Sadan, Tumlingtar, Distt. Sankhuwasabha, Nepal</p> <p style="text-align: center;">Or</p> <p>SAPDC, Arun-3 HEP, 3rd Floor, Citizen Investment Trust(CIT) Building, Near to Investment Board of Nepal (IBN), New Bhaneshwor, Kathmandu</p> <p>Ph: +977 029-575154, +977 029-575141 Kind Attn.: Mr. Arun Dhiman, CEO, SAPDC</p> |
| 3. | ITB 1.1 | <p>Add new para:</p> <p>For execution of the subject Conductor Package CD03, Owner/Purchaser shall discharge their duties in accordance with agreement signed between them.</p> |
| 4. | ITB 5.4 | <p>Add new para:</p> <p>The nonrefundable fee towards the cost of Bidding Documents shall be</p> <p>NPR 10,000/- (For Nepalese bidders) or INR 7,000 equivalent to NPR 11,200/- (For Indian bidders) in the form of Manager's cheque (In original) (issued by a "A" Class Nepalese Bank shall only be acceptable) payable at</p> |

| Sl. No. | ITB Clause Ref. No. | Bid Data Details |
|---------|---------------------|---|
| | | <p>Khandbari, Nepal in favour of SJVN Arun-3 Power Development Company Pvt. Ltd.</p> <p>Any bid not accompanied by an acceptable Cost of Tender Document shall be rejected by SAPDC as non-responsive.</p> <p>Alternatively, payment against Cost of Tender Document may be made directly in the bank account of SAPDC as mentioned below:</p> <p>NPR Account Details: Everest Bank Limited Name: SJVN Arun-3 Power Development Company Pvt. Ltd. Acc. No. 00800105200477 Swift Code: EVBLNPKA</p> <p>However, if Bidder/Firm opt for submission of Tender document cost directly in the bank account of SAPDC, then the documentary evidence/ proof of same (swift statement/ transfer statement/ account statement) has to be submitted along with technical bid in Part-I(Envelope-I).</p> |
| 5. | ITB 6.2 | <p>Add new para:</p> <p>Pre-Bid Meeting (if required): Shall be intimated later separately on websites (www.sapdc.com.np, www.sjvn.nic.in and www.eprocure.gov.in) only.</p> <p>Further, the Bidder's designated representatives are invited to attend a pre-bid meeting(if required), which will take place in person or through Video Conferencing(Mode of Pre-bid Meeting shall be as decided by SAPDC). The web link to join the meeting shall be shared before the scheduled date of the meeting</p> |
| 6. | ITB 9. | <p>For these package, Bids from Joint Venture is not permitted.</p> |
| 7. | ITB 9 (I)(vi). | <p>Supplementing ITB Clause 9 (I)(vi) with the following</p> <p>(i) Joint Undertaking by the Licensor along with the Bidder (in Original), if applicable.</p> |
| 8. | ITB 9.1 (b)(f) | <p>Supplementing ITB Clause 9.1 (b)(f) with the following:</p> <p>(i) Joint Undertaking by the Licensor along with the Bidder (in Original), if applicable.</p> |

| Sl. No. | ITB Clause Ref. No. | Bid Data Details |
|---------|------------------------|--|
| 9. | ITB 9.2 | Alternative bids shall not be permitted |
| 10. | ITB 9.3 (c) | For these packages bids from joint venture is not permitted. |
| 11. | ITB 9.3 (o), (s), 16.1 | <p>Supplementing ITB 9.3 (o), (s) & 16.1 with the following:</p> <p>Note: It may be mentioned that in the Bidding Documents wherever in the provisions (for ex. regarding Joint Deed of Undertakings, Integrity Pact, Safety Pact etc.) specific conditions for Foreign Bidder is appearing, such conditions are also applicable for firms of Indian origin in line with clause ITB 2.1 in BDS, Section-III of the Bidding Documents. Further, in case of Nepalese Bidders they may provide all such Forms such as Joint Deed of Undertakings, Integrity Pact, Safety Pact etc. as indicated in ITB 5.1 on their Letter head.</p> |
| 12. | ITB 9.3 (q) | <p>Supplementing ITB clause 9.3(q) (iii) with the following:</p> <p>Detailed information regarding previous transgressions of Integrity Pact that occurred in the last 10 years with any other Public Sector Undertaking or Government Department or any other Company, in any country.</p> |
| 13. | ITB 9.3 (v) | <p>Add new Sub-Clauses as 9.3 (v) as below:</p> <p>(v) Attachment 21: Compliance to the process related to the e-RA Terms & Conditions and the Business Rules governing the e-RA</p> |
| 14. | ITB 15.1 (ii)(f) | <p>Supplementing ITB clause 15.1 (ii)(f) with the following:</p> <p>a) Joint Undertaking by the Licensor along with the Bidder (in Original), if applicable.</p> |
| 15. | ITB 17.1 | <p>Supplementing ITB clause 17.1 with the following:</p> <p>Hard Copy of the Joint Undertaking by the Licensor along with the Bidder (in Original), if applicable, must be submitted along with technical bid Envelope-I</p> |
| 16. | ITB 17.2.1 | <p>Supplement Clause ITB 17.2.1 as under:</p> <p>The e-mail IDs for the said purpose are as follows:</p> <p style="text-align: center;">Email IDs: pnc.sapdc@gmail.com</p> |

| Sl. No. | ITB Clause Ref. No. | Bid Data Details |
|---------|---------------------|---|
| 17. | ITB 23.2 | <p>Add new Sub Clauses ITB 23.2.1 to ITB 23.2.5 as under:</p> <p>23.2.1 The determination shall also take into account the assessment of Bid Capacity of a bidder before considering them for award of contract(s). Such Bid Capacity for regulating award of contract(s) on a bidder during any Financial Year (i.e. April to March) shall be subject to the condition that aggregate of the Minimum Average Annual Turnover (MAAT) requirement specified in Qualification Requirement (Annexure-A(BDS), Section-III, Volume-I of Bidding Documents) for various packages to be considered for award [shall mean the package(s) for which award has been placed on that Bidder/ Bidder is under the zone of consideration for award of the package(s)] during such Financial Year (i.e. April to March) shall not exceed 1.5 (one and half) times the Average Annual Turnover (AAT) of the Bidder worked out in the manner as specified in Qualification Requirement for the Bidder(Annexure-A(BDS), Section-III, Volume-I of Bidding Documents).</p> <p>23.2.1.1 In case of Joint Venture bids, the requirements specified in the Qualification Requirement for the individual partner(s) shall be taken into account for the above purpose. Further, the balance requirement of MAAT and Bid Capacity of the package (s), specified to be met by the Joint Venture cumulatively shall be apportioned to each of the partners in the ratio of the specified requirements for individual partner(s), however, in case of shortfall, if any, the available AAT and Bid Capacity of any of the partners shall be taken into account.</p> <p>23.2.2 Notwithstanding above, in case of Bidder(s) who are already executing contract(s) or has executed contract(s) in the past for the Purchaser, while assessing the capacity and capability of a Bidder, the Purchaser reserves the right to undertake Performance Review of the Bidder against such contract(s) and the outcome of the review shall be considered for award of additional contracts after considering all relevant aspects.</p> <p>23.2.3 For conductor, the bidder/manufacturer shall be considered to have the Manufacturing Capacity under various packages during a financial year (i.e. April to March) provided the annualized requirement of such item under the package(s) for which a bidder shall be considered for award</p> |

| Sl. No. | ITB Clause Ref. No. | Bid Data Details |
|---------|---------------------|--|
| | | <p>[shall mean the package(s) for which award has been placed on that bidder/bidder is under the zone of consideration for award of the package(s)] during the said financial year does not exceed 0.67 times the annual manufacturing capacity of the bidder/ manufacturer.</p> <p>The manufacturing capacity shall be based on as declared by the Power of Attorney holder and Key Managerial Person of the bidder and certified by a Chartered Engineer or similar Professional/ Professional body/Govt. Agencies in the country of the bidder/ manufacturer. However, this shall be further restricted to the balance manufacturing capacity net of the works under execution (i.e. manufacturing capacity available for further award) as declared by the bidder itself in the bid.</p> <p>23.2.4 Notwithstanding the declaration by the bidder as above, the Bid Capacity/ Manufacturing Capacity shall be subject to assessment, if any, by the Purchaser.</p> <p>23.2.5 The Bidder shall note that if at any stage, they have been found to resort to unethical practices inter-alia including any misrepresentation of facts, submission of false and/ or forged details/ documents/ declaration as above, the bidder may be debarred from the participation in Purchaser's tenders for a period of 1 to 3 years, as considered appropriate and its Bid Security/ Contract Performance Guarantee shall be forfeited besides taking other actions as deemed appropriate.</p> <p>23.2.6 Deleted</p> |
| 18. | ITB 23.5 | <p>Add new sub Clause ITB 23.5 as under :</p> <p>23.5 In case of new bidders, assessment shall be done as per the provisions of Qualification Requirement for the Bidder, enclosed as Annexure-A (BDS) taking into consideration all relevant aspects. The bidder's capacity and capability for award of Contract(s) shall be based on such assessment.</p> |
| 19. | ITB 23.6 | <p>Add new sub Clause 23.6 as under:</p> <p>23.6 For all above purposes, Purchaser shall be sole judge in this regard.</p> |

| Sl. No. | ITB Clause Ref. No. | Bid Data Details | | | |
|---------|---------------------|---|---|-------------------------------|--|
| 20. | ITB 24.1 (c) | The delivery schedule (i.e., Receipt at Site) for the Goods and Related Services to be supplied under the subject packages shall be as follows: | | | |
| | | Mile Stones | Duration in days from the date of Notification of Award | Quantity to be supplied in KM | Remarks |
| | | 1st | 90 | 500 KM | The Bidder is required to supply the Quantity mentioned as per time Schedule. The quantities mentioned are minimum i.r.o each milestone, however, bidder may supply additional quantities i.e upto 2799 KM . |
| | | 2nd | 120 | 1000 KM | |
| | | 3rd | 180 | 1299 KM | |
| | | Total Quantity to be supplied | | 2799 KM | |

----- End of Section-III-----

Annexure-A(BDS)

Conductor Package CD03 for supply of ACSR MOOSE Conductor for part of Diding – Dhalkebar – Bathnaha Transmission Line corresponding to Tower Package- TW02; associated with Arun-3 HEP in Nepal

SPECIFICATION NO(S). : SAPDC/P&C/Arun-3HEP/CD03/2023



Qualification of Bidder

Qualification of bidder will be based on meeting the minimum pass/fail criteria specified below regarding the Bidder's Technical Experience and Financial Position as demonstrated by the Bidder's responses in the corresponding Bid Schedules. The bid can be submitted by:

- (i) an individual firm meeting the Qualifying Requirement (QR), or
- (ii) a qualified licensee of a qualified manufacturer.

The Purchaser may assess the capacity and capability of the bidder, to ascertain that the bidder can successfully execute the scope of work covered under the package within stipulated completion period. The assessment shall inter-alia include (i) document verification; (ii) bidder's works/manufacturing facilities visit; (iii) manufacturing capacity, details of work executed, works in hand, anticipated in future & the balance capacity available for the present scope of work; (iv) details of plant and machinery, manufacturing and testing facilities, manpower and financial resources; (v) details of quality system in place; (vi) past experience and performance; (vii) customer feedback; (viii) Banker's feedback etc.

SAPDC reserves the right to waive minor deviations if they do not materially affect the capability of the Bidder to perform the contract.

1.1 Technical Experience:

- (a) The bidder shall be a manufacturer of Conductor. The bidder's experience should include the following:
 - (i) The bidder should have manufactured, tested and supplied at least one thousand (1000) Kms of Sixty one (61) or above strands of ACSR/AAAC conductor during last Seven (7) years as originally schedule date of bid opening i.e 01.03.2023.
- (b) However, if the bidder is not meeting the above requirements of its own, he should be a qualified Licensee of a qualified manufacturer meeting the above specified requirements and should also meet the following conditions:
 - (i) Manufacturer/Licensee shall have adequate design infrastructure and manufacturing facility and capacity and procedures including quality control.
 - (ii) A qualified Licensee of a qualified manufacturer shall comply with all of the following requirements and furnish a joint undertaking by the licensor along with the bidder in its bid as per proforma enclosed in Section 'FORMS' of Conditions of Contract, Vol-I:
 - a. Any design undertaken by the Licensee shall be approved by the Licensor.
 - b. Manufacturing by the Licensee shall be done with the approval of the Licensor and Purchaser under a quality assurance programme approved and monitored by the Licensor.

- c. Licensee must furnish back-up guarantee from the licensor for individual and overall performance of all materials supplied under the contract.
- d. Licensor must guarantee sequential and timely supply of materials and submission of technical information and data as desired by the Purchaser so as to meet the overall construction schedule and
- e. The agreement between Licensee and Licensor (*copy to be submitted along with the bid*) shall be valid for a period of at least five (5) years after the guarantee period of equipment and materials under supply is over.

In case bidder is a holding company, the technical experience referred to in clause 1.1 above shall be of that holding company only (i.e. excluding its subsidiary/group companies). In case bidder is a subsidiary of a holding company, the technical experience referred to in clause 1.1 above shall be of that subsidiary company only (i.e. excluding its holding companies).

1.2 Financial Position

a) Net worth for last 3 financial years should be positive.

b) Minimum Average Annual Turnover* (MAAT) for best three years i.e. 36 months out of last five financial years of the bidder should be:

i. Indian **Rs. 76.00 Crore** for Conductor Package(CD03)

* *Note: Annual Gross Revenue from operations/Gross operating income as incorporated in the profit & loss account excluding Other Income.*

c) Bidder shall have liquid assets (L.A) or/and evidence of access to or availability of credit facilities of not less than:

i. Indian **Rs. 40.00 Crore** for Conductor Package(CD03)

In case bidder is a holding company, the financial position criteria referred to in clause 1.2 above shall be of that holding company only (i.e excluding its subsidiary/group companies). In case bidder is a subsidiary of a holding company, the financial position criteria referred to in clause 1.2 above shall be of that subsidiary company only (i.e excluding its holding company).

d) In case of a bid submitted by a qualified Licensee of a qualified manufacturer, the requirements stipulated at Clause 1.2 above shall be individually met by the Licensee as well as the Licensor.

Annexure-B(BDS)

e-Reverse Auction (e-RA)

1. Based on L1 “Evaluated Bid Price” determined pursuant to ITB Sub Clause 27.6, the qualified bidders shall participate in E-Reverse auction process as follows:
2. Process:
 - a) Eligibility Criteria for participation in e-RA:
 - i. Only techno-commercially responsive bidders with valid digital signature certificate, who participate in the initial e-tendering process, will be eligible to participate in the subsequent e-RA.
 - ii. Where number of eligible bidders at Price bid stage is one, then work shall be awarded to sole bidder, if the price of sole bidder is found reasonable and acceptable to SAPDC.
 - iii. Where number of eligible bidders at Price bid stage is two/three, then e-RA process will be conducted among all bidders.
 - iv. Under no circumstances, there shall be less than two bidders participating in e-RA after elimination.
 - v. In case of eligible bidders at Price bid stage is four or more than four then, the highest (H1) bidder shall not be eligible for e-RA and e-RA will be conducted among rest of the bidders.
 - b) e-RA will be done on total bid price and the unit rates of the successful(L1) bidder quoted in e-tender shall be reduced pro-rata to match with the e-RA bid price.
 - c) After technical evaluation of the bids & opening of price bids, the bidders, eligible for e-RA as per methodology above, will be intimated. Such qualified bidders shall be eligible to participate in the e-RA to be conducted by the e-procurement/e-RA service provider.
 - d) e-Procurement/e-RA service provider will guide the shortlisted bidders for this purpose and the Bidders shall abide by Business Rules for e-RA as specified herein under.
- 2.1 Start/Base Price: For e-RA, L1 “Evaluated Bid Price” determined in accordance with ITB Sub Clause 27.6. shall be taken as start/base price.
- 2.2 e-RA will be conducted on scheduled date & time which shall be conveyed to the eligible bidders through e-mail.
- 2.3 The start/base price and the minimum bid decrement value shall be available to qualified bidders only on the e-procurement website, sixty minutes before the start of e-RA Process.

- 2.4 The first online bid for e-RA shall be lesser than the price by minimum one decrement (0.1% of L-1 evaluated price). The subsequent online bids will be lesser than the first online bid by minimum one decrement value. The final bid shall prevail over the earlier bids.
- 2.5 The bidder will be able to view leading bid in the auction and/or his own rank, bid placed by him during the event, Opening Price and Decrement price on screen along with other necessary fields in the e-RA. Names of bidders shall be displayed as dummy names to maintain anonymity.
- 2.6 e-RA duration: The duration of e-RA shall be initially for a period of one hour. However, in case any bidder places a bid within the last 10 minutes before scheduled closing of the e-RA and if the bid gets accepted and happens to be lowest, the duration for e-RA shall be increased by a further period of 10 minutes beyond scheduled closing time.
Auto-extension: The auto-extension takes place only in the last 10 minutes and there will be no limits for number of auto-extensions. However, in case there is no bid in the last 10 minutes before the closing of e-RA, then e-RA shall get closed automatically.
- 2.7 Proxy Reverse Auction feature: It is a pro-bidder feature to safe guard bidder's interest against Internet failure or in case of bidders who don't wish to be present in entire e-RA duration but wish to quote a minimum price that is valid for them in entire e-RA duration. This feature allows bidders to place an automated bid against other bidders in the e-RA without having to enter revised bid again and again during the e-RA process. The proxy bid amount cannot be changed until the lowest bidding amount reaches the proxy bid amount, after which it can be lowered. Bids shall be submitted by the system on behalf of the proxy bidder in decrements i.e. decreasing bid amounts upto the proxy bid amount.
- 2.8 Bidders shall submit most competitive prices through e-tendering since these prices may be considered for final award in case e-RA event is not resorted to, due to reasons mentioned herein.
- 2.9 At the end of e-RA, the closing/final Price shall be available on screen. The ratio of closing/final price through e-RA and originally quoted price through e-tendering shall be applied on all elements of originally quoted price to arrive at the final price break up (i.e. unit rates) which shall be considered further for final award.
- 2.10 Loading: Techno-commercial cost loading (for non-compliance to Employer's terms and conditions as applicable), if any will be carried out/or the deviations taken by the bidder and to determine the lowest evaluated bid. It shall be intimated to bidders prior to e-RA event and it shall be added to the quoted

prices of respective bidder. Accordingly, the bidder(s) during e-RA should submit prices inclusive of cost of withdrawal of their respective deviations and/or other loadings so evaluated and intimated by the Employer.

After the completion of e-RA, the Closing Price (CR) shall be available. In case, any commercial loading is made to L1 bidder's price, it shall be de-loaded from the closing price of L1 bidder (CP) for further arriving at final breakup (i.e., Unit Prices) and thereafter processing for award.

- 2.11 Cancellation: During e-RA, if no bid is received within the specified time duration of the e-RA, Employer, at its sole discretion, may decide to reschedule/scrap the e-RA process or finalize the tender based on Price Bids received through e-tendering if Employer does not decide to cancel/annul the tendering process for any reason and if the price of lowest bidder is found reasonable and acceptable to the Employer.
- 2.12 On the basis of these terms and conditions, Employer, at any time before the placement of order on successful bidder, shall be at liberty to cancel, extend, reschedule the e-RA process or finalize the tender based on Price Bids submitted through e-tendering without assigning any reason.
- 2.13 Award: On the conclusion of e-RA successful bidder shall be the one whose e-RA price is lowest (In pursuance to ITB Clause31) if considered reasonable at the sole discretion of Employer.
- 2.14 Employer's decision for award of Contract shall be final and binding on all the bidders.
- 2.15 Limitation of Liability: Employer or its e-procurement/e-RA service provider shall not be liable & responsible to bidders in any manner whatsoever for failure to access/interruption/delay & bid on the e-RA platform due to loss of internet connectivity, power failure, virus attack, problems with the PC, any other unforeseen circumstances etc. before or during the auction event. On account of this, the time for the auction shall not be extended and Employer shall not be responsible for such eventualities. Further, in such cases, the decision of Employer shall be binding on the bidders.
- 2.16 Employer reserves the right to modify/withdraw any of the Business rules, terms & conditions of e-RA at any point of time prior to commencement of e-RA. However, any modifications in Business rules, terms & conditions of e-RA shall be duly communicated to techno-commercially qualified bidders.

-
- 2.17 Employer will provide the calculation sheet to the bidders as applicable which will help them to arrive at the total cost to enable them to keep it ready during e-RA.
- 2.18 The e-RA would be carried out in Indian Rupees only.
- 2.19 System Accessibility: The login ID and password for participating in e-RA will be the same as the one given to bidders on registration on e-procurement portal.
- 2.20 In case of any issue w.r.t. e-RA not specifically dealt with in Business Rules, the decision of the Employer shall be final and binding on all concerned.



Annexure-C(BDS)

SAMPLE FORMAT for e-REVERSE AUCTION NOTICE

(EVENT INFORMATION)

| | | |
|---|--|---|
| EMPLOYER NAME | SAPDC, Arun-3 HEP, Satluj Bhawan, Arun Sadan, Tumlingtar, Distt. Sankhuwasabha, Nepal or SAPDC, Arun-3 HEP, 3 rd Floor, Citizen Investment Trust(CIT) Building, Near to Investment Board of Nepal(IBN), New Bhaneshwor, Kathmandu | |
| DATE & TIME OF REVERSE AUCTION | e-Reverse Auction Date : xx/yy/2023 e-Reverse Auction Time: From aa Hrs (IST) To bb Hrs (IST) | |
| AUCTION TO BE CONDUCTED BY | Shall be intimated to all the eligible bidders alongwith e-Reverse Auction Notice | |
| SAPDC OFFICIALS | Shall be intimated to all the eligible bidders alongwith e-Reverse Auction Notice | Shall be intimated to all the eligible bidders alongwith e-Reverse Auction Notice |
| VALUE OF MINIMUM DECREMENT | In the equivalent value of Indian currency. (0.1% of L-1 evaluated price) | |
| DOCUMENTS ATTACHED | PRICE CALCULATION SHEET (EXCEL SHEET)/ TEMPLATES (Attachment-1) <i>(Price Calculation Sheet (Excel Sheet)/ Templates shall be intimated to all the successful bidders alongwith e-Reverse Auction Notice).</i> | |

VOLUME-I

SECTION – IV

GENERAL CONDITION OF CONTRACT (GCC)

TABLE OF CLAUSES

Preamble

A. Definitions and Interpretation

1. **Definitions**
2. **Interpretation**

B. Subject Matter of Contract

3. **Scope of Supply**
4. **Delivery Schedule**
5. **Supplier's Responsibilities**
6. **Purchaser's Responsibilities**

C. Payment

7. **Contract Price**
8. **Terms of Payment**
9. **Securities**

10. **Taxes and Duties**

D. Intellectual Property

11. **Copy Right**
12. **Confidential Information**

E. Execution of the Contract

13. **Representatives**
14. **Work Program**
15. **Subcontracting**
16. **Design and Engineering**
17. **Goods & Related Services**
18. **Supervision of Installation**
19. **Test and Inspection**
20. **Completion**

F. Guarantees and Liabilities

21. **Completion Time Guarantee**
22. **Defect Liability**
23. **Equipment Performance Guarantees**
24. **Patent Indemnity**



- 25. **Limitation of Liability**
- G. **Risk Distribution**
 - 26. **Transfer of Ownership**
 - 27. **Loss of or Damage to Property; Accident or Injury to Workers; Indemnification**
 - 28. **Insurance**
 - 29. **Change in Laws and Regulations**
 - 30. **Force Majeure**
- H. **Change in Contract Elements**
 - 31. **Change in the Facilities**
 - 32. **Extension of Time**
 - 33. **Termination**
 - 34. **Assignment**
- I. **Resolution of Disputes**
 - 35. **Settlement of Disputes**
 - 36. **Arbitration**



GENERAL CONDITIONS OF CONTRACT (GCC)

Preamble

This Section (Section –IV) of the Bidding Documents [named as General Conditions of Contract (GCC)] provides all the rights and obligations of the parties under the Contract. This Section contains provisions that are to be used unchanged unless Section – V [named as Special Conditions of Contract (SCC)] states otherwise as any changes in GCC or any complementary information that may be needed has been shown in SCC. If there is a conflict between the provisions of Section – IV & Section – V, the provisions of Section – V shall prevail.



A. Definitions and Interpretation

1. Definitions

1.1 The following words and expressions shall have the meanings hereby assigned to them:

- (a) “Arbitrator” means the person or persons appointed by agreement between the Purchaser and the Supplier to make a decision on or to settle any dispute or difference between the Purchaser and the Supplier referred to him or her by the parties pursuant to GCC Sub-Clause 36.1 (Arbitration) hereof.
- (b) “Collaborator” or “Parent Company” means the firms/corporations who has provided technological support to the manufacturer for establishing production line for the specific equipment.
- (c) “Commissioning” means operation of the Goods by the Purchaser, as specified in the Technical Specifications on completion of all works as well as successful completion of Pre- commissioning of the Facilities where the Goods have been installed.
- (d) “Completion” means the delivery of Goods and fulfillment of the Related Services by the Supplier in accordance with the terms and conditions set forth in the Contract and Commissioning of the aforesaid Goods by the Purchaser through a Contractor.
- (e) “Contract” means the Contract Agreement entered into between the Purchaser and the Supplier together with the Contract Documents referred to therein.
- (f) “Contract Documents” means the documents listed in Clause 1.1 of Article 1 (Contract Documents) of the Form of Contract Agreement (including any amendments thereto).
- (g) “Contract Price” means the sum specified in Clause 2.1 of Article 2 (Contract Price) of the Contract Agreement, subject to such additions and deductions therefrom, as may be made pursuant to the Contract. For the purpose of Liquidated Damages and Contract Performance Guarantee, the “Contract Price” means the sum specified in Clause 2.1 of Article 2 (Contract Price) of the Contract Agreement.
- (h) “Contractor” means the firms appointed by the Purchaser for actual installation of the Goods to be supplied under the Contract.
- (i) “Day” means calendar day of the Gregorian Calendar.



- (j) “Defect Liability Period” means the period of validity of the warranties given by the Supplier during which the Supplier is responsible for defects with respect to the Goods as provided in GCC Clause 22 (Defect Liability) hereof.
- (k) “Delivery Schedule” means the time within which the delivery of Goods at final destination site is to be attained by the Supplier in accordance with the specifications, as a whole (or of a part of the Facilities where a separate Delivery Schedule of such part has been prescribed in the SCC).
- (l) “Effective Date” means the date of Notification of Award from which the Delivery Schedule shall be determined.
- (m) “Facilities” means the permanent plant to be established by the Purchaser/Contractor wherein the Goods to be supplied under the Contract are to be incorporated.
- (n) “GCC” means the General Conditions of Contract hereof.
- (o) “Goods” means all the commodities, raw material, machinery and equipment and/or other materials that the Supplier is required to supply to the Purchaser under the Contract.
- (p) “Licensee” means the party to whom the Licensor transfers (in whole or in part) the property rights including the entire know-how and know-why (as per terms and conditions mutually agreed to) to use that technology or produce product or system based on this technology for commercial purposes.
- “Licensee” has the rights to adopt and develop the technology and to spin off product for which he is having the ownership rights.
- (q) “Licensor” means the party who holds the licenses for a particular technology/product and also he is the owner of the property rights for the lifetime and location.
- (r) “Month” means calendar month of the Gregorian Calendar.
- (s) “Notification of Award” means the official notice issued by the Purchaser notifying the Supplier that his bid has been accepted.
- (t) “Owner” means the firm/corporation/government entity, named in the SCC, who has decided to set up the Facilities and shall include the legal successors or permitted assigns of the Owner.
- (u) “Project Manager” means the person appointed by the Purchaser in the manner provided in GCC Sub-Clause 13.1 hereof to perform the duties



delegated by the Purchaser.

- (v) "Project Site" means the such land and other places as may be specified in the Contract as forming part of the Site, upon which the Goods are to be supplied.
- (w) "Purchaser" means the firm/corporation/ government entity, named in the SCC, who is purchasing the Goods and Related Services. The Purchaser may be Owner himself or an agency appointed by the Owner and shall include the legal successors or permitted assigns of the Purchaser.
- (x) "Related Services" means the services incidental to the supply of the goods, such as insurance, installation, training, supervision of installation and initial maintenance and other such obligation of the Supplier under the Contract.
- (y) "SCC" means the Special Conditions of Contract.
- (z) "Subcontractor"/"vendor"/"sub-vendor" means firms/ corporations/ government entities to whom of any part of the Goods to be supplied or execution of any part of the Related Services is sub-contracted directly or indirectly by the Supplier with the consent of the Purchaser in writing, and includes its legal successors or permitted assigns.
- (aa) "Supplier" means the firms whose bid to perform the Contract has been accepted by the Purchaser and is named in the Contract Agreement, and includes the legal successors or permitted assigns of the Supplier.
- (bb) "Supplier"s Representative" means any person nominated by the Supplier and approved by the Purchaser in the manner provided in GCC Sub-Clause 13.2 (Supplier"s Representative) hereof to perform the duties delegated by the Supplier.
- (cc) "Taking Over" means the Purchaser"s written acceptance of the Goods and Related Services under the Contract, after Supplier"s performance obligation, in accordance with the Contract, as provided in GCC Sub-Clause 20.4.
- (dd) "Associate" means a party who has been conjoined by the Supplier to independently execute a pre-selected part of the contract and grant him the associated contractual rights and obligations, without diluting the overall responsibility of the Supplier in respect of the supply of Goods under the contract.
- (ee) Websites means www.sapdc.com.np, www.sjvn.nic.in and www.eprocure.gov.in. & e-portal means <https://sjvn.nic.in>



2. Interpretation

2.1 Contract

2.1.1 The Contracts to be entered into with the successful Bidder shall be as under:

In the case of successful Foreign Bidder (i.e. Indian bidder), the award shall be made as follows:

- (i) First Contract (Supply of Goods from Abroad (i.e. Outside Nepal)): For CIP Entry Border Point supply of all Goods from abroad and Type Tests to be conducted abroad, if any.
- (ii) Second Contract (Supply of Services from within Nepal): For providing all services i.e. port handling and custom clearance of supplies from abroad, inland transportation, In-transit insurance, loading and delivery at site and Supervision Charges, if applicable and any other services specified in the Contract Documents.

Both the contracts will contain a cross fall breach clause specifying that breach of one will constitute breach of the others.

In the case of successful Nepalese Bidder, the award shall be made as follows:

- (i) First Contract (Supply of Goods from within Nepal): For Ex-Works supply of all Goods and Type Tests to be conducted (whether in Nepal or abroad)
- (ii) Second Contract (Supply of Services from within Nepal): For providing all services i.e. inland transportation, In-transit insurance, loading and delivery at site and Supervision Charges, if applicable and any other services specified in the Contract Documents.

Both the above contract shall contain a cross fall breach clause specifying that breach of one will constitute breach of the other.

2.1.2 The award of three separate Contracts (in case of foreign bidder) shall not in any way dilute the responsibility of the Supplier for the successful performance of the contract as per Specification and a breach in one Contract shall automatically be construed as a breach of the other Contract which will confer a right on the Purchaser to terminate the other Contract also at the risk and the cost of the Supplier.

2.1.3 Deleted

2.1.4 Deleted

2.1.5 The Contract will be signed in two originals and the Supplier shall be provided with one signed original and the rest will be retained by the Purchaser.



2.1.6 The Supplier shall provide free of cost to the Purchaser all the engineering data, drawing and descriptive materials submitted with the bid, in at least two (2) copies to form a part of the Contract immediately after Notification of Award

2.2 Contract Documents

All documents forming part of the Contract (and all parts thereof) are intended to be correlative, complementary and mutually explanatory, subject to Article 1.2 (Order of Precedence) of the Contract Agreement. The Contract shall be read as a whole.

2.3 Language

The ruling language of the Contract and the language for communications shall be English.

2.4 Singular and Plural

The singular shall include the plural and the plural the singular, except where the context otherwise requires.

2.5 Headings

The headings and marginal notes in the General Conditions of Contract are included for ease of reference, and shall neither constitute a part of the Contract nor affect its interpretation.

2.6 Entire Agreement

Subject to GCC Sub-Clause 12.4 hereof, the Contract constitutes the entire agreement between the Purchaser and Supplier with respect to the subject matter of Contract and supersedes all communications, negotiations and agreements (whether written or oral) of parties with respect thereto made prior to the date of Contract.

2.7 Amendment

No amendment or other variation of the Contract shall be effective unless it is in writing, is dated, expressly refers to the Contract, and is signed by a duly authorized representative of each party hereto.

2.8 Independent Contractor

The Supplier shall be an independent contractor performing the Contract. The Contract does not create any agency, partnership, joint venture or other joint relationship between the parties hereto.

Subject to the provisions of the Contract, the Supplier shall be solely responsible for the manner in which the Contract is performed. All employees, representatives or Subcontractors engaged by the Supplier in



connection with the performance of the Contract shall be under the complete control of the Supplier and shall not be deemed to be employees of the Purchaser, and nothing contained in the Contract or in any subcontract awarded by the Supplier shall be construed to create any contractual relationship between any such employees, representatives or Subcontractors and the Purchaser.

2.9 Deleted

2.10 Non-Waiver

2.10.1 Subject to GCC Sub-Clause 2.10.2 below, no relaxation, forbearance, delay or indulgence by either party in enforcing any of the terms and conditions of the Contract or the granting of time by either party to the other shall prejudice, affect or restrict the rights of that party under the Contract, nor shall any waiver by either party of any breach of Contract operate as waiver of any subsequent or continuing breach of Contract.

2.10.2 Any waiver of a party's rights, powers or remedies under the Contract must be in writing, must be dated and signed by an authorized representative of the party granting such waiver, and must specify the right and the extent to which it is being waived.

2.11 Severability

If any provision or condition of the Contract is prohibited or rendered invalid or unenforceable, such prohibition, invalidity or unenforceability shall not affect the validity or enforceability of any other provisions and conditions of the Contract.

2.12 Country of Origin

"Origin" means the place(India/Nepal) where the goods have been mined, grown, produced, manufactured or processed; or through manufacturing, processing or substantial assembling of components, a commercially recognized product results that is substantially different in basic characteristics or in purpose or utility from its components.

2.13 Notices

2.13.1 Unless otherwise stated in the Contract, all notices to be given under the Contract shall be in writing, and shall be sent by personal delivery, special courier, telegraph, facsimile or Electronic Data Interchange (EDI) to the address of the relevant party set out in the Contract Agreement, with the following provisions:

- (a) Any notice sent by telegraph, facsimile or EDI shall be confirmed within two (2) days after dispatch by notice sent by special courier, except as

otherwise specified in the Contract.

- (b) Any notice sent by special courier shall be deemed (in the absence of evidence of earlier receipt) to have been delivered ten (10) days after dispatch. In proving the fact of dispatch, it shall be sufficient to show that the envelope containing such notice was properly addressed, stamped and conveyed to the postal authorities or courier service for transmission by special courier. Provided further that whenever the postal authorities or courier service provide a proof of delivery, the same shall also be applicable for presenting the fact of dispatch.
- (c) Any notice delivered personally or sent by telegraph, facsimile or EDI shall be deemed to have been delivered on date of its dispatch.
- (d) Either party may change its postal, facsimile or EDI address or addressee for receipt of such notices by ten (10) days" notice to the other party in writing.

2.13.2 Notices shall be deemed to include any approvals, consents, instructions, orders and certificates to be given under the Contract.

2.14 Governing Law & its Jurisdiction

The Contract shall be governed by and interpreted in accordance with laws of Nepal and the Courts of Nepal shall have exclusive jurisdiction in all matters arising under this Contract.

B. Subject Matter of Contract

3. Scope of Supply

- 3.1 Unless otherwise expressly limited in the Technical Specifications, the Supplier's obligation shall include the provision of all Goods and the performance of all Related Services required for the design, the manufacture (including procurement, quality assurance and delivery) of the Goods and the supervision of installation, commissioning and performance testing of the Goods in accordance with the plans, procedures, specifications, drawings, codes and any other documents as specified in the Technical specifications. Such specifications include, but are not limited to, the provision of supervision and engineering services; the supply of labour, materials, equipment, spare parts (as specified in GCC Sub-Clause 3.3 below) and accessories; Supplier's Equipment; temporary materials, structures and facilities; transportation (including without limitation, unloading and hauling to, from and at the Site); and storage.
- 3.2 The Supplier shall, unless specifically excluded in the Contract, perform all such work and/or supply all such items and materials not specifically mentioned in the Contract but that can be reasonably inferred from the

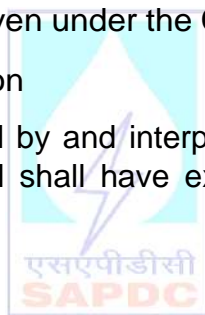



Contract as being required for attaining Completion of the Goods and Related Services as if such work and/or items and materials were expressly mentioned in the Contract.

- 3.3 The supply of Mandatory Spare Parts, if any, shall be included in the Contract. Beside the aforesaid Mandatory Spares parts, the Supplier shall ensure the availability of spare parts required for the operation and maintenance of the Goods to the Purchaser for a minimum period of 15 years from Completion of the Facilities. The Supplier shall carry sufficient inventories to ensure an ex-stock supply of consumable spares for the Goods. If so desired by the Purchaser, the Supplier shall submit the specifications, price and the terms and conditions relating to the supply thereof for such spares identified by the Purchaser with validity period of 6 months within 30 days of receipt of request from Purchaser for its consideration and placement of order.
- 3.4 The Supplier shall guarantee that in the event of termination of production of spare parts by the Supplier or his Sub-Contractor:
- (i) The Supplier shall send advance notification to the Purchaser of the pending termination, with 2 (two) years time to permit the Purchaser to procure needed requirements, and
 - (ii) Following such termination, the Supplier shall furnish at no cost to the Purchaser the blueprints, drawings and specification of the spare parts, if requested.
- 3.5 In case the Supplier fails to supply the spares parts in accordance with the terms stipulated above, the Purchaser shall sanction the Supplier declaring them ineligible for a stated period of time for future projects.

4. Delivery Schedule

- 4.1 Time for Completion is the essence of Contract. The Supplier shall commence the delivery of Goods to final destination site and shall attain completion of the delivery of Goods to final destination site in accordance with the time schedule specified in the corresponding Appendix – 4 (Delivery Schedule) to the Contract Agreement or within such extended time to which the Supplier shall be entitled under GCC Clause 32 hereof.

5. Supplier's Responsibilities

- 5.1 The Supplier shall design, manufacture (including associated purchases and/or subcontracting) and supply the Goods with due care and diligence in accordance with the Contract.
- 5.2 The Supplier confirms that it has entered into this Contract on the basis of a



proper examination of the data relating to the Goods provided by the Purchaser, and on the basis of information that the Supplier could have obtained from a visual inspection of the Site (if access thereto was available) and of other data readily available to it relating to the Goods as of the date twenty-eight (28) days prior to bid submission. The Supplier acknowledges that any failure to acquaint itself with all such data and information shall not relieve its responsibility for properly estimating the difficulty or cost of successfully performing the Facilities.

- 5.3 The Supplier shall acquire in its name all permits, approvals and/or licenses from all local, state or national government authorities or public service undertakings in the country where the Site is located that are necessary for the performance of the Contract, including, without limitation, visas for the Supplier's and Subcontractor's personnel and entry permits for all imported Supplier's Equipment. The Supplier shall acquire all other permits, approvals and/or licenses that are not the responsibility of the Purchaser under GCC Sub-Clause 6.1 hereof and that are necessary for the performance of the Contract.

Wherever required, the Supplier has to open Liaison office/Bank Account in Nepal complying with all applicable laws and regulations of Government of Nepal.

- 5.4 The Supplier shall comply with all laws in force in Nepal. The laws will include all local, state, national or other laws that affect the performance of the Contract and bind upon the Supplier. The Supplier shall indemnify and hold harmless the Purchaser from and against any and all liabilities, damages, claims, fines, penalties and expenses of whatever nature arising or resulting from the violation of such laws by the Supplier or its personnel, including the Subcontractors and their personnel.
- 5.5 All the Goods and Related Services to be supplied under the Contract shall have their origin as specified under GCC Sub-Clause 2.12 (Country of Origin).
- 5.6 The Supplier shall permit the Purchaser to inspect the Supplier's accounts and records relating to the performance of the Supplier.
- 5.7 Supplier shall not be entitled to claim cost compensation for the delay in obtaining permits, approvals and/or licenses necessary for the execution of the Contract as mentioned in GCC Clause 6.

6. Purchaser's Responsibilities

- 6.1 The Purchaser shall acquire and pay for all permits, approvals and/or licenses from all local, state or national government authorities or public service undertakings in the country where the Site is located which such authorities or undertakings require the Purchaser to obtain them in the



Purchaser's name, are necessary for the execution of the Contract (they include those required for the performance by both the Supplier and the Purchaser of their respective obligations under the Contract).

- 6.2 If requested by the Supplier, the Purchaser shall use its best endeavors to assist the Supplier in obtaining in a timely and expeditious manner all permits, approvals and/or licenses necessary for the execution of the Contract from all local, state or national government authorities or public service undertakings that such authorities or undertakings require the Supplier or Subcontractors or the personnel of the Supplier or Subcontractors, as the case may be, to obtain.
- 6.3 All costs and expenses involved in the performance of the obligations under this GCC Clause 6 shall be the responsibility of the Supplier.

C. **Payment**

7. **Contract Price**

- 7.1 The Contract Price shall be as specified in Article 2 (Contract Price and Terms of Payment) of the Form of Contract Agreement.
- 7.2 The Contract Price shall be subject to adjustment in accordance with the provisions of Appendix 2 (Price Adjustment) to the Contract Agreement. The Contract Price shall be increased or reduced on account of variation in quantity in accordance with Clause 31 of GCC.
- 7.3 Subject to GCC Sub-Clause 5.2 hereof, the Supplier shall be deemed to have satisfied itself as to the correctness and sufficiency of the Contract Price, which shall, except as otherwise provided for in the Contract, cover all its obligations under the Contract.

8. **Terms of Payment**

- 8.1 The Contract Price shall be paid as specified in the corresponding Appendix - 1 (Terms and Procedures of Payment) to the Contract Agreement. The procedures to be followed in making application for and processing payments shall be those outlined in the same Appendix.
- 8.2 Except otherwise stated in Appendix-1 (Terms and Procedure of Payment) to the Contract Agreement, the payments under the Contract shall be made in the currency or currencies in which the Contract Price has been stated in Contract Agreement, subject to the general principle that payments will be made in the currency or currencies in which the Contract Price has been stated in the Supplier's bid.

9. **Securities**



9.1 Issuance of Securities

The Supplier shall provide the securities specified below in favor of the Purchaser at the times, and in the amount, manner and form specified below.

9.2 Advance Payment Security

9.2.1 The Supplier shall, within twenty-eight (28) days of the notification of contract award, provide a security in an amount equal to:

a. 110% (one hundred ten percent) of the amount of Advance for CIP Entry Border Point Supplies from abroad (i.e. from outside Nepal).

b. 110% (one hundred ten percent) of the amount of Advance for Supply of Goods from within Nepal;

The above shall be calculated in accordance with the corresponding Appendix - 1 (Terms and Procedures of Payment) to the Contract Agreement, and in the same currency(ies) with initial validity of up to ninety (90) days beyond the completion of delivery of the Goods at the final destination sites under the Contract. The same shall be extended by the Supplier time to time till ninety (90) days beyond the actual date of completion of delivery of the Goods, as may be required under the Contract.

9.2.2 The security shall be in the Form of unconditional Bank Guarantee attached hereto in Section VI - Sample Forms and Procedures. The security shall be discharged after completion of delivery of the Goods under the contract and issuance of the Material Acceptance Certificate by the Purchaser's representative corresponding to which advance has been drawn.

- Procedure for effective reduction in the Advance Payment Security

The Advance Payment Security shall be allowed to be reduced every six (06) months after First Running Account Bill/Stage payment under the Contract if the validity of the Bank Guarantee is more than one year. The cumulative amount of reduction at any point of time shall not exceed seventy five percent (75%) of the advance corresponding to cumulative value of the supplies completed as per a certificate to be issued by the Project Manager. It should be clearly understood that reduction in the value of advance Bank Guarantee shall not in any way dilute the Supplier's responsibility and liabilities under the Contract including in respect of the supplies for which reduction in the value of security is allowed.



9.3 Performance Security

9.3.1 The Supplier shall, within twenty-eight (28) days of the notification of award, provide a performance security for the due performance of the Contract in the amount equivalent to Three percent (03%) of the Contract Price, with a validity upto ninety (90) days beyond the Defect Liability Period. The same shall be extended by the Supplier time to time till ninety (90) days beyond the actual Defect Liability Period, as may be required under the Contract.

Apart from the Supplier's performance security, the Supplier shall be required to arrange additional performance securities, as specified in bidding document, within twenty-eight (28) days of the notification of award in favour of the Purchaser in the form acceptable to the Purchaser.

In addition to the Performance Security of 03% of the Contract Price, the successful bidder is required to furnish additional performance security(ies), if applicable, as per Clause no. 4 of Joint Deed of Undertaking mentioned at Sl. No. 14 of Section – VI : Sample Forms and Procedures.

9.3.1.1 Notwithstanding above, in case of the performance security (ies) for which the validity as per GCC Clause 9.3.1 is required to be more than 2 years, the Supplier may choose to submit the performance security with initial validity of 2 years. In such cases, the Supplier shall, however be required to extend the validity till ninety (90) days beyond the actual Defect Liability Period, as may be required under the Contract at any time, but no later than 6 months, prior to expiry of the performance security failing which the said performance security shall be forfeited by the Purchaser.

9.3.1.2 If the Supplier delays submission of the performance security(ies) vis-à-vis the period specified in Clause GCC 9.3.1.1, then without prejudice to any other rights or remedies available with the Employer, following shall also be applicable:

- a) The Defect Liability Period pursuant to Clause GCC 22 for the Facilities or any relevant part thereof covered under the said performance security shall stand extended and the Supplier shall accordingly extend the validity of the Contract Performance Security to be furnished as per Clause GCC 9.3.1 by the period of delay as per Clause GCC 9.3.1.2 (c), over and above the period required as per the Contract.
- b) Alternatively, if the Supplier fails to extend the validity of the performance security pursuant to Clause GCC 9.3.1.2(a), an amount @preailing SBI Card Rate applicable for Inland Bank Guarantee +2% per annum on the performance security amount corresponding to the



Facilities or any relevant part thereof covered under the said performance security, for the period of delay as per Clause GCC 9.3.1.2 (c) shall be paid by the Supplier to the Purchaser. The Purchaser may, without prejudice to any other method of recovery, deduct the amount worked out as above from any monies due or to become due to the Supplier under the Contract.

- c) The period of delay for the above purpose shall be the time elapsed between the due date for submission of performance security as per the Contract and the date of performance security.
- d) In case the Supplier fails to submit the performance security within 90 days of the Notification of Award, the Employer, without prejudice to any other rights or remedies it may possess under the Contract, may consider the bid submitted by the Supplier/ Contractor in future packages as non-responsive in line with ITB 13.6, may forfeit the bid security and/or may terminate the Contract forthwith pursuant to GCC Clause 33.

9.3.1.3 The above extension of Defect Liability Period or deduction shall not relieve the Supplier from any of his obligations and liabilities under the Contract.

9.3.1.4 The Purchaser shall be sole judge in above regard.

9.3.1.5 Apart from the performance security(ies) to be furnished as per Clause GCC 9.3.1 above, additional performance securities, as specified in the Bidding Documents, shall be arranged and furnished by the Supplier at any time after the Notification of Award. The submission of these performance securities to the Purchaser shall, however, be one of the conditions precedent for release of payment (other than Initial/Mobilisation advance) due against such equipment/ works for which the said performance security is required to be submitted.

9.3.2 The performance security shall be in either of the form:

- i. Unconditional Bank Guarantee (in original) in favor of SJVN Arun-3 Power Development Company Pvt. Ltd. from any "A" class Bank in Nepal for the amounts expressed in Nepalese Rupees (NPR). The Bank Guarantees in equivalent INR amount shall be acceptable only if these are issued by a Scheduled Bank of India duly counter guaranteed by any A class bank in Nepal attached hereto in the Section VI - Sample Forms and Procedures.

Bank Guarantee shall be in the format provided in tender document (**Section-VI, Volume-I, Sample forms and Procedures**)

or

- ii. FDR in original (issued by a "A" Class Nepalese Bank/Scheduled Bank of India shall only be acceptable) duly pledged in favour of SJVN Arun-3 Power Development Company Pvt. Ltd.

or



iii. Manager's cheque **in original** (issued by a "A" Class Nepalese Bank shall only be acceptable) in favour of SJVN Arun-3 Power Development Company Pvt. Ltd. payable at Khandbari.

or

iv. Alternatively, performance security may also be submitted/transferred directly in the following account of SJVN Arun-3 Power Development Company Pvt. Ltd.

NPR Account Details:

Everest Bank Limited

Name: SJVN Arun-3 Power Development Company Pvt. Ltd.

Acc. No. 00800105200477

Swift Code: EVBLNPKA

9.3.3 Reduction in the security pro rata to the Contract Price of any part of the Facilities is not admissible.

9.3.4 Deleted

9.4 Issuing Banks

The Bank Guarantee for Advance Payment Security and Performance Security are to be provided by the Supplier, which should be issued by any "A" class Bank in Nepal for the amounts expressed in Nepalese Rupees (NPR). The Bank Guarantees in equivalent INR amount shall be acceptable only if these are issued by a Scheduled Bank of India duly counter guaranteed by any A class bank in Nepal attached hereto in the Section VI - Sample Forms and Procedures.

10. Taxes and Duties

10.1 For CIP Entry Border Point Contract, the Supplier shall be entirely responsible for payment of all taxes, stamp duties, licence fees and other such levies imposed out-side Nepal.

In case of Contract for domestic (i.e. from within Nepal) supplies and services, the Supplier shall be entirely responsible for payment of all taxes, duties, licence fees and other such levies legally payable/incurred until delivery of the contracted supplies to the Purchaser.

If it is statutory requirement to make deductions towards such taxes and duties or any other applicable taxes and duties, the same shall be made by the Purchaser and a certificate for the same shall be issued to the Supplier.

10.2 The Supplier shall be solely responsible for the taxes that may be levied on the Supplier's persons or on earnings of any of his employees and shall hold the Purchaser indemnified and harmless against any claims that may be made against the Purchaser. The Purchaser does not take any responsibility



whatsoever regarding taxes under Income Tax Act of Nepal, for the Supplier or his personnel. If it is obligatory under the provisions of the Income Tax Act, deduction of Income Tax at source shall be made by the Purchaser.

10.3 For CIP Border Point Contract:

In case of Supply of Goods & Services from abroad, taxes & duties shall be as follows:

- (i) any Customs duties/Bhansar or levies or other taxes levied by the Government of Nepal or any local authority in Nepal on the goods and materials covered in the Contract to be imported into Nepal against Purchaser's Import License and which will become the property of the Purchaser under the Contract, shall be to the Supplier's account and shall be paid directly by the Supplier to Government of Nepal or concerned authorities. The Supplier shall submit all the requisite documents to enable the Purchaser to obtain the concessional rate of customs and import duties (if applicable). Any additional liabilities of custom and import duties or penalty thereon, due to discrepancy in the said documents or any other lapse of the Supplier shall be to the account of the Supplier. Supplier has to bear all the taxes and duties applicable on the Goods supplied from Abroad.

In terms of Project Development Agreement signed between Government of Nepal (GoN) and Purchaser on 24.11.2014, the GoN shall exempt import of cement, iron and steel products from payment of customs duty, subject to compliance of norms of Investment Board of Nepal (IBN). The amount of exemption shall be limited to 50% of the rate of custom duty prevailing as on the date of PDA or the actual rate of custom duty, whichever is lower. The Supplier shall take all steps necessary for obtaining the above exemption and coordinate with concerned authorities of GoN. The Purchaser shall not be liable if Supplier fails to obtain such exemptions from GoN.

In addition to above bidders are requested to consider exemptions as per Hydro Development Policy of Nepal 2001 which is available at www.doed.gov.np.

For local supplies:

In respect of Supply of Goods from within Nepal to the Purchaser by the Supplier, the EXW price is inclusive of all cost as well as duties and tax (ex. custom duties & levies, duties, etc.) paid or payable on the Goods or its components, raw materials and any other items used for their consumption incorporated or to be incorporated in the Goods. Supplier has to bear all the taxes and duties applicable on the Goods supplied from within Nepal.



Type test charges for type tests to be conducted in Nepal, if applicable, is inclusive of all the applicable taxes and duties. Supplier has to bear all the taxes and duties applicable on the Type Test charges.

- 10.4 Further, the price for supply of services from within Nepal for ex. Port handling and customs clearance, Supervision Charges (if applicable), Inland transportation, In-transit Insurance and loading etc, are inclusive of all the taxes and duties. Supplier has to bear all the taxes and duties applicable on all the services.
- 10.5 Purchaser would not bear any liability on account of any taxes duties, levies applicable on Supply of Goods and Supply of Services Contracts.
- 10.6 Purchaser shall, deduct taxes at source as per the applicable laws/rules, if any, and issue Tax Deduction at Source (TDS) Certificate to the Supplier.
- 10.7 Foreign Supplier to ensure PAN/VAT/Company registration of their firm in Nepal as per prevailing acts in Nepal after award of work, if applicable.
- 10.8 The Supplier shall comply with all tax laws in force in Nepal. The Supplier shall indemnify and hold harmless the Purchaser from and against any and all liabilities, interest, damages, claims, fines, penalties and expenses of whatever nature arising or resulting from the violation of such tax laws by the Supplier or its personnel, including the Subcontractors and their personnel.
- 10.9 For the purpose of the Contract, it is agreed that the Contract Price specified in Article 2(Contract Price and Terms of Payment) of the Contract Agreement is based on the taxes, duties, levies and charges prevailing at the date seven (07) days prior to the last date of bid submission (hereinafter called "Tax" in this GCC Sub-clause 10.9). If any rates of Tax are increased or decreased, a new Tax is introduced, an existing Tax is abolished, or any change in interpretation except for classification related purpose or application of any Tax occurs in the course of the performance of the Contract, which was or will be assessed on the Supplier in connection with performance of the Contract, an equitable adjustment of the Contract price shall be made to fully take into account any such change by addition to the Contract price or deduction there from, as the case may be, in accordance with GCC Clause 29 (Changes in Laws and Regulations) hereof. These adjustments shall be applicable for all transactions between the Supplier and the Purchaser for supply of goods and services under the Contract but shall not be applicable on procurement of raw materials, intermediary components etc. and on account of variation in taxes, duties & levies applicable locally.

In respect of raw materials, intermediary components etc., the taxes, duties &



levies applicable locally, neither the Purchaser nor the Supplier shall be entitled to any claim arising due to increase or decrease in the rate of Tax, introduction of a new Tax or abolition of an existing Tax in the course of the performance of the Contract.

D. Intellectual Property

11. Copy Right

11.1 The copyright in all drawings, documents and other materials containing data and information furnished to the Purchaser by the Supplier herein shall remain vested in the Supplier or, if they are furnished to the Purchaser directly or through the Supplier by any third party, including supplies of materials, the copyright in such materials shall remain vested in such third party.

11.2 The Purchaser shall however be free to reproduce all drawings, documents and other material furnished to the Purchaser for the purpose of the Contract including, if required, for operation and maintenance.

11.3 The copyright in all drawings, documents and other materials containing data and information furnished to the Supplier by the Purchaser herein shall remain vested in the Purchaser.

12. Confidential Information

12.1 The Purchaser and the Supplier shall keep confidential and shall not, without the written consent of the other party hereto, divulge to any third party any documents, data or other information furnished directly or indirectly by the other party hereto in connection with the Contract, whether such information has been furnished prior to, during or following termination of the Contract. Notwithstanding the above, the Supplier may furnish to its Subcontractor(s) such documents, data and other information it receives from the Purchaser to the extent required for the Subcontractor(s) to perform its work under the Contract, in which event the Supplier shall obtain from such Subcontractor(s) an undertaking of confidentiality similar to that imposed on the Supplier under this GCC Clause 12.

12.2 The Purchaser shall not use such documents, data and other information received from the Supplier for any purpose unrelated to the contract. Similarly, the Supplier shall not use such documents, data and other information received from the Purchaser for any purpose other than the performance of the Contract.

12.3 The obligation of a party under GCC Sub-Clauses 12.1 and 12.2 above, however, shall not apply to that information which



- (a) now or hereafter enters the public domain through no fault of that party
- (b) can be proven to have been possessed by that party at the time of disclosure and which was not previously obtained, directly or indirectly, from the other party hereto
- (c) otherwise lawfully becomes available to that party from a third party that has no obligation of confidentiality.

12.4 The above provisions of this GCC Clause 12 shall not in any way modify any undertaking of confidentiality given by either of the parties hereto prior to the date of the Contract in respect of the Facilities or any part thereof.

12.5 The provisions of this GCC Clause 12 shall survive termination, for whatever reason, of the Contract.

E. Execution of the Contract

13. Representatives

13.1 If the Project Manager is not named in the Contract, then within fourteen (14) days of the Effective Date, the Purchaser shall appoint and notify the Supplier in writing of the name of the Project Manager. The Purchaser may from time to time appoint some other person as the project Manager in place of the person previously so appointed, and shall give a notice of the name of such other person to the Supplier without delay. The Purchaser shall take all reasonable care to see that no such appointment is made at such a time or in such a manner as to impede the progress of work on the Facilities. The Project Manager shall represent and act for the Purchaser at all times during the currency of the Contract. All notices, instructions, orders, certificates, approvals and all other communications under the Contract shall be given by the Project Manager, except as herein otherwise provided.

All notices, instructions, information and other communications given by the Supplier to the Purchaser under the Contract shall be given to the Project Manager, except as herein otherwise provided.

13.2 Supplier's Representative

13.2.1 If the Supplier's Representative is not named in the Contract, then within fourteen (14) days of the Effective Date, the Supplier shall appoint the Supplier's Representative and shall request the Purchaser in writing to approve the person so appointed. If the Purchaser makes no objection to the appointment within fourteen (14) days, the Supplier's Representative shall be deemed to have been approved. If the Purchaser objects to the appointment within fourteen (14) days giving the reason therefor, then the Supplier shall appoint a replacement within fourteen (14) days of such



objection, and the foregoing provisions of this GCC Sub-Clause 13.2.1 shall apply thereto.

- 13.2.2 The Supplier's Representative shall represent and act for the Supplier at all times during the currency of the Contract and shall give to the Project Manager all the Supplier's notices, instructions, information and all other communications under the Contract. All notices, instructions, information and all other communications given by the Purchaser or the Project Manager to the Supplier under the Contract shall be given to the Supplier's Representative or, in its absence, its deputy, except as herein otherwise provided. The Supplier shall not revoke the appointment of the Supplier's Representative without the Purchaser's prior written consent, which shall not be unreasonably withheld. If the Purchaser consents thereto, the Supplier shall appoint some other person as the Supplier's Representative, pursuant to the procedure set out in GCC Sub-Clause 13.2.1.
- 13.2.3 The Supplier's Representative may, subject to the approval of the Purchaser (which shall not be unreasonably withheld), at any time delegate to any person any of the powers, functions and authorities vested in him or her. Any such delegation may be revoked at any time. Any such delegation or revocation shall be subject to a prior notice signed by the Supplier's Representative, and shall specify the powers, functions and authorities thereby delegated or revoked. No such delegation or revocation shall take effect unless and until a copy thereof has been delivered to the Purchaser and the Project Manager. Any act or exercise by any person of powers, functions and authorities so delegated to him or her in accordance with this GCC Sub-Clause 13.2.3 shall be deemed to be an act or exercise by the Supplier's Representative.
- 13.2.4 Notwithstanding anything stated in GCC Sub-Clause 13.1 and 13.2.1 above, for the purpose of execution of Contract, the Purchaser and the Supplier shall finalize and agree to a Contract Co-ordination Procedure and all the communication under the Contract shall be in accordance with such Contract Coordination Procedure.
- 13.2.5 From the commencement of installation of the Goods at the Site until Commissioning, the Supplier's Representative shall appoint all technical personnel for supervision of installation and operation of the Goods. The supervisory personnel shall supervise all work done at the Site by the Supplier and shall be present at the Site through-out normal working hours except when on leave, sick or absent for reasons connected with the proper performance of the Contract. Whenever a supervisory personnel is absent from the Site, a suitable person shall be appointed to act as his or her deputy.
- 13.2.6 The Purchaser may by notice to the Supplier object to any representative or person employed by the Supplier in the execution of the Contract who, in the



reasonable opinion of the Purchaser, may behave inappropriately, may be incompetent or negligent, or may commit a serious breach of the Site regulations provided under GCC Sub-Clause 18.3. The Purchaser shall provide evidence of the same, whereupon the Supplier shall remove such person from the Facilities.

13.2.7 If any representative or person employed by the Supplier is removed in accordance with GCC Sub-Clause 13.2.5, the Supplier shall, where required, promptly appoint a replacement.

14. Work Program

14.1 Supplier's Organization

The Supplier shall supply to the Purchaser and the Project Manager a chart showing the proposed organization to be established by the Supplier for carrying out supervision work. The chart shall include the identities of the key personnel together with the curricula vitae of such key personnel to be employed within twenty-one (21) days of the Effective Date. The Supplier shall promptly inform the Purchaser and the Project Manager in writing of any revision or alteration of such an organization chart.

14.2 Program of Performance

Within twenty-eight (28) days after the date of Notification of Award, the Supplier shall prepare and submit to the Project Manager a detailed program of performance of the Contract (L2 Network) in the form of the Critical Path Method (CPM), the PERT network, or other internationally used programs and showing the sequence in which it proposes to design, engineering, procurement, manufacture, shop inspection, testing, transport of the Goods, as well as the date by which the Supplier reasonably requires that the Purchaser shall have fulfilled its obligations under the Contract so as to enable the Supplier to execute the Contract in accordance with the program and to achieve Completion of the Goods and Related Services in accordance with the Contract. The program so submitted by the Supplier shall accord with the Delivery Schedule included in Appendix-4 (Delivery Schedule) to the Contract Agreement and any other dates and periods specified in the Contract. The Supplier shall update and revise the program as and when appropriate or when required by the Project Manager, but without modification in the Delivery Schedule under GCC Clause 4 and any extension granted in accordance with GCC Clause 32, and shall submit all such revisions to the Project Manager.

14.3 Progress Report

The Supplier shall monitor progress of all the activities specified in the program referred to in GCC Sub-Clause 14.2 above, and supply a progress report to the Project Manager every month.



The progress report shall be in a form acceptable to the Project Manager and shall indicate: (a) percentage completion achieved compared with the planned percentage completion for each activity; and (b) where any activity is behind the program, giving comments and likely consequences and stating the corrective action being taken.

14.4 Progress of Performance

If at any time the Supplier's actual progress falls behind the program referred to in GCC Sub-Clause 14.2, or it becomes apparent that it will so fall behind, the Supplier shall, at the request of the Purchaser or the Project Manager, prepare and submit to the Project Manager a revised program, taking into account the prevailing circumstances, and shall notify the Project Manager of the steps being taken to expedite progress so as to attain completion of delivery of Goods within the Delivery Schedule under GCC Sub-Clause 4, any extension thereof entitled under GCC Sub-Clause 32.1, or any extended period as may otherwise be agreed upon between the Purchaser and the Supplier.

14.5 Work Procedures

The Contract shall be executed in accordance with the Contract Documents and the procedures given in the section on Sample Forms and Procedures of the Contract Documents.

The Supplier may execute the Contract in accordance with its own standard project execution plans and procedures to the extent that they do not conflict with the provisions contained in the Contract.

15. Subcontracting

- 15.1 The corresponding Appendix (List of Approved Subcontractors) to the Contract Agreement specifies major items of supply or services and a list of approved Subcontractors against each item, including vendors. Insofar as no Subcontractors are listed against any such item, the Supplier shall prepare a list of Subcontractors for such item for inclusion in such list. The Supplier may from time to time propose any addition to or deletion from any such list. The Supplier shall submit any such list or any modification thereto to the Purchaser for its approval in sufficient time so as not to impede the progress of work on the Goods. Such approval by the Purchaser for any of the Subcontractors shall not relieve the Supplier from any of its obligations, duties or responsibilities under the Contract.
- 15.2 The Supplier shall select and employ its Subcontractors for such major items from those listed in the lists referred to in GCC Sub- Clause 15.1.



- 15.3 For items or parts of the Goods not specified in the corresponding Appendix (List of Approved Subcontractors) to the Contract Agreement, the Supplier may employ such Subcontractors as it may select, at its discretion.
- 15.4 The Supplier shall furnish the details of items, components, raw materials, services etc. procured from MSEs and consumed for completion of scope of works under the contract. The details shall be furnished as per the format enclosed at Section VI, Forms & Procedures, Volume-I of the bidding documents at the time of raising bills for payment against the supplies made/works done.

16. Design and Engineering

16.1 Specifications and Drawings

- 16.1.1 The Supplier shall execute the basic and detailed design and the engineering work in compliance with the provisions of the Contract, or where not so specified, in accordance with good engineering practice.

The Supplier shall be responsible for any discrepancies, errors or omissions in the specifications, drawings and other technical documents that it has prepared, whether such specifications, drawings and other documents have been approved by the Project Manager or not, provided that such discrepancies, errors or omissions are not because of inaccurate information furnished in writing to the Supplier by or on behalf of the Purchaser.

- 16.1.2 The Supplier shall be entitled to disclaim responsibility for any design, data, drawing, specification or other document, or any modification thereof provided or designated by or on behalf of the Purchaser, by giving a notice of such disclaimer to the Project Manager.

16.2 Codes and Standards

Wherever references are made in the Contract to codes and standards in accordance with which the Contract shall be executed, the edition or the revised version of such codes and standards current at the date twenty-eight (28) days prior to date of bid submission shall apply unless otherwise specified. During Contract execution, any changes in such codes and standards shall be applied after approval by the Purchaser and shall be treated in accordance with GCC Clause 31.

16.3 Approval/Review of Technical Documents by Project Manager

- 16.3.1 The Supplier shall prepare (or cause its Subcontractors to prepare) and furnish to the Project Manager the documents listed in Appendix-6 (List of



Documents for Approval or Review) to the Contract Agreement for its approval or review as specified and as in accordance with the requirements of GCC Sub-Clause 14.2 (Program of Performance).

Any part of the Goods covered by or related to the documents to be approved by the Project Manager shall be executed only after the Project Manager's approval thereof.

GCC Sub-Clauses 16.3.2 through 16.3.7 shall apply to those documents requiring the Project Manager's approval, but not to those furnished to the Project Manager for its review only.

- 16.3.2 Within twenty one (21) days after receipt by the Project Manager of any document requiring the Project Manager's approval in accordance with GCC Sub-Clause 16.3.1, the Project Manager shall either return one copy thereof to the Supplier with its approval endorsed thereon or shall notify the Supplier in writing of its disapproval thereof and the reasons therefor and the modifications that the Project Manager proposes.
- 16.3.3 The Project Manager shall not disapprove any document, except on the grounds that the document does not comply with some specified provision of the Contract or that it is contrary to good engineering practice.
- 16.3.4 If the Project Manager disapproves the document, the Supplier shall modify the document and resubmit it for the Project Manager's approval in accordance with GCC Sub-Clause 16.3.2. If the Project Manager approves the document subject to modification(s), the Supplier shall make the required modification(s), and upon resubmission with the required modifications the document shall be deemed to have been approved.

The procedure for submission of the documents by the Supplier and their approval by the Project Manager shall be discussed and finalized with the Supplier.

- 16.3.5 If any dispute or difference occurs between the Purchaser and the Supplier in connection with or arising out of the disapproval by the Project Manager of any document and/or any modification(s) thereto that cannot be settled between the parties within a reasonable period, then such dispute or difference may be referred to an Arbitrator for determination in accordance with GCC Sub-Clause 36 hereof. If such dispute or difference is referred to an Arbitrator, the Project Manager shall give instructions as to whether and if so, how, performance of the Contract is to proceed. The Supplier shall proceed with the Contract in accordance with the Project Manager's instructions, provided that if the Arbitrator upholds the Supplier's view on the dispute and if the Purchaser has not given notice under GCC Sub-Clause 36 hereof, then the Supplier shall be



reimbursed by the Purchaser for any additional costs incurred by reason of such instructions and shall be relieved of such responsibility or liability in connection with the dispute and the execution of the instructions as the Arbitrator shall decide, and the Delivery Schedule shall be extended accordingly.

- 16.3.6 The Project Manager's approval, with or without modification of the document furnished by the Supplier, shall not relieve the Supplier of any responsibility or liability imposed upon it by any provisions of the Contract except to the extent that any subsequent failure results from modifications required by the Project Manager.
- 16.3.7 The Supplier shall not depart from any approved document unless the Supplier has first submitted to the Project Manager an amended document and obtained the Project Manager's approval thereof, pursuant to the provisions of this GCC Sub-Clause 16.3. If the Project Manager requests any change in any already approved document and/or in any document based thereon, the provisions of GCC Clause 31 shall apply to such request.

17. Goods & Related Services

- 17.1 Subject to GCC Sub-Clause 10.2, the Supplier shall manufacture or procure and transport all the Goods in an expeditious and orderly manner to the Site.
- 17.2 Transportation
- 17.2.1 The Supplier shall at its own risk and expense transport all the Goods to the Site by the mode of transport that the Supplier judges most suitable under all the circumstances.
- 17.2.2 Unless otherwise provided in the Contract, the Supplier shall be entitled to select any safe mode of transport operated by any person to carry the Goods. In case of transportation by road, the Supplier shall transport all the goods only through registered common carriers in line with requisite Act/rule/notification including amendment thereof.
- 17.2.3 Upon dispatch of each shipment, the Supplier shall notify the Purchaser by telex, facsimile or Electronic Data Interchange (EDI) of the description of the Goods, the point and means of dispatch, and the estimated time and point of arrival in the country where the Site is located, if applicable, and at the Site. The Supplier shall furnish the Purchaser with relevant shipping documents to be agreed upon between the parties.
- 17.2.4 The Supplier shall be responsible for obtaining, if necessary, approvals from the authorities for transportation of the Goods to the Site. The Purchaser shall use its best endeavors in a timely and expeditious manner to assist the

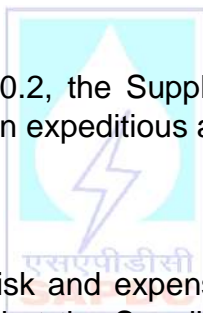

Supplier in obtaining such approvals, if requested by the Supplier. The Supplier shall indemnify and hold harmless the Purchaser from and against any claim for damage to roads, bridges or any other traffic facilities that may be caused by the transport of the Goods to the Site.

17.2.5 Customs Clearance

The Supplier shall, at its own expense, handle all imported Goods and Supplier's Equipment at the point(s) of import and shall handle any formalities for customs clearance including liabilities for port charges if any, provided that if applicable laws or regulations require any application or act to be made by or in the name of the Purchaser, the Purchaser shall take all necessary steps to comply with such laws or regulations.

17.3 Delivery and Documents

17.3.1 Delivery Documents

Upon shipment, the Supplier shall notify the Purchaser with full details of the dispatch and shall furnish the documents as specified in the corresponding Appendix - 1 (Terms and Procedures of Payment) to the Contract Agreement

17.3.2 Packing

17.3.2.1 The Supplier shall provide such packing of the Goods as it is required to prevent their damage or deterioration during transit to their final destination as indicated in the Contract. The packing shall be sufficient to withstand, without limitation, rough handling during transit and exposure to extreme temperatures, salt and precipitation during transit and open storage. Packing case size and weights shall take into consideration, where appropriate, the remoteness of the Goods final destination and the absence of heavy handling facilities at all points in transit.

17.3.2.1 The packing, marking and documentation within and outside the packages shall comply strictly with such special requirements as shall be expressly provided for in the Contract and, subject to any subsequent instruction ordered by the Purchaser consistent with the requirements of the Contract.

18. Supervision of Installation

18.1 The Supplier shall give or provide all necessary superintendence during the installation of the Goods, and the supervisory personnel or its deputy shall be constantly on the Site to provide full-time superintendence of the installation. The Supplier shall provide and employ only technical personnel who are skilled and experienced in their respective callings and supervisory staff who are competent to adequately supervise the work at hand.

19. Test and Inspection



- 19.1 The Supplier shall at its own expense carry out at the place of manufacture and/or on the Site all such tests and/or inspections of the Goods and Related Services as are specified in the Contract.
- 19.2 The Purchaser and the Project Manager or their designated representatives shall be entitled to attend the aforesaid test and/or inspection, provided that the Purchaser shall bear all costs and expenses incurred in connection with such attendance including, but not limited to, all traveling and board and lodging expenses.
- 19.3 Whenever the Supplier is ready to carry out any such test and/or inspection, the Supplier shall give four weeks advance notice of such test and/or inspection and of the place and time thereof to the Project Manager. The Supplier shall obtain from any relevant third party or manufacturer any necessary permission or consent to enable the Purchaser and the Project Manager (or their designated representatives) to attend the test and/or inspection. Subject to GCC Sub-Clause 19.3, if test and/or inspection are conducted on the premises of the Supplier or its Subcontractor, all reasonable facilities and assistance, including access to drawings and production data, shall be furnished to the inspectors at no charge to the Purchaser.
- 19.4 The Supplier shall provide the Project Manager with a certified report of the results of any such test and/or inspection.
- If the Purchaser or Project Manager (or their designated representatives) fails to attend the test and/or inspection, or if it is agreed between the parties that such persons shall not do so, then the Supplier may proceed with the test and/or inspection in the absence of such persons, and may provide the Project Manager with a certified report of the results thereof.
- 19.5 The Project Manager may require the Supplier to carry out any test and/or inspection not required by the Contract, provided that the Supplier's reasonable costs and expenses incurred in the carrying out of such test and/or inspection shall be added to the Contract Price. Further, if such test and/or inspection impedes the progress of work on the Goods and/or the Supplier's performance of its other obligations under the Contract, due allowance will be made in respect of the Delivery Schedule and the other obligations so affected.
- 19.6 The Purchaser may reject any Goods or any part thereof that fails to pass any test and/or inspection or do not conform to the Specifications. The Supplier shall either rectify or replace such rejected Goods or part thereof or make alterations necessary to meet the specifications at no cost to the Purchaser, and shall repeat the test and/or inspection upon giving a notice under GCC Sub-Clause 19.3.



- 19.7 If any dispute or difference of opinion shall arise between the parties in connection with or arising out of the test and/or inspection of the Goods or part thereof that cannot be settled between the parties within a reasonable period of time, it may be referred to an Arbitrator for determination in accordance with GCC Sub-Clause 36.
- 19.8 The Supplier shall afford the Purchaser and the Project Manager, at the Purchaser's expense, access at any reasonable time to any place where the Goods are being manufactured, in order to inspect the progress and the manner of manufacture, provided that the Project Manager shall give the Supplier a reasonable prior notice.
- 19.9 The Supplier agrees that neither the execution of a test and/or inspection of Goods or any part thereof, nor the attendance by the Purchaser or the Project Manager, nor the issue of any test certificate pursuant to GCC Sub-Clause 19.4, shall release the Supplier from any other responsibilities under the Contract.

20. Completion

- 20.1 As soon as the delivery of Goods & performance of Related Services, in the opinion of the Supplier, has been completed as specified in the Technical Specifications, the Supplier shall so notify the Purchaser in writing along with the Undertaking for quality and performance of such Goods. The Purchaser after inspection/physical verification shall notify the Supplier of defects and/or deficiencies, if any. The Supplier shall repair, replacement or making good of any defect or of any damage or deficiencies and shall so notify the Purchaser in writing. The Purchaser after inspection/physical verification shall issue to the Supplier an Material Acceptance Certificate in the form of Materials Receipt Certificate (MRC) verifying the date on which the supply of Goods have been completed and accepted. Such certificate shall not relieve the Supplier of any of his obligations which otherwise survive, by the terms and conditions of Contract after issue of such certificate.
- 20.2 As soon as reasonably practicable, within the expected period indicated in GCC Clause 20.3 below, the Purchaser through a Contractor shall use the Goods so supplied for Installation, Precommissioning & Commissioning of the Facilities. In case of Contracts where the supervision is stipulated, the Installation, Precommissioning & Commissioning of the Goods shall be carried out in presence of the Supplier's representatives. The Supplier's representatives shall be responsible for carrying out start-up, initial operation, trial operation and the performance test, as admissible, for which necessary labour and facilities shall be provided by the Purchaser. However, all temporary instrumentation, measuring devices, special tools and tackles etc., if any, required for performing activities under the Contract will be provided by the Supplier.



- 20.2.1 During these stages, if the Project Manager notifies the Supplier of any defects and/or deficiencies, the Supplier shall then correct such defects and/or deficiencies failing which the Purchaser will undertake such completion and deduct the costs thereof from any monies owing to the Supplier.
- 20.3 The expected Precommissioning/ Commissioning schedule of the Facilities wherein the Goods under the Contract are to be installed is indicated in SCC. In the event the Purchaser/Contractor is unable to proceed with the Precommissioning/ Commissioning of the Facilities, within the expected Precommissioning/ Commissioning schedule, for reasons not attributable to the Supplier, the following provisions shall apply:
- a) The performance securities and any other securities relevant to the circumstances shall be extended by the Supplier from time to time as may be required by the Purchaser, as per the following:
- (i) upto six months beyond the initial period for which performance securities are to be otherwise kept valid as per GCC Clause 9.3.1.
 - (ii) upto twelve months beyond the period mentioned in para (i) above for which the expenses, if any, payable by the Supplier to the Bankers toward the same shall be reimbursed to the Supplier by the Purchaser against documentary evidence.
 - (iii) upto a mutually agreed period between the Purchaser and the Supplier, beyond the period mentioned in para (ii) above, failing which the Goods shall be deemed to be Taken Over by the Purchaser upon expiry of the period mentioned in para (ii) above and the mutually agreed period, if any, as per this para and the Defect Liability Period as per GCC Clause 22 shall be governed from the date of deemed Taking Over. The expenses towards extension, if any, under this para, payable by the Supplier to the Bankers toward the same shall be reimbursed to the Supplier by the Purchaser against documentary evidence.

Notwithstanding the extension of securities as per the aforesaid provisions, in the event of Precommissioning/ Commissioning of the Facilities within the extended period as aforesaid, the validity period of the securities shall be regulated as per the provisions of GCC Clause 9.3.1.

- b) In case of Supply cum Supervision Contracts, payments due to the

Supplier in accordance with the provisions specified in Appendix I (Terms and Procedures of Payment) to the Contract Agreement, which would have not been payable in normal circumstances due to non-completion of the subject activities, shall be released to the Supplier against submission of a security in the form of a bank guarantee of equivalent amount acceptable to the Purchaser, and which shall become null and void when the Facilities are commissioned. The expenses toward the above security shall be reimbursed to the Supplier by the Purchaser.

20.4 Taking Over

20.4.1 Upon successful Commissioning of the Facilities, the Project Manager shall within twenty-one (21) days issue an Taking Over Certificate as a proof of the final acceptance of the Goods. Such certificate shall not relieve the Supplier of any of his obligations which otherwise survive, by the terms and conditions of Contract after issue of such certificate.

20.4.2 If within twenty one (21) days after Commissioning of the Facilities, the Project Manager fails to issue the Taking Over Certificate or fails to inform the Supplier in writing of the justifiable reasons why the Project Manager has not issued the Taking Over Certificate, the Goods or the relevant part thereof shall be deemed to have been accepted as at the date of the Commissioning of the Facilities.

F. Guarantees and Liabilities

21. Completion Time Guarantee

21.1 The Supplier guarantees that it shall attain delivery of Goods (or a part for which a separate time schedule is specified in the SCC) at final destination site with the time specified in the SCC pursuant to GCC Clause 4, or within such extended time to which the Supplier shall be entitled under GCC Clause 31 hereof.

21.2 If the Supplier fails to comply with the Delivery Schedule in accordance with Clause GCC 21 for the whole of the goods, (or a part for which a separate time schedule is agreed) then the Supplier shall pay to the Purchaser a sum equivalent to 0.11% (zero point one one percent) and part there of the Contract Price of undelivered Goods or the Services as liquidated damages(LD) for such default and not as a penalty, without prejudice to the Purchaser's other remedies under the Contract, for each day of delay until actual delivery or performance subject to the limit of ten percent (10%) of Contract Price.

The parties agree that the sum specified above is not a penalty but a genuine pre-estimate of the loss/damage which will be suffered by the Employer for default on the part of the Contractor and said amount will be



payable without proof of actual loss or damage caused by such default.

The Purchaser may, without prejudice to any other method of recovery, deduct the amount of such damages from any monies due or to become due to the Supplier. The payment or deduction of such damages shall not relieve the Supplier from his obligation to complete the Works, or from any other of his obligations and liabilities under the Contract.

LD on individual mile stone or in totality shall not exceed ten percent (10%) of Contract Price.

21.3 No bonus will be given for earlier completion of the delivery of Goods.

22. Defect Liability

22.1 The Defect Liability Period shall remain valid for a period of twelve (12) months from the date of commissioning of Goods or Eighteen (18) months from the date of completion of delivery at final destination site(s) whichever is earlier.

22.2 The Supplier warrants that all the Goods supplied under the Contract shall comply strictly with the Contract, shall be first class in every particular and shall be free from defects. The Supplier further warrants that all equipments, materials and supplies furnished by the Supplier or its sub-contractors for the purpose of the Goods are new, merchantable of the most suitable grade, and fit for their intended purposes. The Supplier further warrants that the services to be carried out under this contract will conform with generally accepted professional standards and engineering principles.

22.3 Subject to GCC Sub-Clause 22.2, the Supplier further warrants that the Goods shall be free from defects arising from any act or omission of the Supplier or arising from design, materials, and workmanship, under normal use in the conditions prevailing in the country of final destination.

22.4 The Purchaser shall give Notice to the Supplier stating the nature of any such defects together with all available evidence thereof, promptly following the discovery thereof. The Purchaser shall afford all reasonable opportunity for the Supplier to inspect such defects.

22.5 Upon receipt of such notice, the Supplier shall, within 30 days, expeditiously repair or replace the defective Goods or parts thereof, at no cost to the Purchaser. The Supplier shall take over the replaced parts/goods at the time of their replacement. No claim whatsoever shall lie on the Purchaser for the replaced parts/goods thereafter. In the event of any correction of defects or replacement of defective goods during the Defect Liability Period, the Defect Liability Period for the corrected/replaced goods shall be extended to a further period of 12 months.



- 22.6 If having been notified, the Supplier fails to remedy the defect within 30 days, the Purchaser may proceed to take within a reasonable period such remedial action as may be necessary, at the Supplier's risk and expense and without prejudice to any other rights which the Purchaser may have against the Supplier under the Contract.
- 22.7 At the end of the Defect Liability Period, the Supplier's Liability ceases except for latent defects. The Supplier's liability for latent defects warranty shall be limited to period of ten (10) years from the end of Defect Liability Period. For the purpose of this clause, the latent defects shall be the defects inherently lying within the material or arising out of design deficiency, which do not manifest themselves during the Defect Liability Period defined in this GCC Clause 22, but later.

23. **Equipment Performance Guarantees**

Deleted

24. **Patent Indemnity**

- 24.1 The Supplier shall, subject to the Purchaser's compliance with GCC Sub-Clause 24.2, indemnify and hold harmless the Purchaser and its employees and officers from and against any and all suits, actions or administrative proceedings, claims, demands, losses, damages, costs, and expenses of whatsoever nature, including attorney's fees and expenses, which the Purchaser may suffer as a result of any infringement or alleged infringement of any patent, utility model, registered design, trademark, copyright or other intellectual property right registered or otherwise existing at the date of the Contract by reason of: (a) the installation of the Goods by the Supplier or the use of the Goods in the country where the Site is located; and (b) the sale of the products produced by the Goods in any country.

Such indemnity shall not cover any use of the Goods or any part thereof other than for the purpose indicated by or to be reasonably inferred from the Contract, any infringement resulting from the use of the Goods or any part thereof, or any products produced thereby in association or combination with any other equipment, plant or materials not supplied by the Supplier, pursuant to the Contract Agreement.

- 24.2 If any proceedings are brought or any claim is made against the Purchaser arising out of the matters referred to in GCC Sub-Clause 24.1, the Purchaser shall promptly give the Supplier a notice thereof, and the Supplier may at its own expense and in the Purchaser's name conduct such proceedings or claim



and any negotiations for the settlement of any such proceedings or claim. If the Supplier fails to notify the Purchaser within twenty-eight (28) days after receipt of such notice that it intends to conduct any such proceedings or claim, then the Purchaser shall be free to conduct the same on its own behalf. Unless the Supplier has so failed to notify the Purchaser within the twenty-eight (28) day period, the Purchaser shall make no admission that may be prejudicial to the defense of any such proceedings or claim.

The Purchaser shall, at the Supplier's request, afford all available assistance to the Supplier in conducting such proceedings or claim, and shall be reimbursed by the Supplier for all reasonable expenses incurred in so doing.

- 24.3 The Purchaser shall indemnify and hold harmless the Supplier and its employees, officers and Subcontractors from and against any and all suits, actions or administrative proceedings, claims, demands, losses, damages, costs, and expenses of whatsoever nature, including attorney's fees and expenses, which the Supplier may suffer as a result of any infringement or alleged infringement of any patent, utility model, registered design, trademark, copyright or other intellectual property right registered or otherwise existing at the date of the Contract arising out of or in connection with any design, data, drawing, specification, or other documents or materials provided or designed by or on behalf of the Purchaser.

25. Limitation of Liability

- 25.1 Except in cases of gross negligence or willful misconduct,

- (a) The Supplier and the Purchaser shall not be liable to each other for any indirect or consequential loss or damage, loss of use, loss of production, or loss of profits or interest costs, provided that this exclusion shall not apply to any obligation of the Supplier to pay liquidated damages to the Purchaser and
- (b) the aggregate liability of the Supplier to the Purchaser, whether under the Contract, in tort or otherwise, shall not exceed the total Contract Price, provided that this limitation shall not apply to the cost of repairing or replacing defective goods, or to any obligation of the Supplier to indemnify the Purchaser with respect to patent infringement.

G. Risk Distribution

26. Transfer of Ownership

- 26.1 Ownership of the Goods to be imported into Nepal shall be transferred to the Purchaser upon loading on to the mode of transport to be used to convey the



Goods from the country of origin to that country and upon endorsement of the dispatch documents in favour of the Purchaser.

- 26.2 Ownership of the Goods procured in Nepal, shall be transferred to the Purchaser upon loading on to the mode of transport to be used to carry the Goods from the works/warehouse/ any other place where the Supplier wishes to supply the goods to the site and upon endorsement of the despatch documents in favour of the Purchaser.
- 26.3 Ownership of the Supplier"s Equipment used by the Supplier and its Subcontractors in connection with the Contract shall remain with the Supplier or its Subcontractors.
- 26.4 Notwithstanding the transfer of ownership of the Goods, the Supplier shall continue to be responsible for the quality and performance of such Goods and for their compliance with the specifications until „Taking Over“ and the fulfillment of warranty obligations under the Contract. The transfer of ownership shall not relieve the Supplier from the responsibility for all risks of loss or damage to the Goods as specified under GCC 28 (Insurance).
27. **Loss of or Damage to Property; Accident or Injury to Workers; Indemnification**
- 27.1 The Supplier shall indemnify and hold harmless the Purchaser and its employees and officers from and against any and all suits, actions or administrative proceedings, claims, demands, losses, damages, costs, and expenses of whatsoever nature, including attorney"s fees and expenses, in respect of the death or injury of any person or loss of or damage to any property (other than the Facilities whether accepted or not), arising in connection with the supply of the Goods and by reason of the negligence of the Supplier or its Subcontractors, or their employees, officers or agents, except any injury, death or property damage caused by the negligence of the Purchaser, its contractors, employees, officers or agents.
- 27.2 If any proceedings are brought or any claim is made against the Purchaser that might subject the Supplier to liability under GCC Sub- Clause 27.1, the Purchaser shall promptly give the Supplier a notice thereof and the Supplier may at its own expense and in the Purchaser"s name conduct such proceedings or claim and any negotiations for the settlement of any such proceedings or claim.
- 27.3 If the Supplier fails to notify the Purchaser within twenty-eight (28) days after receipt of such notice that it intends to conduct any such proceedings or claim, then the Purchaser shall be free to conduct the same on its own behalf. Unless



the Supplier has so failed to notify the Purchaser within the twenty-eight (28) day period, the Purchaser shall make no admission that may be prejudicial to the defense of any such proceedings or claim.

The Purchaser shall, at the Supplier's request, afford all available assistance to the Supplier in conducting such proceedings or claim, and shall be reimbursed by the Supplier for all reasonable expenses incurred in so doing.

- 27.4 Notwithstanding anything in this Contract to the contrary, it is agreed that neither the Supplier nor the Purchaser shall be liable to the other party for loss of production, loss of profit, loss of use or any other indirect or consequential damages.

28. Insurance

- 28.1 To the extent specified in the corresponding Appendix-3 (Insurance Requirements) to the Contract Agreement, the Supplier shall at its expense take out and maintain in effect, or cause to be taken out and maintained in effect, during the performance of the Contract, the insurances set forth below in the sums and with the deductibles and other conditions specified in the said Appendix. The identity of the insurers and the form of the policies shall be subject to the approval of the Purchaser, who should not unreasonably withhold such approval.

- (a) Marine Cargo Policy/Transit Insurance Policy:

- (I)(i) Marine Cargo policy for imported equipment

The Supplier shall take the Marine Cargo Policy for Goods to be supplied from abroad wherein export/import including inland transit is involved for the movement of the Goods. The policy shall cover movement of Goods from the manufacturer's works to the project's warehouse at final destination site. The policy shall cover all risk for loss or damage that may occur during transit of Goods from the Supplier's/Sub-supplier's works or stores until arrival at project's warehouse/ store at final destination. The perils required to be covered under the insurance shall include, but not be limited to, fire and allied risks, miscellaneous accidents, workman compensation risks, loss or damage in transit, theft, pilferage, riots and strikes and malicious damages, civil commotion, weather conditions, accidents of all kinds, war risks (as far as insurable) etc. Institute Cargo Clause (ICC) „A“ along with war & Strike Riots & Civil Commotion (SRCC) cover shall be taken.

- (I)(ii) Transit Insurance Policy for indigenous equipment



Similarly, Transit Insurance Policy shall be taken wherein only inland transit is involved for the movement of Goods supplied from within Nepal. The policy shall cover movement of Goods from the manufacturer's works to the project's warehouse at final destination site. The perils required to be covered under the insurance shall include, but not be limited to, fire and allied risks, miscellaneous accidents, workman compensation risks, loss or damage in transit, theft, pilferage, riots and strikes and malicious damages, civil commotion, weather conditions, accidents of all kinds, war risks (as far as insurable) etc. Inland Transit Clause (ITC) "A" alongwith Strike Riots & Civil Commotion (SRCC) extension cover shall be taken.

- (II) If during the execution of Contract, the Purchaser requests the Supplier to take any other add-on cover(s)/ supplementary cover(s) in aforesaid insurance, in such a case, the Supplier shall promptly take such add-on cover(s)/ supplementary cover(s) and the charges towards such premium for such add-on cover(s)/ supplementary cover(s) shall be reimbursed to the Supplier on submission documentary evidence of payment to the Insurance company. Therefore, charges towards premium for such add-on cover(s)/ supplementary cover(s) are not included in the Contract Price.
- (III) The Supplier shall take the policy in the joint names of Purchaser and the Supplier. The policy shall indicate the Purchaser as the beneficiary. However, if the Supplier is having an open policy for its line of business, it should obtain an endorsement of the open cover policy from the insurance company indicating that the dispatches against this Contract are duly covered under its open policy and include the name of the Purchaser as jointly Insured in the endorsements to the open policy.
- (IV) The scope of such insurance shall be adequate to cover the replacement/reinstatement cost or 120% of CIF/Ex- Works cost whichever is higher, of the Goods for all risks upto and including delivery of Goods on final destination site basis and shall also cover customs duty on merit rate, inland transportation and other costs till the Goods are delivered at site. The insurance policies to be taken should be on replacement value basis and/or incorporating escalation clause. The Purchaser shall recover the payments made except advance and the balance amount shall be released to the Supplier. Notwithstanding the extent of the insurance cover and the amount of claim available from the underwriters, the Supplier shall be liable to make good the full replacement/rectification of all Goods/Materials and to ensure their availability as per project requirements. The Supplier shall be authorized to deal directly with the insurance company.



- 28.2 The Purchaser shall be named as co-insured under all insurance policies taken out by the Supplier pursuant to GCC Sub-Clause 28.1. All insurer's rights of subrogation against such co-insureds for losses or claims arising out of the performance of the Contract shall be waived under such policies.
- 28.3 It will be the responsibility of the Supplier to lodge, pursue and settle all claims with the insurance company in case of any damage, loss, theft, pilferage or fire during execution of Contract and Purchaser shall be kept informed about it. The Supplier shall replace the lost/damaged materials promptly irrespective of the settlement of the claims by the underwriters and ensure that the work progress is as per agreed schedules. The losses, if any, in such replacement will have to be borne by the Supplier.

29. Change in Laws and Regulations

- 29.1 If, after the date seven (07) days prior to the date of Bid Opening, any law, regulation, ordinance, order or by-law having the force of law is enacted, promulgated, abrogated or changed in Nepal (which shall be deemed to include any change in interpretation or application by the competent authorities) that subsequently affects the costs and expenses of the Supplier and/or the Delivery Schedule, the Contract Price shall be correspondingly increased or decreased, and/or the Delivery Schedule shall be reasonably adjusted to the extent that the Supplier has thereby been affected in the performance of any of its obligations under the Contract. These adjustments shall be applicable for all transactions between the Purchaser and the Supplier for supply of goods and services under the Contract but shall not be applicable on procurement of raw materials, intermediary components etc. by the Supplier for which the Purchaser shall be the sole judge.

Notwithstanding the foregoing, such additional or reduced costs shall not be separately paid or credited if the same has already been accounted for in the price adjustment provisions where applicable, in accordance with the Appendix-2 to the Contract Agreement.

- 29.2 Notwithstanding the foregoing, such additional or reduced costs shall not be separately paid or credited if the same has already been accounted for in the price adjustment provisions where applicable, in accordance with the Appendix-2 to the Contract Agreement.

30. Force Majeure

- 30.1 "Force Majeure" shall mean any event beyond the reasonable control of the Purchaser or of the Supplier, as the case may be, and which is unavoidable notwithstanding the reasonable care of the party affected, and shall include,



without limitation, the following:

- (a) war, hostilities or warlike operations (whether war be declared or not), invasion, act of foreign enemy and civil war,
- (b) rebellion, revolution, insurrection, mutiny, usurpation of government, conspiracy, riot and civil commotion,
- (c) earthquake, landslide, volcanic activity, flood or cyclone, or other inclement weather condition, nuclear and pressure waves or other natural or physical disaster,

30.2 Neither party shall be considered to be in default or in breach of his obligations under the Contract to the extent that performance of such obligation is prevented by any circumstances of Force Majeure, which arises after date of Notification of Award.

30.3 If either party is prevented, hindered or delayed from or in performing any of its obligations under the Contract by an event of Force Majeure, then it shall notify the other in writing of the occurrence of such event and the circumstances thereof within fourteen (14) days after the occurrence of such event.

30.4 The party who has given such notice shall be excused from the performance or punctual performance of its obligations under the Contract for so long as the relevant event of Force Majeure continues and to the extent that such party's performance is prevented, hindered or delayed. The Delivery Schedule shall be extended in accordance with GCC Clause 32.

H. Change in Contract Elements

31. Change in the Facilities

31.1 The Purchaser shall have the right to propose, and subsequently require, that the Project Manager order the Supplier from time to time during the performance of the Contract to make any change, modification, addition or deletion to, in or from the Contract (hereinafter called "Change"), provided that such Change falls within the general scope of the Contract in any one or more of the following:

- (a) drawings, designs, or specifications, where Goods to be furnished under the Contract are to be specifically manufactured for the Purchaser;
- (b) the method of shipment or packing;
- (c) the place of delivery; and
- (d) the Related Services to be provided by the Supplier.

31.2 The pricing of any Change shall, as far as practicable, be calculated in accordance with the rates and prices included in the Contract. If such rates and



prices are inequitable, the parties thereto shall agree on specific rates for the valuation of the Change.

31.2.1 Deleted

31.3 The Purchaser, in addition to situation described in Clause 31.1 above, reserves the right to increase or decrease the quantity of Goods & Related Services specified to the extent of fifteen (15) percent of the Contract Price as originally set forth in Article 2 (Contract Price and Terms of Payment) of the Contract Agreement, without any change in unit price or other terms and conditions during the execution of the Contract. However, the quantities of individual items and services may vary upto any extent.

31.4 If any such change causes an increase or decrease in the cost of, or the time required for, the Supplier's performance of any provisions under the Contract, an equitable adjustment shall be made in the Contract Price or in the Delivery Schedule, and the Contract shall accordingly be amended.

31.5 If the aggregate effect of compliance therewith and with all other Change Orders that have already become binding upon the Supplier under this GCC Clause 31 would be to increase or decrease the Contract Price as originally set forth in Article 2 (Contract Price and Terms of Payment) of the Contract Agreement by more than fifteen (15) percent, the Supplier may give a written notice of objection thereto within twenty-eight (28) days from the date of the Supplier's receipt of the Purchaser's change order. If the Purchaser accepts the Supplier's objection, the Purchaser and the Supplier shall agree on specific rates for valuation of the Change.

31.6 Prices to be charged by the Supplier for any Related Services that might be needed but which were not included in the Contract shall be agreed upon in advance by the parties and shall not exceed the prevailing rates charged to other parties by the Supplier for similar services.

32. Extension of Time

32.1 If at any time during performance of the Contract, the Supplier or its Subcontractors should encounter conditions impeding timely delivery of the Goods or completion of Related Services pursuant to GCC Clause 4, the Supplier shall promptly notify the Purchaser in writing of the delay, its likely duration, and its cause. As soon as practicable after receipt of the Supplier's notice, the Purchaser shall evaluate the situation and may at its discretion extend the Supplier's time for performance, in which case the extension shall be ratified by the parties by amendment of the Contract.



32.2 Except in case of Force Majeure, as provided under GCC Clause 30, a delay by the Supplier in the performance of its Delivery and Completion obligations shall render the Supplier liable to the imposition of liquidated damages pursuant to GCC Clause 21.2, unless an extension of time is agreed upon, pursuant to GCC Sub- Clause 32.1.

33. Termination

33.1 Termination for Default

33.1.1 The Purchaser, without prejudice to any other remedy for breach of Contract, by Notice of default sent to the Supplier, may terminate the Contract in whole or in part:

- (i) if the Supplier fails to deliver any or all of the Goods within the period specified in the Contract, or within any extension thereof granted by the Purchaser pursuant to GCC Clause 32; or
- (ii) if the Supplier fails to perform any other obligation under the Contract.

33.1.2 In the event the Purchaser terminates the Contract in whole or in part, pursuant to GCC Clause 33.1.1, the Purchaser may procure, upon such terms and in such manner as it deems appropriate, Goods or Related Services similar to those undelivered or not performed, and the Supplier shall be liable to the Purchaser for any additional costs for such similar Goods or Related Services. However, the Supplier shall continue performance of the Contract to the extent not terminated.

33.1.3 If the Supplier, in the judgment of the Purchaser has engaged in corrupt or fraudulent practices in competing for or in executing the Contract.

For the purpose of this Sub-Clause:

“Corrupt Practice” means offering, giving, receiving, or soliciting anything of value to influence the action of Purchaser official(s) in the procurement process.

“Fraudulent Practice” means any act including suppression/ misrepresentation of facts, submissions of forged/ false documents, making false declarations etc. that knowingly or recklessly misleads, or attempts to mislead, a party to obtain a financial gain or benefit, or to avoid an obligation, or to influence procurement process to the detriment of interest of the Purchaser, including collusive practices among bidders (prior to or after bid submission) to establish bid prices at artificial, non-competitive levels and to deprive Purchaser of the benefits of competitive prices.

“collusive practice” shall also include an arrangement between two or more parties designed to achieve an illegitimate purpose to the detriment of interest of Purchaser.



“coercive practice” is impairing or harming, or threatening to impair or harm, directly or indirectly, any party or the property of the party to influence improperly the actions of a party;

“Obstructive practice” means

(aa) deliberately destroying, falsifying, altering or concealing of evidence material to the investigation or making false statements to investigators in order to materially impede investigation into allegations of a corrupt, fraudulent, coercive, or collusive practice; and/ or threatening, harassing or intimidating any party to prevent it from disclosing its knowledge of matters relevant to the investigation or from pursuing the investigation,
or

(bb) acts intended to materially impede the exercise of the contractual rights or audit or access to information.

In persuasions of its policy, the Purchaser will sanction a firm or individual, including declaring ineligible, either indefinitely or for a stated period of time, to be awarded a contract if it at any time determines that the firm has, directly or through an agent, engaged in corrupt, fraudulent, collusive, coercive or obstructive practices in competing for, or in executing, a contract.

33.1.4 Any breach by the contractor of the provisions in respect of child labor or any legally mandated provisions relating to labor (particularly on “equal pay for men and women”) shall be a ground for termination of the contract.

33.2 Termination for Insolvency

The Purchaser may at any time terminate the Contract by giving Notice to the Supplier if the Supplier becomes bankrupt or otherwise insolvent. In such event, termination will be without compensation to the Supplier, provided that such termination will not prejudice or affect any right of action or remedy that has accrued or will accrue thereafter to the Purchaser.

33.3 Termination for Convenience

33.3.1 The Purchaser, by Notice sent to the Supplier, may terminate the Contract, in whole or in part, at any time for its convenience. The Notice of termination shall specify that termination is for the Purchaser’s convenience, the extent to which performance of the Supplier under the Contract is terminated, and the date upon which such termination becomes effective.

33.3.2 The Goods that are complete and ready for shipment within twenty- eight (28) days after the Supplier’s receipt of the Notice of termination shall be

accepted by the Purchaser at the Contract terms and prices. For the remaining Goods, the Purchaser may elect:

- (i) to have any portion completed and delivered at the Contract terms and prices; and/or
- (ii) to cancel the remainder and pay to the Supplier an agreed amount for partially completed Goods and Related Services and for materials and parts previously procured by the Supplier.

34. Assignment

34.1 Neither the Purchaser nor the Supplier shall, without the express prior written consent of the other party (which consent shall not be unreasonably withheld), assign to any third party the Contract or any part thereof, or any right, benefit, obligation or interest therein or thereunder.

I. Resolution of Disputes

35. Settlement of Disputes

35.1 Supplier's/Contractor's Claims

Within 42 days after the Contractor became aware (or should have become aware) of the event or circumstance giving rise to the claim or within such other period as may be proposed by the Contractor and approved by the Engineer/Project Manager, the Contractor shall send to the Engineer/Project Manager a fully detailed claim which includes full supporting particulars of the basis of the claim and of the extension of time. If the event or circumstance giving rise to the claim has a continuing effect:

- a) this fully detailed claim shall be considered as interim,
- b) the Contractor shall send further interim claims at monthly intervals, giving the accumulated delay and/or amount claimed and such further particulars as the Engineer/Project Manager may reasonably require; and
- c) the Contractor shall send a final claim within 28 days after the end of the effects resulting from the event or circumstance or within such other period as may be proposed by the Contractor and approved by the Engineer.

Within 90 days after receiving all particulars supporting claim or within such other period as may be proposed by the Engineer/Project Manager and approved by the Contractor, the Engineer shall respond with approval or with disapproval and detailed comments.

Each Payment Certificate shall include such amounts for any claim as have been reasonably substantiated as due under the relevant provision of the Contract.



Unless and until the particulars supplied are sufficient to substantiate the whole of the claim under the Contract, the Contractor shall only be entitled to payment for such part of the claim as he has been able to substantiate.

Further, the resources (Equipment/Manpower) shown in the Data Sheet are solely the Contractor's estimate and the Contractor has committed to deploy the resources indicated to complete the Works within the Time for Completion. No claims will be entertained on the grounds that there has been less progress than anticipated using these resources. The causes or hindrances would have to be established by the Contractor independently. By making these Data Sheets as part of the Contract does not absolve the Contractor from the responsibility of deploying additional resources to complete the Works within Time for Completion. No payments would be made towards the expenses incurred on deploying the additional resources as such unless expressly agreed by the Employer in writing.

No interest shall be paid by the Employer on the disputed/ claimed amount for the period upto determination and notification of the same to the Contractor by the Engineer/announcement of the reasoned award by the IE/CCIE.

35.2 Appointment of the Independent Engineer

Disagreement shall be adjudicated by an Independent Engineer (IE) in accordance with Sub-Clause 35.4 [Obtaining Independent Engineer's Decision].

The Parties i.e. Employer & Contractor shall jointly select one Member from the panel of domain specific Experts being maintained by Ministry of Power (MoP), Government of India to act as Independent Engineer for the Contract. The appointment shall be made within 28 days of signing of Contract Agreement and shall be valid upto Time for Completion specified under SCC [Time for Completion].

It shall be ensured that there is no conflict of interest and IE has not been engaged for providing any other services to any of the Parties in the last three years.

The term of appointment of IE can be further renewed on a year-on-year basis as may be mutually agreed between the Employer and the Contractor subject to the consent of IE and final approval by the MoP.

The agreement between the Parties and the IE shall incorporate by reference the General Conditions of Independent Engineer Agreement contained in the Appendix to these Conditions, with such amendments as are agreed between them.

The terms of the remuneration of IE, shall be as specified in the General Conditions of Independent Engineer Agreement. The cost and expenses of IE shall be equally shared by both Parties.

In the event of non-performance of obligations/services by the IEs at any time during the duration of its contract, the Employer and the Contractor, on mutually agreed basis, shall have the right and discretion to terminate IEs contract by giving a termination notice of thirty (30) days to IE. The appointment of the IE can only be terminated by



mutual agreement of both Parties, but not by the Employer or the Contractor acting alone.

In case the expert is dropped by the Ministry from its panel, a new expert would be selected by the Parties for performing the duties of IE.

The replacement shall be appointed in the same manner as the replaced person was required to have been nominated, as described in this Sub-Clause.

35.3 Failure to Agree Independent Engineer

If any of the following conditions apply, namely:

- (a) the Parties fail to agree upon the appointment of the Independent Engineer by the date stated in the first paragraph of Sub-Clause 35.2, or
- (b) the Parties fail to agree upon the appointment of a replacement person within 42 days after the date on which the IE declines to or is unable to act as a result of death, disability, resignation or termination of appointment, removal from MoP's panel etc.,

then the IE shall be appointed by draw of lots among the experts named in the panel of MoP. This appointment shall be final and conclusive.

35.4 Obtaining Independent Engineer's Decision

If a disagreement (of any kind whatsoever) arises between the Parties in connection with, or arising out of, the Contract or the execution of the Works, including any disagreement as to any certificate, determination, instruction, opinion or valuation of the Employer, then either Party may refer the disagreement in writing to the IE for its decision, with a copy to the other Party. Such reference shall state that it is given under this Sub-Clause and shall be in the Standard Format for Disagreement filing attached as Form-B(below). Necessary documentary evidences shall be submitted with the reference. The reference will not be admissible without initial documentary evidence.

IE shall act as per the Standard Operating Procedure (SOP) attached as Form-A(below).

IE will examine the issue(s) referred by the Parties by conducting inspections involving field measurements as may be required to further investigate and to also conduct hearing/mediation with both the parties.

Based on the preliminary hearing of the Parties, IE shall prescribe resolution timeline depending upon the number and nature of disagreements subject to a maximum duration of thirty (30) days or within extended timeline under extraordinary circumstances and for reasons to be recorded in writing.



Both Parties shall promptly make available to the IE all information, access to the Site, and appropriate facilities, as the IE may require for the purposes of making a decision on such dispute. Necessary information sought by IE during the course of investigation shall be provided in a time bound manner by both the Parties and non-compliance of the same shall lead to imposition of penalties by the IE.

The IE shall be deemed to be not acting as arbitrator.

The IE's decision shall be reasoned and shall state that it is given under this Sub-Clause. However, if the Parties have not paid in full the invoices submitted by IE pursuant to Clause 6 of the Appendix of these Conditions, the IE shall not be obliged to give its decision until such invoices have been paid in full.

The decision shall be binding on both Parties, who shall promptly give effect to it unless and until it shall be revised in an amicable settlement or an arbitral award as described below. Unless the Contract has already been abandoned, repudiated or terminated, the Contractor shall continue to proceed with the Works in accordance with the Contract.

If either Party is dissatisfied with the IE's decision, then either Party may, within 28 days after receiving the decision, give notice to the other Party of its dissatisfaction.

If the IE fails to give its decision within the period of 30 days (or extended timeline) after receiving such reference, then either Party may, within 28 days after this period has expired, give notice to the other Party of its dissatisfaction.

In either event, this notice of dissatisfaction shall state that it is given under this Sub-Clause, and shall set out the matter in dispute and the reason(s) for dissatisfaction. Except as stated in Sub-Clause 36.2 [Failure to Comply with Independent Engineer's Decision] and Sub-Clause 36.3 [Expiry of Independent Engineer's Appointment], neither Party shall be entitled to commence arbitration of a dispute unless a notice of dissatisfaction has been given in accordance with this Sub-Clause.

If the IE has given its decision as to a matter in disagreement to both Parties, and no notice of dissatisfaction has been given by either Party within 28 days after it received the IE's decision, then the decision shall become final and binding upon both Parties.

35.5 Amicable Settlement

If any dispute arises between the Employer and the Contractor in connection with, or arising out of the Contract or the execution of the Works, whether during the execution of the Works or after their completion and whether before or after the repudiation or after termination of Contract, including any disagreement by either party with any action, inaction, opinion, instruction, determination, certificate or valuation of the Employer, an attempt shall be made to resolve the matter in dispute amicably.

Any dispute, in respect of which the Employer and the Contractor have failed to reach at an amicable settlement pursuant to GCC Clause 35.5, shall be finally settled by reference to arbitration as per Clause 36. The Arbitration and Conciliation Act, 1996, as amended up to date, shall govern the arbitration. de to resolve the matter in dispute amicably.

In respect of all matters or actions arising out of the Contract and which may arise at any time, the Courts at Chainpur/Kathmandu, Nepal shall have jurisdiction, subject to Clause 35 thereof (Settlement of Disputes).

36. Arbitration

- 36.1 "Conciliation Committee of Independent Experts (CCIE) for Contractual Disputes in Projects implemented by CPSUs/Statutory Bodies under administrative control of Ministry of Power(Govt. Of India) will address the disputes in terms of MOP's F.No. 11/22/2021-Th.II dated 29.12.2021
- 36.2 Failure to comply with to Com Independent Engineer's Decision

In the event that:

- (a) neither Party has given notice of dissatisfaction within the period stated in Sub-Clause 35.4 [Obtaining Independent Engineer's Decision],
- (b) the IE's related decision (if any) has become final and binding, and
- (c) a Party fails to comply with this decision,

then the other Party may, without prejudice to any other rights it may have, refer the failure itself to arbitration under Sub-Clause 36.1 [Arbitration]. Sub-Clause 35.4 [Obtaining Independent Engineer's Decision] and Sub-Clause 35.5 [Amicable Settlement] shall not apply to this reference.

36.3 Expiry of Independent Engineer's Appointment

If a disagreement arises between the Parties in connection with, or arising out of, the Contract or the execution of the Works and there is no IE in place, by reason of the expiry of the IE's appointment:

- (a) Sub-Clause 35.4 [Obtaining Independent Engineer's Decision] and Sub-Clause 35.5 [Amicable Settlement] shall not apply, and
- (b) the dispute may be referred directly to arbitration under Sub-Clause 36.1 [Arbitration].

Appendix -General Conditions of Independent Engineer Agreement

1 Definitions

"Independent Engineer Agreement" is a tripartite agreement by and between:

- (a) the "Employer";



- (b) the "Contractor"; and
- (c) the "Independent Engineer "

The Employer and the Contractor have entered (or intend to enter) into a contract, which is called the "Contract" and is defined in the Independent Engineer Agreement, which incorporates this Appendix. In the Independent Engineer Agreement, words and expressions which are not otherwise defined shall have the meanings assigned to them in the Contract.

2 General Provisions

The Independent Engineer Agreement shall take effect when the Employer, the Contractor and Independent Engineer have signed a dispute adjudication agreement.

When the Independent Engineer Agreement has taken effect, the Employer and the Contractor shall each give notice to the Independent Engineer accordingly. If the Independent Engineer does not receive either notice within six months after entering into the Independent Engineer Agreement, it shall be void and ineffective.

This employment of the Independent Engineer is a personal appointment. No assignment or subcontracting of the Independent Engineer Agreement is permitted without the prior written agreement of all the Parties to it.

3 Warranties

The Independent Engineer warrants and agrees that he/she is and shall be impartial and independent of the Employer, the Contractor and the Employer's Representative. The Independent Engineer shall promptly disclose, to each of them, any fact or circumstance which might appear inconsistent with his/her warranty and agreement of impartiality and independence.

4 General Obligations of the Independent Engineer

The Independent Engineer shall:

- (a) have no interest financial or otherwise in the Employer or the Contractor, nor any financial interest in the Contract except for payment under the Independent Engineer Agreement;
- (b) not previously have been employed as a consultant or otherwise by the Employer or the Contractor within last three years;
- (c) have disclosed in writing to the Employer and the Contractor, before entering into the Independent Engineer Agreement and to his/her best knowledge and recollection, any professional or personal relationships with any director, officer or employee of the Employer or the Contractor,



and any previous involvement in the overall project of which the Contract forms part;

- (d) not, for the duration of the Independent Engineer Agreement, be employed as a consultant or otherwise by the Employer or the Contractor, except as may be agreed in writing by the Employer and the Contractor;
- (e) comply with the annexed procedural rules and with Sub-Clause 20.4 of the Conditions of Contract;
- (f) not give advice to the Employer, the Contractor, the Employer's Personnel or the Contractor's Personnel concerning the conduct of the Contract, other than in accordance with the annexed procedural rules;
- (g) not while an Independent Engineer enter into discussions or make any agreement with the Employer or the Contractor regarding employment by any of them, whether as a consultant or otherwise, after ceasing to act under the Independent Engineer Agreement;
- (h) ensure his/her availability for any site visit and hearings as are necessary; and
- (i) treat the details of the Contract and all the IE's activities and hearings as private and confidential, and not publish or disclose them without the prior written consent of the Employer and the Contractor.

5 General Obligations of the Employer and the Contractor

The Employer, the Contractor, the Employer's Personnel and the Contractor's Personnel shall not request advice from or consultation with the Independent Engineer regarding the Contract, otherwise than in the normal course of the IE's activities under the Contract and the Independent Engineer Agreement, and except to the extent that prior agreement is given by the Employer and the Contractor. The Employer and the Contractor shall be responsible for compliance with this provision, by the Employer's Personnel and the Contractor's Personnel respectively.

The Employer and the Contractor undertake to each other and to the Independent Engineer shall not, except as otherwise agreed in writing by the Employer and the Contractor:

- (a) be appointed as an arbitrator in any arbitration under the Contract;
- (b) be called as a witness to give evidence concerning any dispute before arbitrator(s) appointed for any arbitration under the Contract; or



- (c) be liable for any claims for anything done or omitted in the discharge or purported discharge of the Independent Engineer 's functions, unless the act or omission is shown to have been in bad faith.

The Employer and the Contractor hereby jointly and severally indemnify and hold the Independent Engineer harmless against and from claims from which he/she is relieved from liability under the preceding paragraph.

6 Payment

The Independent Engineer shall be paid as follows:

- (a) Retainership Fee : A retainer fee of Rs.100,000 per Month fixed for FY 2021-22 for 'Independent Engineer' which shall be considered as payment in full for :
- being available on a notice of 2 weeks for' all site visits and hearings;
 - becoming and remaining conversant with all the project developments and maintaining relevant files; and
 - compensating all office and overhead expenses including secretarial services, photocopying and office supplies incurred in connection with his duties.

The retainer fee of Independent Engineer, shall be increased annually by 10%. Further, an Expert, shall not be in the retainership of more than two contracts concurrently with the same Employer. In case of two contracts, IE shall draw retainership fee limited to one contract only i.e. Rs.100,000 (referred to for FY 21-22). The duration of retainership shall be for such duration as may be mutually decided by the Employer and Contractor but shall not in any case extend beyond 3 months after the completion of works as per the Contract. The retainership fee shall be shared by the Employer and the Contractor equally but shall initially be paid to the IE by the Employer.

- (b) Site Visit Fee : A daily visiting fee of Rs 20,000/- (fixed for FY 21-22) to either project site or project office, anywhere in India, limited to a maximum of 10 days in a month for Expert, shall be paid for hearing, preparing reports etc. The daily fee shall be shared by the Employer and the Contractor equally but shall initially be paid to the IE by the Employer. The daily visiting fee of Expert, as mentioned above, shall be increased on yearly basis @10%.
- (c) Reimbursement of travel, boarding/lodging expenses incurred by 'Independent Engineer': The travel, boarding/lodging expenses of the 'Independent Engineer, as per entitlement of Executive Director of Employer, would be paid initially by the Contractor. If any expert of 'Independent Engineer' does not receive payment of the amount due within 30 days after submitting claim, the expert shall be free to suspend his/her services without notice until the payment is received.



- (d) Meeting Expenses: All the payments for holding the meeting would be initially paid by the Contractor and shall be shared equally by the Employer and Contractor.
- (e) Sharing of Expenses on Independent Engineer : All the payments for holding the meeting, site visits, reimbursement of travel, boarding/lodging expenses and monthly compensation of 'Independent Engineer' shall be shared equally by both the parties i.e. Employer and Contractor.

7 Default of the Independent Engineer

If the IE fails to comply with any obligation under Clause 4, he/she shall not be entitled to any fees or expenses hereunder and shall, without prejudice to their other rights, reimburse each of the Employer and the Contractor for any fees and expenses received by the IE, for proceedings or decisions (if any) of the IE which are rendered void or ineffective.

8 Dispute

Any dispute or claim arising out of or in connection with this Agreement, or the breach, termination or invalidity thereof, shall be finally settled under the Rules of Arbitration of the Arbitration Institute referred in Sub-Clause 20.6 [Arbitration] by one arbitrator appointed in accordance with these Rules.

Annex - Procedural Rules

- 1 The Employer and the Contractor shall furnish to the IE one copy of all documents which the IE may request, including Contract documents, progress reports, variation instructions, certificates and other documents pertinent to the matter in disagreement. All communications between the IE and the Employer or the Contractor shall be copied to the other Party.
- 2 The IE shall proceed in accordance with Sub-Clause 35.4 and these Rules. Subject to the time allowed to give notice of a decision and other relevant factors, the IE shall:
 - (a) act fairly and impartially as between the Employer and the Contractor, giving each of them a reasonable opportunity of putting his case and responding to the other's case, and
 - (b) adopt procedures suitable to the disagreement, avoiding unnecessary delay or expense.
- 3 The IE may conduct a hearing on the disagreement, in which event it will decide on the date and place for the hearing and may request that written documentation and arguments from the Employer and the Contractor be presented to it prior to or at the hearing.
- 4 Except as otherwise agreed in writing by the Employer and the Contractor, the IE shall have power to adopt an inquisitorial procedure, to refuse admission to



hearings or audience at hearings to any persons other than representatives of the Employer and the Contractor, and to proceed in the absence of any party who the IE is satisfied received notice of the hearing; but shall have discretion to decide whether and to what extent this power may be exercised.

- 5 The Employer and the Contractor empower the IE, among other things, to:
- (a) establish the procedure to be applied in deciding a disagreement,
 - (b) decide upon the IE's own jurisdiction, and as to the scope of any disagreement referred to it,
 - (c) conduct any hearing as it thinks fit, not being bound by any rules or procedures other than those contained in the Contract and these Rules,
 - (d) take the initiative in ascertaining the facts and matters required for a decision,
 - (e) make use of its own specialist knowledge, if any,
 - (f) decide upon the payment of financing charges in accordance with the Contract,
 - (g) decide upon any provisional relief such as interim or conservatory measures, and
 - (h) open up, review and revise any certificate, decision, determination, instruction, opinion or valuation of the Employer, relevant to the disagreement.
- 6 The IE shall not express any opinions during any hearing concerning the merits of any arguments advanced by the Parties. Thereafter, the IE shall make and give its decision in accordance with Sub-Clause 35.4, or as otherwise agreed by the Employer and the Contractor in writing.

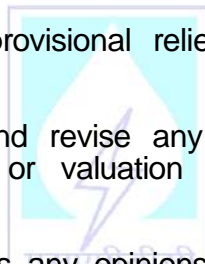

Form-A

(Refer sub-clause 35.4 of GCC)

Standard Operating Procedure (SOP) for Independent Engineer

The Independent Engineer shall act as per Standard Operating Procedure (SOP) (issued by the Ministry of Power(Govt. of India) vide Office Memorandum no. 15-18/1/2020-HYDEL-II(MoP) dated 27.09.2021 or as amended from time to time)

| S. No. | Key Tasks | Stakeholder involvement | Activity description | Proposed Timeline |
|---------------|----------------------------------|--|---|--------------------------|
| 1 | Reference of Disagreement | <ul style="list-style-type: none"> – Contractor – Employer | Case Filing — A Disagreement begins when claimant party submits a demand for intervention by IE in the prescribed format along with documentary evidence. Demand without initial documentary evidence will not be admissible for IE intervention. | Day 0 |
| 2 | Preliminary Hearing & Scheduling | <ul style="list-style-type: none"> – Independent Engineer – Contractor – Employer | Preliminary hearing and scheduling process- IE to organize a preliminary hearing with the parties and prescribe suitable timeline for resolution or settlement. | Day 1 to Day 6 |
| 3 | Finalisation of Issues | <ul style="list-style-type: none"> – Independent Engineer | Finalisation of Issues — After due examination and diligence to finalise the issues requiring resolution. | Day 3 to 9 |
| 4 | Hearing/ Mediation | <ul style="list-style-type: none"> – Independent Engineer – Contractor – Employer | Hearing / Mediation—The parties and IE meet in person to conduct the Hearings. | Day 4 to 12 |
| 5 | Inspection | <ul style="list-style-type: none"> – Independent Engineer | Inspection- IE conducts the inspections involving field measurements, if any, to further investigate evidence conferred to the IE by both parties during the hearing. | Day 5 to 17 |



| S. No. | Key Tasks | Stakeholder involvement | Activity description | Proposed Timeline |
|--------|------------------------|--|--|-------------------|
| 6 | Post Inspection Briefs | <ul style="list-style-type: none"> – Independent Engineer – Contractor – Employer | Post-Inspection Briefs - After the inspection takes place; both the parties may come up with additional testimony, as permitted by the IE. | Day 10 to 30 |
| 7 | Closure | <ul style="list-style-type: none"> – Independent Engineer | Closure - IE closes the report on the case and issues a decision, along with any claim settlement, if applicable. | Day 10 to 30 |





Form-B

Standard Format for Disagreement Filing

| | | |
|--|---|--|
| 1. Name of Party | 2. Disagreement Reporting Date | 3 Has the documentary Evidence been Submitted |
| | | |
| 4 Contract Reference number | 5. Party Representative Name Reporting Disagreement | <input type="checkbox"/> Yes |
| | Name: Contact | <input type="checkbox"/> No |
| | Details: | <input type="checkbox"/> Not Applicable |
| 6. Name of Independent Engineer IE | 7. IE Contact details | 8. Disagreement Reference Number (to be allocated by IE) |
| | | |
| 9. Supplementary Note Recording the Disagreement | | |
| [Text] | | |
| Documentary Evidences to be Annexed | | |
| 10. Critical Engineering Expertise Relevant to Investigate the Disagreement (Check All Required) | | |
| <input type="checkbox"/> Engineering Design <input type="checkbox"/> Geology <input type="checkbox"/> Civil works <input type="checkbox"/> Hydro Mechanical <input type="checkbox"/> Electro Mechanical <input type="checkbox"/> Electrical Switchgear <input type="checkbox"/> Quality Assurance & Inspection | | |



| |
|--|
| 11. Record Notes of Preliminary hearing Organized by IE with the parties |
| [Text] Documentary Evidences by Parties along with MoM to be Annexed |
| 12. Brief Narration on discovery process - after Preliminary hearing & listing of next step to examine the issues and procedural difficulties relating to the case |
| [Text] Documentary Evidences to be Annexed |
| 13. Record notes of Hearing/Mediation between the parties and IE |
| [Text] Documentary Evidences with Video Records to be Annexed |
| 14. Inspection Records with Field Measurements Conducted by IE |
| [Text] Documentary Evidences to be Annexed |
| 15. Record notes of Inspection Briefs by IE along with additional testimony by the Parties if any |
| [Text] Documentary Evidences & inspection Reports to be Annexed |
| 16. Closure Report by IE with Decision & Claim settlement if applicable |
| [Text] Documentary Evidences to be Annexed |
| Final Acceptance by All the Parties |

----- End of Section-IV (GCC) -----

VOLUME-I

SECTION – V

SPECIAL CONDITIONS OF CONTRACT (SCC)

SPECIAL CONDITIONS OF CONTRACT (SCC)

The following bid specific data for the Goods and Related Services to be procured shall amend and/or supplement the provisions in the General Conditions of Contract (GCC).

| Sl. No. | GCC Clause Ref. No. | Amendment/Supplement to GCC | | | | | | | | | | | | | | | | | | |
|-------------------------------|---|--|--|---|-------------------------------|---------|-----|----|--------|--|-----|-----|---------|-----|-----|---------|-------------------------------|--|---------|--|
| 1. | GCC 1.1 (k) | <p>Supplementing Sub-Clause GCC 1.1(k) The delivery schedule (i.e., Receipt at Site) for the Goods and Related Services to be supplied under the subject packages shall be as follows:</p> <table border="1" style="width: 100%; border-collapse: collapse;"> <thead> <tr> <th style="text-align: center;">Mile Stones</th> <th style="text-align: center;">Duration in days from the date of Notification of Award</th> <th style="text-align: center;">Quantity to be supplied in KM</th> <th style="text-align: center;">Remarks</th> </tr> </thead> <tbody> <tr> <td style="text-align: center;">1st</td> <td style="text-align: center;">90</td> <td style="text-align: center;">500 KM</td> <td rowspan="3" style="vertical-align: top;">The Bidder is required to supply the Quantity mentioned as per time Schedule. The quantities mentioned are minimum i.r.o each milestone, however, bidder may supply additional quantities i.e upto 2799 KM .</td> </tr> <tr> <td style="text-align: center;">2nd</td> <td style="text-align: center;">120</td> <td style="text-align: center;">1000 KM</td> </tr> <tr> <td style="text-align: center;">3rd</td> <td style="text-align: center;">180</td> <td style="text-align: center;">1299 KM</td> </tr> <tr> <td colspan="2" style="text-align: center;">Total Quantity to be supplied</td> <td style="text-align: center;">2799 KM</td> <td></td> </tr> </tbody> </table> | Mile Stones | Duration in days from the date of Notification of Award | Quantity to be supplied in KM | Remarks | 1st | 90 | 500 KM | The Bidder is required to supply the Quantity mentioned as per time Schedule. The quantities mentioned are minimum i.r.o each milestone, however, bidder may supply additional quantities i.e upto 2799 KM . | 2nd | 120 | 1000 KM | 3rd | 180 | 1299 KM | Total Quantity to be supplied | | 2799 KM | |
| Mile Stones | Duration in days from the date of Notification of Award | Quantity to be supplied in KM | Remarks | | | | | | | | | | | | | | | | | |
| 1st | 90 | 500 KM | The Bidder is required to supply the Quantity mentioned as per time Schedule. The quantities mentioned are minimum i.r.o each milestone, however, bidder may supply additional quantities i.e upto 2799 KM . | | | | | | | | | | | | | | | | | |
| 2nd | 120 | 1000 KM | | | | | | | | | | | | | | | | | | |
| 3rd | 180 | 1299 KM | | | | | | | | | | | | | | | | | | |
| Total Quantity to be supplied | | 2799 KM | | | | | | | | | | | | | | | | | | |
| 2. | GCC 1.1(t) | <p>Supplementing Sub-Clause GCC 1.1(t) The Owner is:</p> <p>SAPDC, Arun-3 HEP, Satluj Bhawan, Arun Sadan, Tumlingtar, Distt. Sankhuwasabha, Nepal</p> <p style="text-align: center;">Or</p> <p>SAPDC, Arun-3 HEP, 3rd Floor, Citizen Investment Trust(CIT) Building, Near to Investment Board of Nepal (IBN), New Bhaneshwor, Kathmandu</p> <p>Ph: +977 029-575154, +977 029-575141 Kind Attn.: Mr. Arun Dhiman, CEO, SAPDC</p> | | | | | | | | | | | | | | | | | | |



| Sl. No. | GCC Clause Ref. No. | Amendment/Supplement to GCC |
|---------|---------------------|---|
| 3. | GCC 1.1(w) | <p>Supplementing Sub-Clause GCC 1.1(w)</p> <p>The Purchaser is: SAPDC, Arun-3 HEP, Satluj Bhawan, Arun Sadan, Tumlingtar, Distt. Sankhuwasabha, Nepal</p> <p style="text-align: center;">Or</p> <p>SAPDC, Arun-3 HEP, 3rd Floor, Citizen Investment Trust(CIT) Building, Near to Investment Board of Nepal (IBN), New Bhaneshwor, Kathmandu</p> <p>Ph: +977 029-575154, +977 029-575141 Kind Attn.: Mr. Arun Dhiman, CEO, SAPDC</p> |
| 4. | GCC 1.1 (ee) | <p>Add new sub clause GCC 1.1 (ee):</p> <p>For execution of the subject Conductor Packages CD03 Owner/Purchaser shall discharge their duties in accordance with agreement signed between them.</p> |
| 5. | GCC 9.3.5 | <p>Add new sub Clause GCC 9.3.5</p> <p>No interest shall be payable by the Purchaser on the performance Security.</p> |
| 6. | GCC 17 | <p>Supplementing GCC 17 with the following:</p> <p>All the acts/laws/rules mentioned hereunder shall be dealt as per corresponding Nepal Government's applicable acts/laws/rules.</p> |
| 7. | GCC 20.3 | <p>The expected schedule of commissioning of the Facilities wherein the Goods under the Contract are to be installed is 28 (Twenty Eight) months from the effective date of Contract.</p> |

----- End of Section-V (SCC) -----

VOLUME-I

SECTION – VI

SAMPLE FORMS AND PROCEDURES (FORMS)(FP)

Table of Content

- 1. BID FORMS AND PRICE SCHEDULES**
- 2. BID SECURITY FORM**
 - (A) BID SECURITY FORM (FOR PACKAGE CD-03)
- 3. FORM OF NOTIFICATION BY THE PURCHASER TO THE BANK**
- 4. FORM OF 'NOTIFICATION OF AWARD OF CONTRACT**
- 5. FORM OF CONTRACT AGREEMENT**
- APPENDIX-1 (TERMS AND PROCEDURES OF PAYMENT)**
- APPENDIX- 2 (PRICE ADJUSTMENT)**
- APPENDIX- 3 (INSURANCE REQUIREMENTS)**
 - APPENDIX- 4 (TIME SCHEDULE)
 - APPENDIX- 5 (LIST OF APPROVED SUBCONTRACTORS)
 - APPENDIX- 6 (LIST OF DOCUMENTS FOR APPROVAL OR REVIEW)
 - APPENDIX- 7
- 6. PERFORMANCE SECURITY FORM**
- 7. BANK GUARANTEE FORM FOR ADVANCE PAYMENT**
- 8. FORM OF TAKING OVER CERTIFICATE**
- 9. FORM OF EXTENSION OF BANK GUARANTEE**
- 10.FORM OF POWER OF ATTORNEY FOR JOINT VENTURE**
- 11.FORM OF UNDERTAKING BY THE JOINT VENTURE PARTNERS**
- 12.FORMAT FOR EVIDENCE OF ACCESS TO OR AVAILABILITY OF CREDIT/FACILITIES**
- 13.FORM OF MATERIAL ACCEPTANCE CERTIFICATE**
- 14.FORM OF JOINT DEED OF UNDERTAKING BY THE LICENSOR ALONGWITH THE BIDDER**
- 15.FORM OF BANK GUARANTEE FOR CONTRACT PERFORMANCE (TO BE SUBMITTED BY LICENSOR)**
- 16.PERFORMANCE SECURITY FORM**



SAMPLE FORMS AND PROCEDURES (FORMS)

Preamble

This Section (Section –VI) of the bidding documents [named as Sample Forms and Procedures (FORMS)] provides proforma to be used by the bidders at the time of their bid preparation and by the Supplier subsequent to the award of Contract.

The Bidder shall complete, sign and submit with its bid the relevant FORMS to be used unamended, in accordance with the requirements included in the Bidding Documents.

The Bidder shall provide the Bid Security, either in the form included hereafter or in another form acceptable to the Purchaser, pursuant to the provisions in the instructions to Bidders.

The Form of Contract Agreement shall be used unamended, except for the need to complete Article 1.1 (Contract Documents), as appropriate and as may be required to suit the specific requirement of the Contract. The form shall also include the Appendices listed, as required, which should be completed according to the instructions for their completion provided at the beginning of each Appendix. The Price Schedule deemed to form part of the contract shall be modified according to any corrections or modifications to the accepted bid resulting from price corrections, pursuant to the provisions of the Instructions to Bidders.

The Performance Security(ies) and Bank Guarantee for Advance Payment forms should not be completed by the bidders at the time of their bid preparation. Only the successful Bidder will be required to provide the Performance Security(ies) and Bank Guarantee for Advance Payment, according to one of the forms indicated herein or in another form acceptable to the Purchaser and pursuant to the provisions of the General and Special Conditions of Contract, respectively.

Depending on specific facts and circumstances related to the Bid, other specific agreement, if any, and the contract, the text of the Forms herein may need to be modified to some extent. The Purchaser reserves the right to make such modifications in conformity with such specific facts and circumstances and rectify and consequent discrepancies, if any. However, modifications, if any, to the text of the Forms that may be required in the opinion of the Bidder/Supplier shall be effected only if the same is approved by the Purchaser. The Purchaser's decision in this regard shall be final and binding.



1. ID FORMS AND PRICE SCHEDULES

1.1 Technical Bid Form for Envelope-I

Please see Volume – III.

1.2 Bid Form & Price Schedule for Envelope-II

Please see Volume – III





2. BID SECURITY FORM

Bid Security Form (for Conductor Package CD03)

((To be stamped in accordance with Stamp Act, the Non-Judicial Stamp Paper should be in the name of the issuing Bank. For the purpose of verification/confirmation of this Bank Guarantee by the Purchaser, the Bank shall indicate 2 official email ids of the authorized signatories from Issuing Branch and also of the designated higher office (Corporate Office, Zonal Office etc)in the covering letter of the Bank forwarding the Bank Guarantee.))

Bank Guarantee No.:

Date:

To

SAPDC, Arun-3 HEP,
Satluj Bhawan, Arun Sadan, Tumlingtar,
Distt. Sankhuwasabha, Nepal

WHEREAS M/s. *(Insert name of Bidder)*..... having its Registered/Head Office at *(Insert address of the Bidder)* (Hereinafter called "the Bidder" **which expression shall include its successors, administrators, executors and assigns**) has submitted its Bid for the performance of the Contract for **Conductor Package CD03 for supply of ACSR MOOSE Conductor for part of Diding – Dhalkebar – Bathnaha Transmission Line corresponding to Tower Package-TW02 associated with Arun-3 HEP in Nepal under Specification No.: SAPDC/P&C/Arun-3HEP/CD03/2023** (Hereinafter called "the Bid")

KNOW ALL PERSONS by these present that WE *(insert name & address of the issuing bank)* having its Registered/Head Office at*(insert address of registered office of the bank)*..... (hereinafter called "the Bank" **which expression shall include its successors, administrators, executors and assigns**), are bound unto **M/s. SJVN Arun-3 Power Development Company Pvt. Ltd. (SAPDC)** (hereinafter called "the Purchaser" in the sum of*(insert amount of Bid Security in figures & words)*.....
..... for which payment well and truly to be made to the said Purchaser, the Bank binds itself, its successors and assigns by these presents.

Sealed with the Common Seal of the said Bank this day of
23....



THE CONDITIONS of this obligation are:

- (1) If the Bidder withdraws its bid during the period of bid validity specified by the Bidder in the Bid Form; or
- (2) In case the Bidder does not withdraw the deviations proposed by him, if any, at the cost of withdrawal stated by him in the bid and/or accept the withdrawals/rectifications pursuant to the declaration/confirmation made by him in Attachment – Declaration of the Bid; or
- (3) If the Bidder does not accept the corrections to arithmetical errors identified during preliminary evaluation of his bid pursuant to ITB Clause 27.2; or
- (4) If, as per the requirement of Qualification Requirements the Bidder is required to submit a Deed of Joint Undertaking and he fails to submit the same, duly attested by Notary Public of the place(s) of the respective executants (s) or registered with the Indian Embassy/High Commission in that Country, within ten days from the date of intimation of post – bid discussion; or
- (5) In the case of a successful Bidder, if the Bidder fails within the specified time limit
 - (i) To sign the Contract Agreement, in accordance with ITB Clause 34, or
 - (ii) To furnish the required performance security, in accordance with ITB Clause 35.or
- (6) In any other case specifically provided for in ITB.

WE undertake to pay to the Purchaser up to the above amount upon receipt of its first written demand, without the Purchaser having to substantiate its demand, provided that in its demand the Purchaser will note that the amount claimed by it is due to it, owing to the occurrence of any of the above-named CONDITIONS or their combination, and specifying the occurred condition or conditions.

This guarantee will remain in full force up to and including (**insert date in line with ITB Clause 13**)....., and any demand in respect thereof must reach the Bank not later than the above date.

Notwithstanding anything contained herein:



1. Our liability under this Bank Guarantee shall not exceed _____ (value in figures)_____ [_____ (value in words)_____].
2. This Bank Guarantee shall be valid upto _____ (validity date)_____.
3. We are liable to pay the guaranteed amount or any part thereof under this Bank Guarantee only & only if we receive a written claim or demand on or before _____ (validity date) _____

For and on behalf of the Bank

[Signature of the authorised signatory(ies)]

Signature_____

Name_____

Designation_____

POA Number_____

Contact Number(s): Tel._____ Mobile_____

Fax Number_____

email_____

Common Seal of the Bank_____

Witness:

Signature_____

Name_____

Address_____

Contact Number(s): Tel._____ Mobile_____

email_____

Note:



1. In case the bid is submitted by a Joint Venture, the bid security shall be in the name of the Joint Venture and not in the name of the Lead Partner or any other Partner(s) of the Joint Venture. **[Not Applicable]**
2. The Bank Guarantee should be in accordance with the proforma as provided. However, in case the issuing bank insists for additional paragraph regarding applicability of ICC publication No: 758, the following may be added at the end of the proforma of the Bank Guarantee [*i.e., end paragraph of the Bank Guarantee preceding the signature(s) of the issuing authority(ies) of the Bank Guarantee*]:

“This Guarantee is subject to Uniform Rules for Demand Guarantee, ICC publication No. 758.”





3. FORM OF NOTIFICATION BY THE PURCHASER TO THE BANK

3a. FORM OF NOTIFICATION BY THE PURCHASER TO THE BANK

(Applicable for Forfeiture of Bank Guarantee)

To: *(insert Name and Address of the issuing Bank)*

Ref.: Forfeiture of Bid Security Amount against Bank Guarantee No.
..... dated for, issued by you on behalf of M/s.
.....*(insert name of the Bidder)*

Dear Sirs,

Please refer to the subject Bank Guarantee executed by you in our favour for
..... as Bid Security for the bid submitted by M/s.*(insert name
of the Bidder)* against *(insert name of the Package)* ;
Specification No.

As per the terms of the said guarantee, the bank has guaranteed and undertaken to
pay immediately on demand by the Purchaser the amount of without
any reservation, protest, demur and recourse. Further, any demand made by the
Purchaser shall be conclusive and binding on the Bank irrespective of any dispute
or difference raised by the Bidder.

In terms of the said guarantee, we hereby submit our claim/demand through this
letter for remittance of Bid Security amount to *(insert name of the Purchaser)*
..... owing to the occurrence of the condition referred to at Sl. No. The
Bank is requested to remit the full guaranteed sum towards
proceeds of the bid security in the form of Demand Draft in favour of '*.... (insert
name of the Purchaser)*', payable at*(insert place of the Purchaser)*....

Thanking you,

For.....(Name of the Purchaser)

(AUTHORISED SIGNATORY)

Copy to:

.....*(Registered Office of the Bank)*....



3b. FORM OF NOTIFICATION BY THE PURCHASER TO THE BANK
(Applicable for conditional claim pending extension of Bank Guarantee by the Bidder)

To: *(insert Name and Address of the issuing Bank)*

Ref.: Conditional Claim against Bank Guarantee No. dated
..... for valid up to issued by you on behalf of M/s.
.....*(insert name of the Bidder)*

Dear Sirs,

Please refer to the subject Bank Guarantee executed by you in our favour on behalf of M/s.*(insert name of the Bidder)*, who have submitted this Bank Guarantee to us towards Bid Security against *(insert name of the Package)* ; Specification No.

We, *(insert name of the Purchaser)* do hereby request you to lodge our claim/demand against the subject Bank Guarantee for full guaranteed sum. Kindly note that this claim/demand against the subject Bank Guarantee is without any further notice in case the amendment to Bank Guarantee No. dated extending its validity upto is not got arranged by*(insert name of the Bidder)* in our favour and are not received by us upto In such an event you are requested to remit the full guaranteed amount in terms of the subject guarantee in its letter and spirit and proceeds of this Bank Guarantee shall be forwarded to us in form of demand draft in favour of '.... *(insert name of the Purchaser)*, payable at*(insert place of the Purchaser)*....'.

This is without prejudice to our right under this guarantee and under the law.

Thanking you,

For.....*(Name of the Purchaser)*

(AUTHORISED SIGNATORY)

Copy to:
(insert Name and Address of the Bidder)

- You are requested to do the needful so that the amendment to the subject Bank Guarantee extending the validity up to is received by us by.....



4. FORM OF 'NOTIFICATION OF AWARD OF CONTRACT'

[Alternative – 1 : Applicable wherein the Supplier is an Nepalese Firm]

4a. FORM OF 'NOTIFICATION OF AWARD OF CONTRACT 'FOR SUPPLY OF GOODS'

Ref. No. :

Date :

.....(*insert Supplier's Name & Address*).....

.....

.....

.....

[in case of Joint Venture, the aforesaid details shall be of the Lead Partner and the following shall also be included:

(Lead Partner of the Joint Venture of M/s. and M/s.)]

Attn : Mr.....

Sub. :Notification of Award for **Supply of Goods Contract for** (*insert name of the Package*) Specification No.: Domestic/Global Competitive Bidding. (Project Funding: Domestic).

Dear Sir,

1.0 REFERENCE

This has reference to the following:

1.1 Our Invitation for Bids (IFB) dated

1.2 Bidding documents for the subject package issued to you vide our letter Ref. No. dated, comprising the following:

a) Conditions of Contract Volume-I
(Document Code No.)

b) Technical Specifications Volume-II
(Document Code No.)



c) Bid Form, Price Schedules Volume-III & Technical Data Sheets
(Document Code No.)

1.2.1 Amendment/Errata No. to Bidding Documents issued to you vide our letter no. dated
(Applicable only if any Errata/Amendment to the Bidding Documents has been issued subsequently)

1.2.2 Clarifications to the Bidding Documents, pursuant to pre-bid conference held on, issued to you vide our letters no. dated
(Use as applicable)
(Applicable only if any clarification to the Bidding Documents has been issued subsequently)

(INCLUDE AS FURTHER SUB-PARAGRAPHS ANY OTHER CORRESPONDENCE MADE TO THE BIDDER AFTER ISSUANCE OF BIDDING DOCUMENTS UP TO BID OPENING)

1.3 First envelope of your Bid submitted/the Bid submitted by the Joint Venture (JV) of M/s. (Lead Partner) and M/s. (Other Partner) for the subject package under Proposal reference no. dated was opened on
(Use as applicable)

1.4 Intimation for Opening of Second Envelope issued to you vide our letter no. dated

1.5 Second Envelope of your Bid/the Bid by the Joint Venture (JV) of M/s. (Lead Partner) and M/s. (Other Partner) under proposal reference no. dated was opened on.....
(Use as applicable)

1.6 Post bid discussions we had with you on various dates from to resulting into the Minutes of Meeting/ Record Notes of Post Bid Discussions enclosed as APPENDIX (NOA)-1 with this Notification of Award.

2.0 AWARD OF CONTRACT AND ITS SCOPE

2.1 We confirm having accepted your Bid/Bid of the Joint Venture (JV) of M/s. (Lead Partner) and M/s. (Other Partner) *(Use*



as applicable) (referred to at para 1.3 & 1.5 above) read in conjunction with all the specifications, terms & conditions of the Bidding Documents (referred to at para 1.2, 1.2.1 & 1.2.2 [modify as applicable] above) and specific confirmations recorded in the Record Notes of Post Bid Discussions (referred to at para 1.6 above), and award on you/the JV (use as applicable) the **'Supply of Goods Contract'** (also referred to as the **'First Contract'**) covering inter-alia Ex-works supply of all equipment and materials including Type Testing to be conducted, required for the complete execution of the (insert name of Package alongwith name of the Project), as detailed in the documents referred hereinabove. The scope of work inter-alia includes the following:

..... (Indicate brief Scope of Work)

The scope of work under this Notification of Award (NOA) shall also include all such items which are not specifically mentioned in the Bidding Documents and/or your bid but are necessary for successful, efficient, safe and reliable operation of the goods, as detailed in the Bidding Documents unless otherwise specifically excluded in the Bidding Documents or in this Notification of Award.

2.1.1 You, the Lead Partner of the JV, along with M/s., the Other Partner of JV, shall be liable jointly and severally for the execution of the Contract in accordance with terms and conditions of the Contract. As per the Power of Attorney furnished in your favour by the Joint Venture, as enclosed with Bid Proposal of the JV, you shall act as the Partner In-charge (Lead Partner) of the above Joint Venture for execution of the Contract. (This provision shall be included only in case the Bidder is a Joint Venture).

2.2 The notification for award of Contract for performance of all other activities, as set forth in the Bidding Documents, viz.

..... (Indicate brief scope of work of the Second Contract)has been issued on you vide our NOA no. dated (hereinafter called the "Second Contract" or "**Supply of Services Contract**").

Notwithstanding the award of work under two separate Contracts in the aforesaid manner, you/the JV (use as applicable) shall be overall responsible to ensure the execution of both the Contracts to achieve successful completion and taking over of the Goods under the package by the Purchaser



as per the requirements stipulated in the Bidding Documents. It is expressly understood and agreed by you/the JV (*use as applicable*) that any default or breach under the 'Second Contract' shall automatically be deemed as a default or breach of this 'First Contract' also and vice-versa, and any such default or breach or occurrence giving us a right to terminate the 'Second Contract', either in full or in part, and/or recover damages there under, shall give us an absolute right to terminate this Contract, at your/JV's (*use as applicable*) risk, cost and responsibility, either in full or in part and/or recover damages under this 'First Contract' as well. However, such default or breach or occurrence in the 'Second Contract', shall not automatically relieve you/the JV (*use as applicable*) of any of your/JV's (*use as applicable*) obligations under this 'First Contract'. It is also expressly understood and agreed by you/the JV (*use as applicable*) that the equipment/materials supplied by you/the JV (*use as applicable*) under this 'First Contract', when **inter-alia transported to site (to be suitably modified in case of Supply-cum-supervision packages)** by you under the 'Second Contract' shall give satisfactory performance in accordance with the provisions of the Contract.

3.0 **CONTRACT PRICE**

3.1 The total Contract Price for the entire scope of work under this Contract shall be (*Specify the currency and the amount in figures & words*) as per the following break-up:

| Sl.No. | Price Component | Amount |
|---|--------------------------|--------|
| 1. | Ex-Works Price component | |
| 2. | Type Test Charges | |
| Total for Supply of Goods Contract | | |

3.2 Notwithstanding the break-up of the Contract Price, the Contract shall, at all times, be construed as a single source responsibility Contract and any breach in any part of the Contract shall be treated as a breach of the entire Contract.

4.0 You/The JV (*use as applicable*) are/is required to furnish at the earliest a Performance Security(ies), as per the Bidding Documents, for an amount of (*Specify the value*) i.e. equal to 3% (Three percent) of the Contract Price, and valid upto and including and any other securities as per the Bidding Documents.

(In case any other performance security is required to be furnished, the same is to be mentioned here)

- 5.0 For release of advance payment (admissible as per the Bidding Documents) equal to% of the Ex-works Price component of the Contract Price, you are, inter-alia, required to furnish a Bank Guarantee for **[110% (one hundred ten percent) of the amount of Advance]**. The validity of the Advance Bank Guarantee shall be up to and including Further, please note that furnishing of the Contract Performance Security(ies) under the 'First Contract' and 'Second Contract' shall be one of the conditions precedent to release of advance under this Contract.
- 6.0 All the bank guarantees shall be furnished from an eligible bank as described in the Bidding Documents.
- 7.0 The delivery schedule for the supply of goods under the contract shall be construed from the date of issue of this Notification of Award for all contractual purposes as per below:

| Commencement of Delivery (Ex-works) | Completion of delivery (Site) | Approx. rate of supply <i>(This column shall be applicable for Insulator & Conductor Packages only)</i> |
|--|--|--|
| months from the date of Notification of Award | months from the date of Notification of Award | Total quantity equally distributed over the total delivery period. |

- 8.0 This Notification of Award constitutes formation of the Contract and comes into force with effect from the date of issuance of this Notification of Award.
- 9.0 You shall enter into a Contract Agreement with us within twenty-eight (28) days from the date of this Notification of Award.
- 10.0 This Notification of Award is being issued to you in duplicate. We request you to return its duplicate copy duly signed and stamped on each page including the enclosed Appendix as a token of your acknowledgement.

Please take the necessary action to commence the work and confirm action.
Yours faithfully,

For and on behalf of
.....(Name of the Purchaser).....
(Authorised Signatory)

Enclosures:

APPENDIX (NOA)-1 - Record Notes of Post - Bid Discussions held on various dates from to



4b. FORM OF 'NOTIFICATION OF AWARD OF CONTRACT' FOR SUPPLY OF SERVICES'

Ref. No. :

Date :

.....(insert Supplier's Name & Address).....

.....

.....

.....

[in case of Joint Venture, the aforesaid details shall be of the Lead Partner and the following shall also be included:

(Lead Partner of the Joint Venture of M/s. and M/s.)]

Attn : Mr.....

Sub. : Notification of Award for **Supply of Services** Contract (insert name of the Package) Specification No.: Domestic/Global Competitive Bidding. (Project Funding: Domestic).

Dear Sir,

1.0 REFERENCE

This has reference to the following:

1.1 Our Invitation for Bids (IFB) dated

1.2 Bidding documents for the subject package issued to you vide our letter Ref. No. dated, comprising the following:

a) Conditions of Contract Volume-I
(Document Code No.)

b) Technical Specifications Volume-II
(Document Code No.)

c) Bid Form, Price Schedules Volume-III & Technical Data Sheets
(Document Code No.)





1.2.1 Amendment/Errata No. to Bidding Documents issued to you vide our letter no. dated
(Applicable only if any Errata/Amendment to the Bidding Documents has been issued subsequently)

1.2.2 Clarifications to the Bidding Documents, pursuant to pre-bid conference held on, issued to you vide our letters no. dated
(Use as applicable)
(Applicable only if any clarification to the Bidding Documents has been issued subsequently)

(INCLUDE AS FURTHER SUB-PARAGRAPHS ANY OTHER CORRESPONDENCE MADE TO THE BIDDER AFTER ISSUANCE OF BIDDING DOCUMENTS UP TO BID OPENING)

1.3 First envelope of your Bid submitted/the Bid submitted by the Joint Venture (JV) of M/s. (Lead Partner) and M/s. (Other Partner) for the subject package under Proposal reference no. dated was opened on
(Use as applicable)

1.4 Intimation for Opening of Second Envelope issued to you vide our letter no. dated

1.5 Second Envelope of your Bid/the Bid by the Joint Venture (JV) of M/s. (Lead Partner) and M/s. (Other Partner) under proposal reference no. dated was opened on.....
(Use as applicable)

1.6 Post bid discussions we had with you on various dates from to resulting into the Minutes of Meeting/ Record Notes of Post Bid Discussions enclosed as APPENDIX (NOA)-1 with this Notification of Award.

2.0 AWARD OF CONTRACT AND ITS SCOPE

2.1 We confirm having accepted your Bid/Bid of the Joint Venture (JV) of M/s. (Lead Partner) and M/s. (Other Partner) *(Use as applicable)* (referred to at para 1.3 & 1.5 above) read in conjunction with all the specifications, terms & conditions of the Bidding Documents (referred



to at para 1.2, 1.2.1 & 1.2.2 [*modify as applicable*] above) and specific confirmations recorded in the Record Notes of Post Bid Discussions (referred to at para 1.6 above), and award on you/the JV (*use as applicable*) the ‘**Supply of Services Contract**’ (also referred to as the ‘Second Contract’) for performance of all other activities, as set forth in the documents, viz. (*Indicate brief scope of work*) for the (*insert name of Package alongwith name of the Project*)....

The scope of work under this Notification of Award (NOA) shall also include all such items which are not specifically mentioned in the Bidding Documents and/or your bid but are necessary for successful, efficient, safe and reliable operation of the goods, as detailed in the Bidding Documents unless otherwise specifically excluded in the Bidding Documents or in this Notification of Award.

- 2.1.1 You, the Lead Partner of the JV, along with M/s., the Other Partner of JV, shall be liable jointly and severally for the execution of the Contract in accordance with terms and conditions of the Contract. As per the Power of Attorney furnished in your favour by the Joint Venture, as enclosed with Bid Proposal of the JV, you shall act as the Partner In-charge (Lead Partner) of the above Joint Venture for execution of the Contract. (*This provision shall be included only in case the Bidder is a Joint Venture*).
- 2.2 The notification for award of Contract for Ex-works Supply of all equipment and materials including Type Testing to be conducted, as set forth in the documents, viz.

..... (*Indicate brief scope of work of the First Contract*)
.....

has been issued on you vide our NOA no. dated (hereinafter called the “ **Supply of Goods Contract**” or “First Contract”).

Notwithstanding the award of contract under two separate contracts in the aforesaid manner, you/the JV (*use as applicable*) shall be overall responsible to ensure the execution of both the contracts to achieve successful completion and taking over of the Goods under the package by the Purchaser as per the requirements stipulated in the Bidding documents. It is expressly understood and agreed by you/the JV (*use as applicable*) that any default or breach under the ‘First Contract’ shall automatically be deemed as a default or breach of this ‘Second Contract’ also and vice-versa, and any such default or breach or occurrence giving us a right to terminate the ‘First



Contract’, either in full or in part, and/or recover damages there under, shall give us an absolute right to terminate this Contract, at your/JV’s (*use as applicable*) risk, cost and responsibility, either in full or in part and/or recover damages under this ‘Second Contract’ as well. However, such default or breach or occurrence in the ‘First Contract’, shall not automatically relieve you/the JV (*use as applicable*) of any of your obligations under this ‘Second Contract’. It is also expressly understood and agreed by you/the JV (*use as applicable*) that the equipment/materials supplied by you/the JV (*use as applicable*) under the ‘First Contract’, **when inter-alia transported (to be suitably modified in case of Supply-cum-supervision packages)** by you/the JV (*use as applicable*) under this ‘Second Contract’ shall give satisfactory performance in accordance with the provisions of the Contract.

3.0 **CONTRACT PRICE**

3.1 The total Contract Price for the entire scope of work under this Contract shall be (*Specify the currency and the amount in figures & words*) as per the following break-up:

| Sl. No. | Price Component | Amount |
|--|--|--------|
| 1. | Inland/Local Transportation, Insurance & Loading Charges, In-transit | |
| 2. | Supervision Charges (<i>if applicable</i>) | |
| Total for Supply of Services Contract | | |

3.2 Notwithstanding the break-up of the Contract Price, the Contract shall, at all times, be construed as a single source responsibility Contract and any breach in any part of the Contract shall be treated as a breach of the entire Contract.

4.0 You/The JV (*use as applicable*) are/is required to furnish at the earliest a Performance Security(ies), as per the Bidding Documents, for an amount of (*Specify the value*) i.e. equal to 3% (Three percent) of the Contract Price, and valid upto and including and any other securities as per the Bidding Documents.

(In case any other performance security is required to be furnished, the same is to be mentioned here)



- 5.0 All the bank guarantees shall be furnished from an eligible bank as described in the Bidding Documents.
- 6.0 The delivery schedule for the supply of goods under the contract shall be construed from the date of issue of this Notification of Award for all contractual purposes as per below:

| Commencement of Delivery (Ex-works) | Completion of delivery (Site) | Approx. rate of supply (This column shall be applicable for Insulator & Conductor Packages only) |
|--|--|--|
| months from the date of Notification of Award | months from the date of Notification of Award | Total quantity equally distributed over the total delivery period. |

- 8.0 This Notification of Award constitutes formation of the Contract and comes into force with effect from the date of issuance of this Notification of Award.
- 9.0 You shall enter into a Contract Agreement with us within twenty-eight (28) days from the date of this Notification of Award.
- 10.0 This Notification of Award is being issued to you in duplicate. We request you to return its duplicate copy duly signed and stamped on each page including the enclosed Appendix as a token of your acknowledgement.

Please take the necessary action to commence the work and confirm action.
Yours faithfully,

For and on behalf of
.....(Name of the Purchaser).....
(Authorised Signatory)

Enclosures:

APPENDIX (NOA)-1 - Record Notes of Post - Bid Discussions held on various dates from to



[Alternative – 2: Applicable wherein the Supplier is an Foreign (i.e. Indian) Firm]

4a. FORM OF 'NOTIFICATION OF AWARD OF CONTRACT' FOR SUPPLY OF GOODS FROM ABROAD

Ref. No. :

Date :

.....(insert Contractor's Name & Address).....

.....

.....

.....

[in case of Joint Venture, the aforesaid details shall be of the Lead Partner and the following shall also be included:

(Lead Partner of the Joint Venture of M/s. and M/s.)]

Attn : Mr.....

Sub. : Notification of Award for **Supply of Goods from abroad Contract** for
..... (insert name of the Package) Specification No.:
..... Global Competitive Bidding. (Project Funding: Domestic).

Dear Sir,

1.0 REFERENCE

This has reference to the following:

1.1 Our Invitation for Bids (IFB) dated

1.2 Bidding documents for the subject package issued to you vide our letter Ref. No. dated, comprising the following:

a) Conditions of Contract Volume-I
(Document Code No.)

b) Technical Specifications Volume-II
(Document Code No.)

c) Bid Form, Price Schedules Volume-III & Technical Data Sheets
(Document Code No.)



- 1.2.1 Amendment/Errata No. to Bidding Documents issued to you vide our letter no. dated
(Applicable only if any Errata/Amendment to the Bidding Documents has been issued subsequently)
- 1.2.2 Clarifications to the Bidding Documents, pursuant to pre-bid conference held on, issued to you vide our letters no. dated
(Use as applicable)

(Applicable only if any clarification to the Bidding Documents has been issued subsequently)

(INCLUDE AS FURTHER SUB-PARAGRAPHS ANY OTHER CORRESPONDENCE MADE TO THE BIDDER AFTER ISSUANCE OF BIDDING DOCUMENTS UP TO BID OPENING)

- 1.3 First envelope of your Bid submitted/the Bid submitted by the Joint Venture (JV) of M/s. (Lead Partner) and M/s. (Other Partner) for the subject package under Proposal reference no. dated was opened on (Use as applicable)
- 1.4 Intimation for Opening of Second Envelope issued to you vide our letter no. dated
- 1.5 Second Envelope of your Bid/the Bid by the Joint Venture (JV) of M/s. (Lead Partner) and M/s. (Other Partner) under proposal reference no. dated was opened on.....(Use as applicable)
- 1.6 Post bid discussions we had with you on various dates from to resulting into the Minutes of Meeting/ Record Notes of Post Bid Discussions enclosed as APPENDIX (NOA)-1 with this Notification of Award.

2.0 AWARD OF CONTRACT AND ITS SCOPE

- 2.1 We confirm having accepted your Bid/Bid of the Joint Venture (JV) of M/s. (Lead Partner) and M/s. (Other Partner) (Use as applicable) (referred to at para 1.3 & 1.5 above) read in conjunction with all the specifications, terms & conditions of the Bidding Documents (referred to at para 1.2, 1.2.1 & 1.2.2 [modify as applicable] above) and specific confirmations recorded in the Record Notes of Post Bid Discussions (referred to at para 1.4 above), and award on you/the JV(use as applicable) the



‘Supply of Goods from abroad Contract’ (also referred to as the ‘First Contract’) covering inter-alia CIP Entry Border Point supply of all Plant and Equipment including mandatory Spares and Type Testing to be conducted abroad, required for the complete execution of the (insert name of Package alongwith name of the Project), as detailed in the documents referred hereinabove. The scope of work inter-alia includes the following:
..... (*Indicate brief Scope of Work*)

The scope of work under this Notification of Award (NOA) shall also include all such items which are not specifically mentioned in the Bidding Documents and/or your bid but are necessary for the successful completion of your scope under the Contract for the construction of (*insert name of Package alongwith name of the Project*), unless otherwise specifically excluded in the Bidding Documents or in this NOA.

- 2.1.1 You, the Lead Partner of the JV, along with M/s., the Other Partner of JV, shall be liable jointly and severally for the execution of the Contract in accordance with terms and conditions of the Contract. As per the Power of Attorney furnished in your favour by the Joint Venture, as enclosed with Bid Proposal of the JV, you shall act as the Partner In-charge (Lead Partner) of the above Joint Venture for execution of the Contract. (*This provision shall be included only in case the Bidder is a Joint Venture*)
- 2.2 The notification for award of Contract for performance of all other activities, as set forth in the Bidding Documents, viz.

..... (*Indicate brief scope of work of the Second Contract*)
.....

has been issued on you vide our NOA no. dated (hereinafter called the “Second Contract” or “ **Supply of Services from within Nepal Contract**”).

Notwithstanding the award of work under two separate Contracts in the aforesaid manner, you/the JV (*use as applicable*) shall be overall responsible to ensure the execution of both the Contracts to achieve successful completion and taking over of the Goods under the package by the Purchaser as per the requirements stipulated in the Bidding Documents. It is expressly understood and agreed by you/the JV (*use as applicable*) that any default or breach under the ‘Second Contract’ shall automatically be deemed as a default or breach of this ‘First Contract’ also and vice-versa, and any such default or breach or occurrence giving us a right to terminate the ‘Second



Contract', either in full or in part, and/or recover damages there under, shall give us an absolute right to terminate this Contract, at your/JV's (*use as applicable*) risk, cost and responsibility, either in full or in part and/or recover damages under this 'First Contract' as well. However, such default or breach or occurrence in the 'Second Contract', shall not automatically relieve you/the JV (*use as applicable*) of any of your/JV's (*use as applicable*) obligations under this 'First Contract'. It is also expressly understood and agreed by you/the JV (*use as applicable*) that the equipment/materials supplied by you/the JV (*use as applicable*) under this 'First Contract', when **inter-alia transported to site (to be suitably modified in case of Supply-cum-supervision packages)** by you under the 'Second Contract' shall give satisfactory performance in accordance with the provisions of the Contract.

3.0 **CONTRACT PRICE**

3.1 The total Contract Price for the entire scope of work under this Contract shall be (*Specify the currency and the amount in figures & words*) as per the following break-up:

| Sl. No. | Price Component | Amount |
|---|----------------------------------|--------|
| 1. | CIP Entry Border Price component | |
| 2. | Type Test Charges | |
| Total for Supply of Goods from abroad Contract | | |

3.2 Notwithstanding the break-up of the Contract Price, the Contract shall, at all times, be construed as a single source responsibility Contract and any breach in any part of the Contract shall be treated as a breach of the entire Contract.

4.0 You/The JV (*use as applicable*) are/is required to furnish at the earliest a Performance Security(ies), as per the Bidding Documents, for an amount of (*Specify the value*) i.e. equal to 3% (Three percent) of the Contract Price, and valid upto and including and any other securities as per the Bidding Documents.

(In case any other performance security is required to be furnished, the same is to be mentioned here)

5.0 For release of advance payment (admissible as per the bidding documents) equal to% of the CIP Entry Border Price component of the Contract Price, you are, inter-alia, required to furnish a Bank Guarantee for **[110% (one hundred ten percent) of the amount of Advance]**. The validity of the Advance Bank Guarantee shall be up to and including Further, please note that furnishing of all the Contract Performance Securities under the 'First Contract' and 'Second Contract' shall be one of the conditions precedent to release of advance under this Contract.



- 6.0 All the bank guarantees shall be furnished from an eligible bank as described in the Bidding Documents.
- 7.0 The delivery schedule for the supply of goods under the contract shall be construed from the date of issue of this Notification of Award for all contractual purposes as per below:

| Commencement of Delivery (Ex-works) | Completion of delivery (Site) | Approx. rate of supply (This column shall be applicable for Insulator & Conductor Packages only) |
|--|--|--|
| months from the date of Notification of Award | months from the date of Notification of Award | Total quantity equally distributed over the total delivery period. |

- 8.0 This Notification of Award constitutes formation of the Contract and comes into force with effect from the date of issuance of this Notification of Award.
- 9.0 You shall enter into a Contract Agreement with us within twenty-eight (28) days from the date of this Notification of Award.
- 10.0 This Notification of Award is being issued to you in duplicate. We request you to return its duplicate copy duly signed and stamped on each page including the enclosed Appendix as a token of your acknowledgement.

Please take the necessary action to commence the work and confirm action.

Yours faithfully,

For and on behalf of

.....(Name of the Employer).....

(Authorised Signatory)

Enclosures:

APPENDIX (NOA)-1 - Record Notes of Post - Bid Discussions held on various dates from to



4b.FORM OF 'NOTIFICATION OF AWARD OF CONTRACT' FOR SUPPLY OF SERVICES FROM WITHIN NEPAL

Ref. No. :

Date :

.....(insert Contractor's Name & Address).....

.....

.....

.....

[in case of Joint Venture, the aforesaid details shall be of the Lead Partner and the following shall also be included:

(Lead Partner of the Joint Venture of M/s. and M/s.)]

Attn: Mr.....

Sub. : Notification of Award for **Supply of Services from within Nepal**
Contract for (insert name of the Package) Specification No.:
..... Global Competitive Bidding. (Project Funding: Domestic).

Dear Sir,

1.0 REFERENCE



This has reference to the following:

1.1 Our Invitation for Bids (IFB) dated

1.2 Bidding documents for the subject package issued to you vide our letter Ref. No. dated, comprising the following:

a) Conditions of Contract Volume-I
(Document Code No.)

b) Technical Specifications Volume-II
(Document Code No.)

c) Bid Form, Price Schedules Volume-III & Technical Data Sheets
(Document Code No.)



1.2.1 Amendment/Errata No. to Bidding Documents issued to you vide our letter no. dated
(Applicable only if any Errata/Amendment to the Bidding Documents has been issued subsequently)

1.2.2 Clarifications to the Bidding Documents, pursuant to pre-bid conference held on, issued to you vide our letters no. dated *(Use as applicable)*

(Applicable only if any clarification to the Bidding Documents has been issued subsequently)

(INCLUDE AS FURTHER SUB-PARAGRAPHS ANY OTHER CORRESPONDENCE MADE TO THE BIDDER AFTER ISSUANCE OF BIDDING DOCUMENTS UP TO BID OPENING)

1.3 First envelope of your Bid submitted/the Bid submitted by the Joint Venture (JV) of M/s. (Lead Partner) and M/s. (Other Partner) for the subject package under Proposal reference no. dated was opened on *(Use as applicable)*

1.4 Intimation for Opening of Second Envelope issued to you vide our letter no. dated

1.5 Second Envelope of your Bid/the Bid by the Joint Venture (JV) of M/s. (Lead Partner) and M/s. (Other Partner) under proposal reference no. dated was opened on.....*(Use as applicable)*

1.6 Post bid discussions we had with you on various dates from to resulting into the Minutes of Meeting/ Record Notes of Post Bid Discussions enclosed as APPENDIX (NOA)-1 with this Notification of Award.

2.0 AWARD OF CONTRACT AND ITS SCOPE

2.1 We confirm having accepted your Bid/Bid of the Joint Venture (JV) of M/s. (Lead Partner) and M/s. (Other Partner) *(Use as applicable)* (referred to at para 1.3 & 1.5 above) read in conjunction with all the specifications, terms & conditions of the Bidding Documents



(referred to at para 1.2, 1.2.1 & 1.2.2 [modify as applicable] above) and specific confirmations recorded in the Record Notes of Post Bid Discussions (referred to at para 1.4 above), and award on you/the JV(use as applicable) the ‘**Supply of Services from within Nepal Contract**’ (also referred to as the ‘Second Contract’) for performance of all other activities, as set forth in the documents, viz. (Indicate brief scope of work) for the (insert name of Package alongwith name of the Project)....

The scope of work under this Notification of Award (NOA) shall also include all such items which are not specifically mentioned in the Bidding Documents and/or your bid but are necessary for the successful completion of your scope under the Contract for the construction of (*insert name of Package alongwith name of the Project*), unless otherwise specifically excluded in the Bidding Documents or in this NOA.

2.1.1 You, the Lead Partner of the JV, along with M/s., the Other Partner of JV, shall be liable jointly and severally for the execution of the Contract in accordance with terms and conditions of the Contract. As per the Power of Attorney furnished in your favour by the Joint Venture, as enclosed with Bid Proposal of the JV, you shall act as the Partner In-charge (Lead Partner) of the above Joint Venture for execution of the Contract. (*This provision shall be included only in case the Bidder is a Joint Venture*)

2.2 The notification for award of Contract for CIP Entry Border Point Supply of all equipment and materials including Type Testing to be conducted, as set forth in the - documents, viz.

.....(*Indicate brief scope of work of the First Contract*)
.....

has been issued on you vide our NOA no. dated (hereinafter called the “ **Supply of Goods from abroad Contract**” or “First Contract”).

Notwithstanding the award of contract under two separate contracts in the aforesaid manner, you/the JV(*use as applicable*) shall be overall responsible to ensure the execution of both the contracts to achieve successful completion and taking over of the Goods under the package by the Purchaser as per the requirements stipulated in the Bidding documents.It is expressly understood and agreed by you/the JV(*use as*



applicable) that any default or breach under the 'First Contract' shall automatically be deemed as a default or breach of this 'Second Contract' also and vice-versa, and any such default or breach or occurrence giving us a right to terminate the 'First Contract', either in full or in part, and/or recover damages there under, shall give us an absolute right to terminate this Contract, at your/JV's (*use as applicable*) risk, cost and responsibility, either in full or in part and/or recover damages under this 'Second Contract' as well. However, such default or breach or occurrence in the 'First Contract', shall not automatically relieve you/the JV (*use as applicable*) of any of your obligations under this 'Second Contract'. It is also expressly understood and agreed by you/the JV (*use as applicable*) that the equipment/materials supplied by you/the JV (*use as applicable*) under the 'First Contract', **when inter-alia transported (to be suitably modified in case of Supply-cum-supervision packages)** by you/the JV (*use as applicable*) under this 'Second Contract' shall give satisfactory performance in accordance with the provisions of the Contract.

3.0 CONTRACT PRICE

3.1 The total Contract Price for the entire scope of work under this Contract shall be (*Specify the currency and the amount in figures & words*) as per the following break-up:

| Sl. No. | Price Component | Amount |
|--|---|--------|
| 1.1 | Port handling and custom clearance of supplies from abroad | |
| 1.2 | Local/Inland Transportation, In-transit Insurance and loading Charges | |
| 2. | Supervision Charges | |
| Total for Supply of Services from within Nepal Contract | | |

3.2 Notwithstanding the break-up of the Contract Price, the Contract shall, at all times, be construed as a single source responsibility Contract and any breach in any part of the Contract shall be treated as a breach of the entire Contract.

4.0 You/The JV (*use as applicable*) are/is required to furnish at the earliest a Performance Security(ies), as per the Bidding Documents, for an amount of (*Specify the value*) i.e. equal to 3% (Three percent) of the



Contract Price, and valid upto and including and any other securities as per the Bidding Documents.

(In case any other performance security is required to be furnished, the same is to be mentioned here)

- 5.0 All the bank guarantees shall be furnished from an eligible bank as described in the Bidding Documents.
- 6.0 The delivery schedule for the supply of goods under the contract shall be construed from the date of issue of this Notification of Award for all contractual purposes as per below:

| Commencement of Delivery (Ex-works) | Completion of delivery (Site) | Approx. rate of supply <i>(This column shall be applicable for Insulator & Conductor Packages only)</i> |
|--|--|---|
| months from the date of Notification of Award | months from the date of Notification of Award | Total quantity equally distributed over the total delivery period. |

- 7.0 This Notification of Award constitutes formation of the Contract and comes into force with effect from the date of issuance of this Notification of Award.
- 8.0 You shall enter into a Contract Agreement with us within twenty-eight (28) days from the date of this Notification of Award.
- 9.0 This Notification of Award is being issued to you in duplicate. We request you to return its duplicate copy duly signed and stamped on each page including the enclosed Appendix as a token of your acknowledgement.

Please take the necessary action to commence the work and confirm action.

Yours faithfully,

For and on behalf of

.....(Name of the Employer).....

(Authorised Signatory)

Enclosures:

APPENDIX (NOA) – 1 - Record Notes of Post - Bid Discussions held on various dates from to



5a. FORM OF CONTRACT AGREEMENT

[Alternative – 1a: Applicable for packages wherein the Supplier is an Nepalese Firm]

SUPPLY OF GOODS CONTRACT AGREEMENT BETWEEN (*Name of Purchaser*) AND M/s. (*Name of Supplier*)/JOINT VENTURE (JV) OF M/s. (*Name of Lead Partner*).... (THE LEAD PARTNER OF THE JV) AND M/s.(*Name of Other Partner*)..... (THE PARTNER OF THE JV) [*Use as applicable*]

THIS CONTRACT AGREEMENT No. (also referred to as 'the Contract') is made on the day of 20.....

BETWEEN

(1) (*Name of Purchaser*)..... a company incorporated under the laws of Companies Act 1956 and having its Registered Office at(*registered address of the Purchaser*) and its Corporate Office at(*address of the Purchaser*)..... (hereinafter called "the Purchaser" and also referred to as ".....(*insert abbreviated name of the Purchaser*)")

and

(2) M/s (*Name of Supplier*), a company incorporated under the laws of Companies Act 1956 and having its Principal place of business at(*Address of Supplier*) and Registered Office at(*Registered address of Supplier*) (hereinafter called "the Supplier" and also referred to as ".....(*insert abbreviated name of the Supplier*)")

Or

Joint Venture (JV) of M/s (*Name of Lead Partner*) (the Lead Partner of JV), a company incorporated under the laws of Companies Act 1956 and having its Principal place of business at(*Address of Lead Partner*) and Registered Office at(*Registered address of Lead Partner*) and M/s (*Name of Other Partner*) (the Partner of JV), a company incorporated under the laws of Companies Act 1956 and having its Principal place of business at



.....(Address of Other Partner) and Registered Office at
.....(Registered address of Other Partner) (hereinafter called
"the Supplier" and also referred to as "Joint Venture"/the 'JV'")
(Applicable only in case of Joint Venture)

WHEREAS the Purchaser desires to engage the Supplier for the Ex-works supply of goods including Type Testing to be conducted inter-alia including (Indicate brief scope of work) for the complete execution of the (insert name of Package alongwith name of the Project)..... as detailed in the Contract Document, and the Supplier has agreed to such engagement upon and subject to the terms and conditions hereinafter appearing.

NOW IT IS HEREBY AGREED as follows:

Article 1. Contract Documents

1.1 Contract Documents (Reference GCC Clause 2.2)

The following documents shall constitute the Contract between the Purchaser and the Supplier, and each shall be read and construed as an integral part of the Contract:

VOLUME – A

1. This Contract Agreement and the Appendices thereto.
2. Notification of Award Ref. No. dated

VOLUME – B

3. "Bidding Documents" comprising of the following:

- (a) Volume –I of Bidding Documents (Document Code No.:), read in conjunction with Amendments to to the Bidding Documents.
- (b) Volume –II of Bidding Documents (Document Code No.:) comprising of Technical Specifications.

VOLUME – C

4. Bid Submitted by the Supplier.



(Only relevant extracts are attached herewith for easy reference. Should the circumstances warrant, the original Bid along with the enclosures thereof, shall be referred to.).

1.2 Order of Precedence (Reference GCC Clause 2)

In the event of any ambiguity or conflict between the Contract Documents listed above, the order of precedence shall be the order in which the Contract Documents are listed in Article 1.1 (Contract Documents) above.

1.3 Definitions (Reference GCC Clause 1/SCC Clause 1)

1.3.1 Capitalized words and phrases used herein shall have the same meanings as are ascribed to them in the General Conditions of Contract/Special Conditions of Contract.

Article 2. Contract Price and Terms of Payment

2.1 Contract Price (Reference GCC Clause 7)

The Purchaser hereby agrees to pay to the Supplier the Contract Price in consideration of the performance by the Supplier of its obligations hereunder. The Contract Price shall be the aggregate of (*amount of currency in words*) (*amount in figures*)), or such other sums as may be determined in accordance with the terms and conditions of the Contract. The break-up of the Contract price is as under:

| Sl. No. | Price Component | Amount |
|---|--------------------------|--------|
| 1. | Ex-Works Price component | |
| 2. | Type Test Charges | |
| Total for Supply of Goods Contract | | |

The detailed break-up of Contract Price is given in the relevant Appendices hereto.

2.2 Terms of Payment (Reference GCC Clause 8)

The terms and procedures of payment according to which the Purchaser will reimburse the Supplier are given in Appendix 1 (Terms and Procedures of Payment) hereto.

Article 3. Effective Date for Determining the Delivery Schedule

3.1 Effective Date (Reference GCC Clause 1)

The Delivery Schedule shall be determined from the date of the Notification of Award i.e., from

Article 4. Appendices



The Appendices listed in the List of Appendices, as mentioned below, shall be deemed to form an integral part of this Contract Agreement.

Reference in the Contract to any Appendix shall mean the Appendices attached hereto, and the Contract shall be read and construed accordingly.

List of Appendices

| | |
|--------------------------|--|
| Appendix 1 | Terms and Procedures of Payment |
| Appendix 2 | Price Adjustment |
| Appendix 3 | Insurance Requirements |
| Appendix 4 | Delivery Schedule |
| Appendix 5 | List of Approved SubSuppliers |
| Appendix 6 | List of Document for Approval or Review |
| Appendix 7 | Guarantees, Liquidated Damages for Non-Performance |
| Appendix 8 | Contract Co-ordination Procedure |
| Appendix 9 [^] | Summary of Detailed Price Break-up |
| Appendix 9A [^] | Detailed Price Break-up of Price |
| Appendix 9B [^] | Detailed Price Break-up of Charges |
| Appendix 10 [^] | Integrity Pact |

[[^] to be appended at the Stage of Contract Award.]

Article 5.

The Contract Agreement No. has also been made on the day of 20...., between the Purchaser and the Supplier for the Supply of Services Contract (hereinafter referred to as the "Second Contract") for the subject package which includes performance of all the services interalia including (*Indicate brief scope of work*) for the complete execution of the (*insert name of Package alongwith name of the Project*).....

Notwithstanding the award of contract under two separate contracts in the aforesaid manner, the Supplier shall be overall responsible to ensure the execution of both the contracts to achieve successful completion and taking over of the Goods by the Purchaser as per the requirements stipulated in the Contract. It is expressly understood and agreed by the Supplier that any default or breach under the 'Second Contract' shall automatically be deemed as a default or breach of this 'First Contract' also and vice-versa and any such breach or occurrence or default giving the Purchaser a right to terminate the 'Second Contract' either in full or in part, and/or recover damages there under that Contract, shall give the Purchaser an absolute right to terminate this Contract at the Supplier's risk, cost and responsibility, either in full or in part and /or recover damages under this 'First Contract' as well. However, such breach or default or occurrence in the 'Second



Contract' shall not automatically relieve the Supplier of any of its responsibility/ obligations under this 'First Contract'. It is also expressly understood and agreed by the Supplier that the Goods supplied by the Supplier under this 'First Contract' when **inter-alia Transported to site (to be suitably modified in case of Supply-cum-supervision packages)** by the Supplier under the 'Second Contract' shall give satisfactory performance in accordance with the provisions of the Contract.

Article 6. **(applicable only for package CD03)**

Integrity Pact

Under the Integrity Pact Program (IPP), a **panel of Independent External Monitors (IEMs) comprising Sh. S.P. Srivastava, IPS (Retd.) & Smt. Archana Pandey Tiwari, IRS (Retd.) has been appointed by CVC.** Correspondence, if any, to the **panel of IEMs** be addressed to the following:

Independent External Monitor

| Sl. No. | Name of IEMs | Address of IEMs |
|---------|--|--|
| 1 | Sh. S.P. Srivastava, IPS (Retd.) | 1/125, Vineet Khand, Gomtinagar, Lucknow, UP-226010 Email: sps_ips@yahoo.com |
| 2 | Smt. Archana Pandey Tiwari, IRS (Retd.) | C-32, Nangal Dewat, Vasant Kunj, New Delhi-110070 Email: ampandey2001@yahoo.com |

IN WITNESS WHEREOF the Purchaser and the Supplier have caused this Agreement to be duly executed by their duly authorized representatives the day and year first above written.

| | |
|---|--|
| <p>Signed by for and on behalf of the Purchaser</p> <p>.....</p> <p>Signature</p> <p>.....</p> <p>Title</p> <p>in the presence of</p> | <p>Signed by for and on behalf of the Supplier</p> <p>.....</p> <p>Signature</p> <p>.....</p> <p>Title</p> <p>in the presence of</p> |
|---|--|



5b. FORM OF CONTRACT AGREEMENT

SUPPLY OF SERVICES CONTRACT AGREEMENT BETWEEN (*Name of Purchaser*) AND M/s. (*Name of Supplier*)/JOINT VENTURE (JV) OF M/s. (*Name of Lead Partner*).... (THE LEAD PARTNER OF THE JV) AND M/s.(*Name of Other Partner*)..... (THE PARTNER OF THE JV) [*Use as applicable*]

THIS CONTRACT AGREEMENT No. (also referred to as 'the Contract') is made on the day of 20.....

BETWEEN

(1) (*Name of Purchaser*)..... a company incorporated under the laws of Companies Act 1956 and having its Registered Office at(*registered address of the Purchaser*) and its Corporate Office at(*address of the Purchaser*)..... (hereinafter called "the Purchaser" and also referred to as ".....(*insert abbreviated name of the Purchaser*)")

and

(2) M/s (*Name of Supplier*), a company incorporated under the laws of Companies Act 1956 and having its Principal place of business at(*Address of Supplier*) and Registered Office at(*Registered address of Supplier*) (hereinafter called "the Supplier" and also referred to as ".....(*insert abbreviated name of the Supplier*)")

Or

Joint Venture (JV) of M/s (*Name of Lead Partner*) (the Lead Partner of JV), a company incorporated under the laws of Companies Act 1956 and having its Principal place of business at(*Address of Lead Partner*) and Registered Office at(*Registered address of Lead Partner*) and M/s (*Name of Other Partner*) (the Partner of JV), a company incorporated under the laws of Companies Act 1956 and having its Principal place of business at(*Address of Other Partner*) and Registered Office at(*Registered address of Other*



Partner) (hereinafter called "the Supplier" and also referred to as "Joint Venture"/the 'JV'")
(Applicable only in case of Joint Venture)

WHEREAS the Purchaser desires to engage the Supplier for all the services inter-alia including (*Indicate brief scope of work*) for the complete execution of the (*insert name of Package alongwith name of the Project*)..... as detailed in the Contract Document, and the Supplier has agreed to such engagement upon and subject to the terms and conditions hereinafter appearing.

NOW IT IS HEREBY AGREED as follows:

Article 1. Contract Documents

1.1 Contract Documents (Reference GCC Clause 2.2)

The following documents shall constitute the Contract between the Purchaser and the Supplier, and each shall be read and construed as an integral part of the Contract:

VOLUME – A

1. This Contract Agreement and the Appendices thereto.
2. Notification of Award Ref. No. dated

VOLUME – B

3. "Bidding Documents" comprising of the following:

- (a) Volume –I of Bidding Documents (Document Code No.:), read in conjunction with Amendments to to the Bidding Documents.
- (b) Volume –II of Bidding Documents (Document Code No.:) comprising of Technical Specifications.

VOLUME – C

4. Bid Submitted by the Supplier.



(Only relevant extracts are attached herewith for easy reference. Should the circumstances warrant, the original Bid along with the enclosures thereof, shall be referred to.).

1.2 Order of Precedence (Reference GCC Clause 2)

In the event of any ambiguity or conflict between the Contract Documents listed above, the order of precedence shall be the order in which the Contract Documents are listed in Article 1.1 (Contract Documents) above.

1.3 Definitions (Reference GCC Clause 1/SCC Clause 1)

1.3.1 Capitalized words and phrases used herein shall have the same meanings as are ascribed to them in the General Conditions of Contract/Special Conditions of Contract.

Article 2. Contract Price and Terms of Payment

2.1 Contract Price (Reference GCC Clause 7)

The Purchaser hereby agrees to pay to the Supplier the Contract Price in consideration of the performance by the Supplier of its obligations hereunder. The Contract Price shall be the aggregate of (*amount of currency in words*) (*amount in figures*)), or such other sums as may be determined in accordance with the terms and conditions of the Contract. The break-up of the Contract price is as under:

| Sl. No. | Price Component | Amount |
|--|---|--------|
| 1. | Inland Transportation, In-transit Insurance, Loading Charges | |
| 2. | Supervision Charges (<i>if applicable</i>) | |
| Total for Supply of Services Contract | | |

The detailed break-up of Contract Price is given in the relevant Appendices hereto.

2.2 Terms of Payment (Reference GCC Clause 8)

The terms and procedures of payment according to which the Purchaser will reimburse the Supplier are given in Appendix 1 (Terms and Procedures of Payment) hereto.

Article 3. Effective Date for Determining the Delivery Schedule



3.1 Effective Date (Reference GCC Clause 1)

The Delivery Schedule shall be determined from the date of the Notification of Award i.e., from

Article 4. Appendices

The Appendices listed in the List of Appendices, as mentioned below, shall be deemed to form an integral part of this Contract Agreement.

Reference in the Contract to any Appendix shall mean the Appendices attached hereto, and the Contract shall be read and construed accordingly.

List of Appendices

- Appendix 1 Terms and Procedures of Payment
 - Appendix 2 Price Adjustment
 - Appendix 3 Insurance Requirements
 - Appendix 4 Delivery Schedule
 - Appendix 5 List of Approved SubSuppliers
 - Appendix 6 List of Document for Approval or Review
 - Appendix 7 Guarantees, Liquidated Damages for Non-Performance
 - Appendix 8 Contract Co-ordination Procedure
 - Appendix 9[^] Summary of Detailed Price Break-up
 - Appendix 9A[^] Detailed Price Break-up of Charges
 - Appendix 10[^] Integrity Pact
- [[^] to be appended at the Stage of Contract Award.]

Article 5.

The Contract Agreement No. has also been made on the day of 20...., between the Purchaser and the Supplier for the Supply of Goods Contract (hereinafter referred to as the "First Contract") for the subject package which includes Ex-works supply of Goods including Type Testing to be conducted interalia including (*Indicate brief scope of work*) for the complete execution of the (*insert name of Package alongwith name of the Project*).....

Notwithstanding the award of contract under two separate contracts in the aforesaid manner, the Supplier shall be overall responsible to ensure the execution of both the contracts to achieve successful completion and taking over of the Goods by the Purchaser as per the requirements stipulated in the Contract. It is expressly understood and agreed by the Supplier that any default or breach under the 'First



Contract' shall automatically be deemed as a default or breach of this 'Second Contract' also and vice-versa and any such breach or occurrence or default giving the Purchaser a right to terminate the 'First Contract' either in full or in part, and/or recover damages there under that Contract, shall give the Purchaser an absolute right to terminate this Contract at the Supplier's risk, cost and responsibility, either in full or in part and /or recover damages under this 'Second Contract' as well. However, such breach or default or occurrence in the 'First Contract' shall not automatically relieve the Supplier of any of its responsibility/ obligations under this 'Second Contract'. It is also expressly understood and agreed by the Supplier that the Goods supplied by the Supplier under the 'First Contract' **when inter-alia transported to site (to be suitably modified in case of Supply-cum-supervision packages)** by the Supplier under this 'Second Contract' shall give satisfactory performance in accordance with the provisions of the Contract.

Article 6. **(applicable only for package CD03)**

Integrity Pact

Under the Integrity Pact Program (IPP), **a panel of Independent External Monitors (IEMs) comprising Sh. S.P. Srivastava, IPS (Retd.) & Smt. Archana Pandey Tiwari, IRS (Retd.) has been appointed by CVC.** Correspondence, if any, to the panel of IEMs be addressed to the following:

Independent External Monitor

| Sl. No. | Name of IEMs | Address of IEMs |
|---------|---|--|
| 1 | Sh. S.P. Srivastava, IPS (Retd.) | 1/125, Vineet Khand, Gomtinagar, Lucknow, UP-226010 Email: sps_ips@yahoo.com |
| 2 | Smt. Archana Pandey Tiwari, IRS (Retd.) | C-32, Nangal Dewat, Vasant Kunj, New Delhi-110070 Email: ampandey2001@yahoo.com |

IN WITNESS WHEREOF the Purchaser and the Supplier have caused this Agreement to be duly executed by their duly authorized representatives the day and year first above written.

| | |
|--|---|
| Signed by for and on behalf of the Purchaser Signature Title in the presence of | Signed by for and on behalf of the Supplier Signature Title in the presence of |
|--|---|



[Alternative – 2a: Applicable for packages wherein the Supplier is an Indian Firm]

SUPPLY OF GOODS FROM ABROAD CONTRACT AGREEMENT BETWEEN
..... (Name of Purchaser) AND M/s. (Name of Supplier)/JOINT VENTURE (JV) OF M/s. (Name of Lead Partner).... (THE LEAD PARTNER OF THE JV) AND M/s.(Name of Other Partner)..... (THE PARTNER OF THE JV) [Use as applicable]

THIS CONTRACT AGREEMENT No. (also referred to as 'Supply of Goods from Abroad Contract/the First Contract') is made on the day of 20.....

BETWEEN

(1) (Name of Purchaser)..... a company incorporated under the laws of Companies Act 1956 and having its Registered Office at(registered address of the Purchaser) and its Corporate Office at(address of the Purchaser)..... (hereinafter called "the Purchaser" and also referred to as ".....(insert abbreviated name of the Purchaser)")

and

(2) M/s (Name of Supplier), a company incorporated under the laws of(Country of Supplier) and having its Principal place of business at(Address of Supplier) and Registered Office at(Registered address of Supplier) (hereinafter called "the Supplier" and also referred to as ".....(insert abbreviated name of the Supplier)")

or

Joint Venture (JV) of M/s (Name of Lead Partner) (the Lead Partner of JV), a company incorporated under the laws of(Country of Lead Partner) and having its Principal place of business at(Address of Lead Partner) and Registered Office at(Registered address of Lead Partner) and M/s (Name of Other Partner) (the Partner of JV), a company incorporated under the laws of(Country of Other Partner) and having its Principal place of business at(Address of Other Partner) and Registered Office at(Registered address of Other Partner) (hereinafter called "the Supplier" and also referred to as "Joint Venture"/the 'JV'")
(Applicable only in case of Joint Venture)



WHEREAS the Purchaser desires to engage the Supplier for the CIP Entry Border supply of all equipment and materials including Type Testing to be conducted outside Nepal inter-alia including (*Indicate brief scope of work*) for the complete execution of the (*insert name of Package alongwith name of the Project*)..... as detailed in the Contract Document , and the Supplier has agreed to such engagement upon and subject to the terms and conditions hereinafter appearing.

NOW IT IS HEREBY AGREED as follows:

Article 1. Contract Documents

1.1 Contract Documents (Reference GCC Clause 2.2)

The following documents shall constitute the Contract between the Purchaser and the Supplier, and each shall be read and construed as an integral part of the Contract:

VOLUME – A

1. This Contract Agreement and the Appendices thereto.
2. Notification of Award Ref. No. dated

VOLUME – B

3. “Bidding Documents” comprising of the following:

- (a) Volume –I of Bidding Documents (Document Code No.:), read in conjunction with Amendments to to the Bidding Documents.
- (b) Volume –II of Bidding Documents (Document Code No.:) comprising of Technical Specifications.

VOLUME – C

4. Bid Submitted by the Supplier.

(Only relevant extracts are attached herewith for easy reference. Should the circumstances warrant, the original Bid along with the enclosures thereof, shall be referred to.).

1.2 Order of Precedence (Reference GCC Clause 2)



In the event of any ambiguity or conflict between the Contract Documents listed above, the order of precedence shall be the order in which the Contract Documents are listed in Article 1.1 (Contract Documents) above.

1.3 Definitions (Reference GCC Clause 1/SCC Clause 1)

1.3.1 Capitalized words and phrases used herein shall have the same meanings as are ascribed to them in the General Conditions of Contract/Special Conditions of Contract.

Article 2. Contract Price and Terms of Payment

2.1 Contract Price (Reference GCC Clause 7)

The Purchaser hereby agrees to pay to the Supplier the Contract Price in consideration of the performance by the Supplier of its obligations hereunder. The Contract Price shall be the aggregate of (*amount of currency in words*) (*amount in figures*)), or such other sums as may be determined in accordance with the terms and conditions of the Contract. The break-up of the Contract price is as under:

| Sl. No. | Price Component | Amount |
|---|---------------------|--------|
| 1. | CIF Price component | |
| 2. | Type Test Charges | |
| Total for Supply of Goods from Abroad Contract | | |

The detailed break-up of Contract Price is given in the relevant Appendices hereto.

2.2 Terms of Payment (Reference GCC Clause 8)

The terms and procedures of payment according to which the Purchaser will reimburse the Supplier are given in Appendix 1 (Terms and Procedures of Payment) hereto.

Article 3. Effective Date for Determining Time for Completion

3.1 Effective Date (Reference GCC Clause 1)

The Time of Completion shall be determined from the date of the Notification of Award i.e., from



Article 4. Appendices

The Appendices listed in the List of Appendices, as mentioned below, shall be deemed to form an integral part of this Contract Agreement.

Reference in the Contract to any Appendix shall mean the Appendices attached hereto, and the Contract shall be read and construed accordingly.

List of Appendices

- Appendix 1 Terms and Procedures of Payment
- Appendix 2 Price Adjustment
- Appendix 3 Insurance Requirements
- Appendix 4 Time Schedule
- Appendix 5 List of Approved SubSuppliers
- Appendix 6 List of Document for Approval or Review
- Appendix 7 Guarantees, Liquidated Damages for Non-Performance
- Appendix 8 Contract Co-ordination Procedure
- Appendix 9[^] Summary of Detailed Price Break-up
- Appendix 9A[^] Detailed Price Break-up of Price
- Appendix 9B[^] Detailed Price Break-up of Charges
- Appendix 10[^] Integrity Pact.

[[^] to be appended at the Stage of Contract Award.]

Article 5.

The Contract Agreement No. has also been made on the day of 20...., between the Purchaser and the Supplier for the Supply of Services from within Nepal Contract (hereinafter referred to as the "Second Contract") for the subject package which includes performance of all the services interalia including (*Indicate brief scope of work*) for the complete execution of the (*insert name of Package alongwith name of the Project*).....

Notwithstanding the award of contract under two separate contracts in the aforesaid manner, the Supplier shall be overall responsible to ensure the execution of both the contracts to achieve successful completion and taking over of the Goods by the Purchaser as per the requirements stipulated in the Contract. It is expressly understood and agreed by the Supplier that any default or breach under the 'Second Contract' shall automatically be deemed as a default or breach of this 'First Contract' also and vice-versa and any such breach or occurrence or default giving the Purchaser a right to terminate the 'Second Contract' either in full or in part, and/or



recover damages there under that Contract, shall give the Purchaser an absolute right to terminate this Contract at the Supplier’s risk, cost and responsibility, either in full or in part and /or recover damages under this ‘First Contract’ as well. However, such breach or default or occurrence in the ‘Second Contract’ shall not automatically relieve the Supplier of any of its responsibility/ obligations under this ‘First Contract’. It is also expressly understood and agreed by the Supplier that the Goods supplied by the Supplier under this ‘First Contract’ when inter-alia Transported to site (to be suitably modified in case of Supply-cum-supervision packages) by the Supplier under the ‘Second Contract’ shall give satisfactory performance in accordance with the provisions of the Contract.

Article 6. (applicable only for package CD03)

Integrity Pact

Under the Integrity Pact Program (IPP), a panel of Independent External Monitors (IEMs) comprising Sh. S.P. Srivastava, IPS (Retd.) & Smt. Archana Pandey Tiwari, IRS (Retd.) has been appointed by CVC. Correspondence, if any, to the panel of IEMs be addressed to the following:

Independent External Monitor

| Sl. No. | Name of IEMs | Address of IEMs |
|---------|---|--|
| 1 | Sh. S.P. Srivastava, IPS (Retd.) | 1/125, Vineet Khand, Gomtinagar, Lucknow, UP-226010 Email: sps_ips@yahoo.com |
| 2 | Smt. Archana Pandey Tiwari, IRS (Retd.) | C-32, Nangal Dewat, Vasant Kunj, New Delhi-110070 Email: ampandey2001@yahoo.com |

IN WITNESS WHEREOF the Purchaser and the Supplier have caused this Agreement to be duly executed by their duly authorized representatives the day and year first above written.

Signed by for and
on behalf of the Purchaser

Signed by for and
on behalf of the Supplier

.....
Signature

.....
Signature

.....
Title

.....
Title

in the presence of

in the presence of



5. FORM OF CONTRACT AGREEMENT

[Alternative – 2b: Applicable for packages wherein the Supplier is an Indian Firm]

SUPPLY OF SERVICES FROM WITHIN NEPAL CONTRACT AGREEMENT
BETWEEN (Name of Purchaser) AND M/s.
(Name of Supplier)/JOINT VENTURE (JV) OF M/s. (Name of Lead
Partner).... (THE LEAD PARTNER OF THE JV) AND M/s.(Name of Other
Partner)..... (THE PARTNER OF THE JV) [Use as applicable]

THIS CONTRACT AGREEMENT No. (also referred to as '**Supply of Services from within Nepal** Contract/the Second Contract') is made on the day of 20.....

BETWEEN

(1) (Name of Purchaser)..... a company incorporated under the laws of Companies Act 1956 and having its Registered Office at(registered address of the Purchaser) and its Corporate Office at(address of the Purchaser)..... (hereinafter called "the Purchaser" and also referred to as ".....(insert abbreviated name of the Purchaser)")

and

(2) M/s (Name of Supplier), a company incorporated under the laws of(Country of Supplier) and having its Principal place of business at(Address of Supplier) and Registered Office at(Registered address of Supplier) (hereinafter called "the Supplier" and also referred to as ".....(insert abbreviated name of the Supplier)")

or

Joint Venture (JV) of M/s (Name of Lead Partner) (the Lead Partner of JV), a company incorporated under the laws of(Country of Lead Partner) and having its Principal place of business at(Address of Lead Partner) and Registered Office at(Registered address of Lead Partner) and M/s (Name of Other Partner) (the Partner of JV), a company incorporated under the laws of(Country of Other Partner) and having its Principal place of business at(Address of Other Partner) and Registered Office at(Registered address of Other Partner) (hereinafter called "the Supplier" and also referred to as "Joint Venture"/the 'JV'")
(Applicable only in case of Joint Venture)

WHEREAS the Purchaser desires to engage the Supplier for providing all the services inter-alia including (Indicate brief scope of work)



..... for the complete execution of the (*insert name of Package alongwith name of the Project*)..... as detailed in the Contract Document , and the Supplier has agreed to such engagement upon and subject to the terms and conditions hereinafter appearing.

NOW IT IS HEREBY AGREED as follows:

Article 1. Contract Documents

1.1 Contract Documents (Reference GCC Clause 2.2)

The following documents shall constitute the Contract between the Purchaser and the Supplier, and each shall be read and construed as an integral part of the Contract:

VOLUME – A

1. This Contract Agreement and the Appendices thereto.
2. Notification of Award Ref. No. dated

VOLUME – B

3. “Bidding Documents” comprising of the following:
 - (a) Volume –I of Bidding Documents (Document Code No.:), read in conjunction with Amendments to to the Bidding Documents.
 - (b) Volume –II of Bidding Documents (Document Code No.:) comprising of Technical Specifications.

VOLUME – C

4. Bid Submitted by the Supplier.

(Only relevant extracts are attached herewith for easy reference. Should the circumstances warrant, the original Bid along with the enclosures thereof, shall be referred to.)

1.2 Order of Precedence (Reference GCC Clause 2)

In the event of any ambiguity or conflict between the Contract Documents listed above, the order of precedence shall be the order in which the Contract Documents are listed in Article 1.1 (Contract Documents) above.

1.3 Definitions (Reference GCC Clause 1/SCC Clause 1)

1.3.1 Capitalized words and phrases used herein shall have the same meanings as are ascribed to them in the General Conditions of Contract/Special Conditions of Contract.

Article 2. Contract Price and Terms of Payment



2.1 Contract Price (Reference GCC Clause 7)

The Purchaser hereby agrees to pay to the Supplier the Contract Price in consideration of the performance by the Supplier of its obligations hereunder. The Contract Price shall be the aggregate of (*amount of currency in words*) (*amount in figures*)), or such other sums as may be determined in accordance with the terms and conditions of the Contract. The break-up of the Contract price is as under:

| Sl. No. | Price Component | Amount |
|---|---|--------|
| 1.1 | Port handling and custom clearance of supplies from abroad | |
| 1.2 | Local Transportation, Insurance and other Incidental Services | |
| 2. | Supervision Charges | |
| Total for Supply of Services from <i>within</i> Nepal Contract | | |

The detailed break-up of Contract Price is given in the relevant Appendices hereto.

2.2 Terms of Payment (Reference GCC Clause 8)

The terms and procedures of payment according to which the Purchaser will reimburse the Supplier are given in Appendix 1 (Terms and Procedures of Payment) hereto.

Article 3. Effective Date for Determining Time for Completion

3.1 Effective Date (Reference GCC Clause 1)

The Time of Completion shall be determined from the date of the Notification of Award i.e., from

Article 4. Appendices

The Appendices listed in the List of Appendices, as mentioned below, shall be deemed to form an integral part of this Contract Agreement.

Reference in the Contract to any Appendix shall mean the Appendices attached hereto, and the Contract shall be read and construed accordingly.

List of Appendices



- Appendix 1 Terms and Procedures of Payment
 - Appendix 2 Price Adjustment
 - Appendix 3 Insurance Requirements
 - Appendix 4 Time Schedule
 - Appendix 5 List of Approved SubSuppliers
 - Appendix 6 List of Document for Approval or Review
 - Appendix 7 Guarantees, Liquidated Damages for Non-Performance
 - Appendix 8 Contract Co-ordination Procedure
 - Appendix 9^ Summary of Detailed Price Break-up
 - Appendix 9A^ Detailed Price Break-up of Price
 - Appendix 9B^ Detailed Price Break-up of Charges
 - Appendix 10^ Integrity Pact.
- [^ to be appended at the Stage of Contract Award.]

Article 5.

The Contract Agreement No. has also been made on the day of 20...., between the Purchaser and the Supplier for the Supply of Goods from Abroad Contract (hereinafter referred to as the “First Contract”) for the subject package which includes CIP Entry Border Point supply of Goods including Type Testing to be conducted interalia including (*Indicate brief scope of work*) for the complete execution of the (*insert name of Package alongwith name of the Project*).....

Notwithstanding the award of contract under two separate contracts in the aforesaid manner, the Supplier shall be overall responsible to ensure the execution of both the contracts to achieve successful completion and taking over of the Goods by the Purchaser as per the requirements stipulated in the Contract. It is expressly understood and agreed by the Supplier that any default or breach under the ‘First Contract’ shall automatically be deemed as a default or breach of this ‘Second Contract’ also and vice-versa and any such breach or occurrence or default giving the Purchaser a right to terminate the ‘First Contract’ either in full or in part, and/or recover damages there under that Contract, shall give the Purchaser an absolute right to terminate this Contract at the Supplier’s risk, cost and responsibility, either in full or in part and /or recover damages under this ‘Second Contract’ as well. However, such breach or default or occurrence in the ‘First Contract’ shall not automatically relieve the Supplier of any of its responsibility/ obligations under this ‘Second Contract’. It is also expressly understood and agreed by the Supplier that the Goods supplied by the Supplier under the ‘First Contract’ **when inter-alia transported to site (to be suitably modified in case of Supply-cum-supervision**



packages) by the Supplier under this ‘Second Contract’ shall give satisfactory performance in accordance with the provisions of the Contract.

Article 6. **(applicable only for package CD03)**

Integrity Pact

Under the Integrity Pact Program (IPP), a panel of Independent External Monitors (IEMs) comprising Sh. S.P. Srivastava, IPS (Retd.) & Smt. Archana Pandey Tiwari, IRS (Retd.) has been appointed by CVC. Correspondence, if any, to the panel of IEMs be addressed to the following:

Independent External Monitor

| Sl. No. | Name of IEMs | Address of IEMs |
|---------|---|--|
| 1 | Sh. S.P. Srivastava, IPS (Retd.) | 1/125, Vineet Khand, Gomtinagar, Lucknow, UP-226010 Email: sps_ips@yahoo.com |
| 2 | Smt. Archana Pandey Tiwari, IRS (Retd.) | C-32, Nangal Dewat, Vasant Kunj, New Delhi-110070 Email: ampandey2001@yahoo.com |

IN WITNESS WHEREOF the Purchaser and the Supplier have caused this Agreement to be duly executed by their duly authorized representatives the day and year first above written.

Signed by for and
on behalf of the Purchaser

.....
Signature

.....
Title

in the presence of

Signed by for and
on behalf of the Supplier

.....
Signature

.....
Title

in the presence of

Appendix-1

TERMS AND PROCEDURES OF PAYMENT

In accordance with the provisions of GCC Clause 8 (Terms of Payment), the Purchaser shall pay the Supplier in the following manner and at the following times, on the basis of the Price Breakdown given in the section on price schedules. Payments will be made in the currencies quoted by the Bidder unless otherwise agreed between the parties. The Supplier may make applications for payment in respect of part deliveries as work proceeds.

1. TERMS OF PAYMENT

All the payments to Foreign (non-resident) Suppliers will be subject to applicable Act/ Law and subject to fulfilling conditions as per GCC 5.3.

In addition to the Conditions stipulated under GCC Clause 8, the following terms & Conditions will apply.

1.1 Supply of Goods Portion

A. **Interest Bearing Advance (Optional*): Five percent (05%)** of the CIP Entry Border Point/Ex-works price component shall be paid as an interest bearing initial advance after signing the Contract Agreement and on submission of

- a) Detailed invoice,
- b) Advance Bank Guarantee for 110% (one hundred ten percent) of the amount of Advance, in line with GCC Clause 9.2,
- (c) Performance Securities in line with GCC Clause 9.3 and
- (d) Detailed PERT Network/Bar chart and its approval by the Purchaser.

Provided further that the **detailed Invoice** for advance payment along with all supporting documents is submitted by the Supplier to the Purchaser within 1 months from the date of Notification of Award. In case the Supplier does not submit the requisite documents including applicable Bank Guarantee(s)/Security(ies) within the aforesaid period, the advance shall not be payable.

Interest rate applicable on advance payment to the Supplier shall be 200 Basis Points(BPS) above the MCLR [One year Tenor rate p.a.] published by State Bank of India prevailing as on the date of drawl of advance. The said interest rate shall

remain fixed and shall be applicable till the advance amount is fully repaid. The interest will be charged considering proportionate adjustment of advance against progressive payment as per B below. The interest shall be calculated on the daily progressive balances outstanding as on the date of recovery/adjustment.

Further, the Supplier shall submit the certificate of Tax Deduction at Source (TDS) on interest within 3 months from the end of the quarter in which adjustment of advance has been made for claiming refund from Purchaser. No claim for refund will be entertained after end of the aforesaid period of 3 months. Further, while submitting the TDS Certificate the details of Contract No, Project, Region, Quarter etc to which the TDS certificate pertains, shall also be submitted tallying the amount with the TDS Certificate.

Note: * This payment is an optional payment. The Supplier has the option of taking the interest bearing initial advance or otherwise.

In case, the Supplier opts not to take interest bearing advance as above, it would be mandatory for him to submit the documents listed at Sl. No. (c) and (d) above within twenty eight (28) days of issuance of NOA.

(The above is to be incorporated in case the Supplier has opted for the interest bearing initial advance, as declared by it in its bid in the relevant Attachment to Bid Form).

B Progressive Payment

Payment of the CIP Entry Border Point /Ex-works price component (including Mandatory Spares) for each consignment shall be made progressively on certification of the Purchaser and on the basis of work performed using the following guidelines:

Eighty Five Percent (85%)** of the CIP Entry Border Point /Ex-Works price shall be paid progressively **either through irrevocable Letter of Credit (L/C) to be established in favour of the Supplier or through Direct payment** after receipt of the Goods at site and on submission of documents indicated here in under:

- (a) Evidence of receipt
 - (i) R/R or receipted L/R for goods supplied from within Nepal/India
 - (ii) Original (3/3) of the negotiable clean on-board bill of lading/Air way Bill marked freight prepaid and non-negotiable bill of lading/Air way bill for goods supplied from abroad.

- (b) Supplier's **invoice, Claim &** packing list identifying contents of each shipment.
- (c) Insurance policy/certificate
- (d) Manufacturer's/Supplier's guarantee certificate of Quality.
- (e) Material Inspection Clearance Certificate (MICC) for dispatch issued by the Purchaser's representative and the Supplier's factory inspection report.
- (f) Test certificate
- (g) Certificate of Origin
- (h) Custom clearance paper in original

** In case, the Supplier opts not to take interest bearing initial advance or has opted to take interest bearing initial advance but the advance payment has become inadmissible for the reason specified in 1.1 (A) above, then this payment shall be 90% instead of 85%.

C Final Payment

The balance 10% (Ten Percent) of the CIP Entry Border Point /Ex-Works Price Component shall be paid after Material Acceptance Certificate issued by the Purchaser's representative.

1.2 Type Test Charges

NOT APPLICABLE

1.3 Supply of Services Portion:

Port handling and custom clearance charges (in case of CIP Entry Border Point supplies) and Inland Transportation, Insurance, Loading & unloading Charges.

Port handling and custom clearance charges (in case of CIP Entry Border Point supplies) and Inland Transportation, Insurance, Loading & unloading Charges, shall be paid to the Contractor on pro-rata basis as per the unit rates indicated in the Contract Agreement, after receipt of materials/items at site, if applicable alongwith supporting documents by the Supplier. However, these charges will be subject to a limitation that the aggregate of all invoices does not exceed the total amount indicated in the Contract Agreement.

1.4 Payment towards Price adjustment:



Any variation in Contract price due to price adjustment provision of Appendix-2 shall be effected on presentation of invoice supported by calculations as per formulae specified therein along with documentary evidence for different indices applicable for Price Adjustment.

1.4.1 Any increase in Contract price due to price adjustment provision shall be payable as follows:

90% (ninety percent) of the price adjustment amount for the respective shipment shall be paid on receipt of said shipment at site. Balance 10% (ten percent) of the price adjustment amount shall be paid alongwith the final payment.

1.4.2 Any reduction in Contract Price due to price adjustment provisions shall be effected by recovering 100% of the reduction amount from Supplier's invoices falling immediately due for payment or any other payments.

2. PAYMENT PROCEDURES

2.1 Method of Payment

The Purchaser shall make payments promptly within thirty (30) days of submission of an invoice/claim by the Supplier, complete in all respects and supported by the requisite documents and fulfilment of stipulated conditions, if any. The payment due on shipment shall be paid either through irrevocable confirmed Letter of Credit to be established in favour of the Supplier or through Direct payment. The Letter of Credit shall be established in time for shipments to be made as scheduled. All other payments shall be released to the Supplier directly

All payments to be made directly to the Supplier shall be made by the Purchaser through electronic payment mechanism (e-payment) for which necessary details shall be tied up during execution of the Contract. However, a request for payment to be released through cheque shall be considered on case to case basis and merit of the same.

[The following shall be applicable in case a foreign Supplier has opted for payment in foreign currency in line with ITB Clause 12.1]

The payment of imported Equipment offered, by a Foreign Supplier, on CIF basis may be made in equivalent currency chosen by the Supplier, using the Bills Clearing (B.C.) Selling Market Rate of Exchange (MRE) established by the Bank dealing the LC, applicable on the date of release of payment(s).



All other payments excluding LC payments shall be released using the Bills Clearing (B.C.) Selling Market Rate of Exchange (MRE) established by State Bank of India (SBI), India, applicable on the date of release of payment(s).

The payments shall be made as per the following:

- (a) Initial Advance: Direct payment based on Exchange rate as indicated above applicable on the date of release of respective payment(s);
- (b) **Progressive Payment: either**
- through irrevocable confirmed Letter of Credit (LC).**

Or

through Direct payment based on Exchange rate as indicated above, applicable on the date of release of payment.

In case of payment through LC, the LC shall be opened in Nepalese Rupees. The payment shall be made to the Supplier in equivalent Foreign Currency based on Exchange rate as indicated above, applicable on the date of release of payment(s). This provision shall also be included in the conditions of LC.

Further, LC opening charges are to the account of Purchaser. If a LC is required to be extended due to non-utilisation of the same by the Supplier, the charges shall be to the Supplier's account.

- (c) **Final Payment: Direct payment based on Exchange rate as indicated above, applicable on the date of release of payment.**

All charges including wire charges towards Foreign exchange conversion for payment to foreign Supplier as indicated above shall be borne by the Supplier.

- Note: (i) Pro-rata shall refer to functionally complete part(s) of the facilities, for which unit rates are identified in the contract.
- (ii) **Before the commencement of supplies the Supplier shall inform the mode of payment (irrevocable confirmed 'Letter of Credit' or 'direct payment') through which he wants to receive the payment.**

Appendix – 2

PRICE ADJUSTMENT

1. General

1.1 Prices for work and materials covered under the scope of this Specification shall be furnished by the bidder in the manner specified in the Bid Form & Price Schedules. The bidder shall quote base prices for the CIP Entry Border Point/Ex-Works price of the goods. These price components for certain goods, as specified, shall be subject to price adjustment to reflect changes in the cost of labour and material components as per the provisions given below:

1.2 The Charges viz. Port handling and custom clearance charges (in case of CIP Entry Border Point supplies) and Inland Transportation, Insurance, Loading & unloading Charges etc. shall be firm and no price variation shall be payable for these components.

2. CIP Entry Border Point/ Ex-works Price Component

The formulae for calculating the price adjustment to be applied to the CIP Entry Border Point/ Ex-works price component of Conductor will be as follows:

$$P_1 = P_0 \times \{0.15 + a \times (A_1/A_0) + b \times (B_1/B_0) + c \times (C_1/C_0) + l \times (L_1/L_0)\} - P_0$$

Where,

P_1 = Price adjustment amount, shipment-wise (if it works out negative, that would mean the amount to be recovered by the Purchaser from the Supplier).

P_0 = CIP Entry Border Point/ Ex-works price of Conductor.

A, B & L are the indices for materials and labour as below:

A = Monthly average of “Aluminum LME SELLER Settlement Price including Premium of Al Ingots and Customs duty converted in RS./MT” as published by IEEMA/ recognized published price index for EC Grade Aluminum Ingots in India acceptable to the purchaser, in case index is not published by IEEMA (**in case of Indian bidder**)

or



Recognized published price index for EC Grade Aluminum Ingots in Nepal acceptable to the purchaser (***in case of Nepalese Bidder***)

- B = Recognized published Price Index for High Carbon Steel in the country of supplier acceptable to the Purchaser.
- C = Recognized published Price Index for High Grade Electrolytic Zinc in the country of supplier acceptable to the Purchaser.
- L = Indian field labour index – namely All India average consumer price index for Industrial Workers (monthly) (Base: 2001= 100), as published by Labour Bureau, Shimla, Government of India (www.labourbureau.nic.in).
- a = Co-efficient for EC Grade Aluminium Ingots, which shall be 0.65.
- b* = Co-efficient for High Carbon Steel, which shall be 0.13.
- c* = Co-efficient for High Grade Electrolytic Zinc, which shall be 0.02.
- l = Co-efficient for labour component, which shall be 0.05.

- (*) For bidders who intend to quote their prices based on High Tensile Galvanised Steel wire, the coefficient for the same (i.e. coefficient 'b' for High Tensile Galvanised Steel wire) shall be 0.15 and coefficient 'c' shall not be applicable. In such a case,

- B = Monthly Price exclusive of all duties of “High Tensile Galvanized Steel Wire (FE)” in Rs./MT as published by IEEMA/ recognized published Price Index for High Tensile Galvanized Steel Wire in India acceptable to the Purchaser, in case index is not published by IEEMA (***in case of Indian bidder***)

or

Recognized published price index for High Tensile Galvanized Steel Wire in Nepal acceptable to the purchaser (***in case of Nepalese Bidder***)

- 2.1 i) Subscript '0' refers to indices as on Calendar month preceding the month of opening of Bids, for materials & labour.
- ii) Subscript '1' refers to indices as applicable on Calendar month preceding the month of shipment, for materials & labour.
- 2.2 The total adjustment for Conductor shall not be subject to any ceiling whatsoever.



3. The above price adjustment provision shall be invoked by either party subject to the following further conditions:

- a) For the purpose of Price Adjustment on CIP Entry Border Point/ ex-works price components of the Goods, the month of shipment for Goods shall mean the Calendar month in which scheduled date of shipment or actual date of shipment, whichever is earlier, falls. Scheduled date of shipment will be CIP Entry Border Point/ ex-works date of despatch, governed by the accepted PERT Network/Bar Chart. However, when the Purchaser's specific approval for advancement of shipment has been obtained in such case the said advanced date shall be treated as the schedule date of shipment for the purpose of working out the price adjustment payable.

No price increase shall be allowed beyond the original delivery dates unless specifically stated in the Time Extension Letter, if any, issued by the Purchaser. The Purchaser will, however, be entitled to any decrease in the Contract Price which may be caused due to lower price adjustment amount in case of delivery of Goods beyond the original delivery dates. Therefore, in case of delivery of Goods beyond the original delivery dates, the liability of the Purchaser shall be limited to the lower of the price adjustment amount which may work out either on schedule date or actual date of despatch of Goods.

- b) In case IEEMA does not publish any of the price indices, as mentioned above, the Bidder shall indicate any nationally recognised published index for respective items and the source of the same shall be furnished in the Bid.
- c) If the Price Adjustment amount works out to be positive, the same is payable to the Supplier by the Purchaser and if it works out to be negative, the same is to be recovered by the Purchaser from the Supplier.
- d) The Supplier shall promptly submit price adjustment invoices for the supplies made, positively within three (3) months from the date of shipment, whether it is positive or negative.



Appendix-3

INSURANCE REQUIREMENTS

Insurances to be taken out by the Supplier

In accordance with the provisions of GCC Clause 28, the Supplier shall at its expense take out and maintain in effect, or cause to be taken out and maintained in effect, during the performance of the Contract, the insurances set forth below in the sums and with the deductibles and other conditions specified. The identity of the insurers and the form of the policies shall be subject to the approval of the Purchaser, such approval not to be unreasonably withheld. The inability of the insurers to provide insurance cover in the sums and with the deductibles and other conditions as set forth below, shall not absolve the Supplier of his risks and liabilities under the provisions of GCC Clause 28. However, in such a case the Supplier shall be required to furnish to the Purchaser documentary evidence from the insurer in support of the insurer's inability as aforesaid.

(a) Marine Cargo Policy/Transit Insurance Policy:

(I)(i) Marine Cargo policy for imported equipment

The Supplier shall take the Marine Cargo Policy for Goods to be supplied from abroad wherein export/import including inland transit is involved for the movement of the Goods. The policy shall cover movement of Goods from the manufacturer's works to the project's warehouse at final destination site. The policy shall cover all risk for loss or damage that may occur during transit of Goods from the Supplier's/Sub-supplier's works or stores until arrival at project's warehouse/ store at final destination. The perils required to be covered under the insurance shall include, but not be limited to, fire and allied risks, miscellaneous accidents, workman compensation risks, loss or damage in transit, theft, pilferage, riots and strikes and malicious damages, civil commotion, weather conditions, accidents of all kinds, war risks (as far as insurable) etc. Institute Cargo Clause (ICC) 'A' along with war & Strike Riots & Civil Commotion (SRCC) cover shall be taken.

(I)(ii) Transit Insurance Policy for indigenous equipment

Similarly, Transit Insurance Policy shall be taken wherein only inland transit is involved for the movement of Goods supplied from within Nepal. The policy shall cover movement of Goods from the manufacturer's works to the project's warehouse at final destination site. The perils required to be covered under

the insurance shall include, but not be limited to, fire and allied risks, miscellaneous accidents, workman compensation risks, loss or damage in transit, theft, pilferage, riots and strikes and malicious damages, civil commotion, weather conditions, accidents of all kinds, war risks (as far as insurable) etc. Inland Transit Clause (ITC) "A" alongwith Strike Riots & Civil Commotion (SRCC) extension cover shall be taken.

| Amount | Deductible Limits | Parties insured | From | To |
|--|-------------------|----------------------|-----------------|---|
| 120% of CIP Entry Border Point Price of all the Goods to be supplied from abroad plus customs duties and other applicable taxes and 120% of Ex-work Price of all the Goods to be supplied from within Nepal plus applicable taxes & duties. | Nil | Supplier & Purchaser | Mfrs ware-house | Project's ware-house store at final destination |

- (II) If during the execution of Contract, the Purchaser requests the Supplier to take any other add-on cover(s)/ supplementary cover(s) in aforesaid insurance, in such a case, the Supplier shall promptly take such add-on cover(s)/ supplementary cover(s) and the charges towards such premium for such add-on cover(s)/ supplementary cover(s) shall be reimbursed to the Supplier on submission documentary evidence of payment to the Insurance company. Therefore, charges towards premium for such add-on cover(s)/ supplementary cover(s) are not included in the Contract Price.
- (III) The Supplier shall take the policy in the joint names of Purchaser and the Supplier. The policy shall indicate the Purchaser as the beneficiary. However, if the Supplier is having an open policy for its line of business, it should obtain an endorsement of the open cover policy from the insurance company indicating that the dispatches against this Contract are duly covered under its open policy and include the name of the Purchaser as jointly Insured in the endorsements to the open policy.
- (IV) The scope of such insurance shall be adequate to cover the replacement/reinstatement cost or 120% of CIP Entry Border Point /Ex-Works cost whichever is higher, of the Goods for all risks upto and including delivery

of Goods on final destination site basis and shall also cover customs duty on merit rate, inland transportation and other costs till the Goods are delivered at site. The insurance policies to be taken should be on replacement value basis and/or incorporating escalation clause. The Purchaser shall recover the payments made except advance and the balance amount shall be released to the Supplier. Notwithstanding the extent of the insurance cover and the amount of claim available from the underwriters, the Supplier shall be liable to make good the full replacement/rectification of all Goods/Materials and to ensure their availability as per project requirements. The Supplier shall be authorized to deal directly with the insurance company.

The Purchaser shall be named as co-insured under all insurance policies taken out by the Supplier pursuant to GCC Sub-Clause 28.1. All insurer's rights of subrogation against such co-insureds for losses or claims arising out of the performance of the Contract shall be waived under such policies.

-- End --



Appendix-4

TIME SCHEDULE

1. The Delivery Schedule shall be as follows:
The delivery schedule (i.e., Receipt at Site) for the Goods and Related Services to be supplied under the subject packages shall be as follows:

| Mile Stones | Duration in days from the date of Notification of Award | Quantity to be supplied in KM | Remarks |
|-------------------------------|---|-------------------------------|--|
| 1st | 90 | 500 KM | The Bidder is required to supply the Quantity mentioned as per time Schedule. The quantities mentioned are minimum i.r.o each milestone, however, bidder may supply additional quantities i.e upto 2799 KM . |
| 2nd | 120 | 1000 KM | |
| 3rd | 180 | 1299 KM | |
| Total Quantity to be supplied | | 2799 KM | |

- 1.1 The activity(ies) under the Supplier's programme for Project Completion shall be in the form of a master network (MNW) and shall identify the various activities like design, engineering, manufacturing, supply, transportation to site and Taking Over etc. of the Goods or specific part thereof (where specific parts are specified in SCC). The network shall conform to the above Project Completion Schedule.

This master network will be discussed and agreed before Award in line with above, engineering drawing and data submission schedule shall also be discussed and finalised before Award. Liquidated damages for delay at rates specified in Clause 21 of GCC shall be applicable beyond the date specified above.

- 1.2 The Purchaser reserves the right to request minor changes in the work schedule at the time of Award of Contract to the successful Bidder.
- 1.3 The successful Bidder shall be required to prepare detailed Network(s) and project implementation plans & programmes and finalise the same with the Purchaser as per the requirement specified in Technical Specifications, which shall form a part of the Contract.
- 1.4 Time Schedule/ Delivery Schedule for completion is the essence of Contract.



Appendix-5

LIST OF APPROVED SUBCONTRACTORS

Prior to award of Contract, the following details shall be completed indicating those sub-contractors proposed by the Bidder by Attachment to its bid that are approved by the Purchaser for engagement by the Supplier during the performance of the contract.

The following Subcontractors are approved for carrying out the item of the facilities indicated. Where more than one Subcontractor is listed, the Supplier is free to choose between them, but it must notify the Purchaser of its choice in good time prior to appointing any selected Subcontractor. In accordance with GCC Sub-Clause 15.1, the Supplier is free to submit proposals for Subcontractors for additional items from time to time. No Subcontracts shall be placed with any such Subcontractors for additional items until the Subcontractors have been approved in writing by the Purchaser and their names have been added to this list of Approved Subcontractors.

| Item of Goods | Approved Subcontractors | Nationality |
|---------------|-------------------------|-------------|
| | | |
| | | |
| | | |
| | | |
| | | |
| | | |
| | | |





Appendix-6

LIST OF DOCUMENTS FOR APPROVAL OR REVIEW

Pursuant to GCC Sub-Clause 16.3.1, the Supplier shall prepare, or cause its Subcontractor to prepare, and present to the Project Manager in accordance with the requirements of GCC Sub-Clause 14.2 (Program of Performance), the following documents for:

A. Approval

- 1.
- 2.
- 3.

B. Review

- 1.
- 2.
- 3.



Note :

Bidder shall furnish the exhaustive list, which shall be discussed and finalised for incorporation into the Contract Agreement.



Appendix-7

GUARANTEES, LIQUIDATED DAMAGES FOR NON – PERFORMANCE



Not Applicable



6. PERFORMANCE SECURITY FORM

(For the purpose of verification/confirmation of this Bank Guarantee by the Purchaser, the Bank shall indicate 2 official email ids of the authorized signatories from Issuing Branch and also of the designated higher office (Corporate Office, Zonal Office etc)in the covering letter of the Bank forwarding the Bank Guarantee.)

Bank Guarantee No.

Date.....

NOA/Contract No.....

.....[Name of Contract].....

To: [Name and address of the Purchaser]

Dear Ladies and/or Gentlemen,

We refer to the Contract ("the Contract")

vide Notification of Award issued on (insert date of the notification of award)....by you to M/s (Name of Supplier),

(OR)

signed on(insert date of the Contract)..... between you and M/s (Name of Supplier),

having its Principal place of business at(Address of Supplier) and Registered Office at(Registered address of Supplier) ("the Supplier") concerning (Indicate brief scope of work) for the complete execution of the (insert name of Package alongwith name of the Project).....

By this letter we, the undersigned,(insert name & address of the issuing bank), a Bank (which expression shall include its successors, administrators, executors and assigns) organized under the laws of and having its Registered/Head Office at(insert address of registered office of the bank)..... do hereby irrevocably guarantee payment to you up to i.e., three

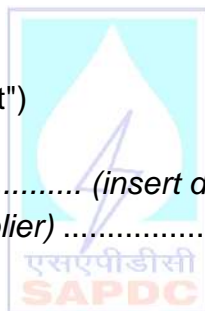



percent (3%) of the Contract Price until ninety (90) days beyond the Defect Liability Period i.e., upto and inclusive of (dd/mm/yyyy).

We undertake to make payment under this Letter of Guarantee upon receipt by us of your first written demand signed by your duly authorized officer declaring the Supplier to be in default under the Contract and without cavil or argument any sum or sums within the above named limits, without your need to prove or show grounds or reasons for your demand and without the right of the Supplier to dispute or question such demand.

Our liability under this Letter of Guarantee shall be to pay to you whichever is the lesser of the sum so requested or the amount then guaranteed hereunder in respect of any demand duly made hereunder prior to expiry of the Letter of Guarantee, without being entitled to inquire whether or not this payment is lawfully demanded.

This letter of Guarantee shall remain in full force and shall be valid from the date of issue until ninety (90) days beyond the Defect Liability Period of the Goods i.e. upto and inclusive of (dd/mm/yy) and shall be extended from time to time for such period (not exceeding one year), as may be desired by M/s. on whose behalf this Letter of Guarantee has been given.

Except for the documents herein specified, no other documents or other action shall be required, notwithstanding any applicable law or regulation.

Our liability under this Letter of Guarantee shall become null and void immediately upon its expiry, whether it is returned or not, and no claim may be made hereunder after such expiry or after the aggregate of the sums paid by us to the Purchaser shall equal the sums guaranteed hereunder, whichever is the earlier.

All notices to be given under shall be given by registered (airmail) posts to the addressee at the address herein set out or as otherwise advised by and between the parties hereto.

We hereby agree that any part of the Contract may be amended, renewed, extended, modified, compromised, released or discharged by mutual agreement between you and the Supplier, and this security may be exchanged or surrendered without in any way impairing or affecting our liabilities hereunder without notices to us and without the necessity for any additional endorsement, consent or guarantee by us, provided, however, that the sum guaranteed shall not be increased or decreased.

No action, event or condition which by any applicable law should operate to discharge us from liability hereunder shall have any effect and we hereby waive any right we may have to



apply such law so that in all respects our liability hereunder shall be irrevocable and, except as stated herein, unconditional in all respects.

“Notwithstanding anything contained herein:

1. Our liability under this Bank Guarantee shall not exceed _____ (value in figures) _____ [_____ (value in words) _____].
2. This Bank Guarantee shall be valid upto _____ (validity date) _____.
3. We are liable to pay the guaranteed amount or any part thereof under this Bank Guarantee only & only if we receive a written claim or demand on or before _____ (validity date) _____.”

For and on behalf of the Bank



[Signature of the authorised signatory(ies)]

Signature _____

Name _____

Designation _____

POA Number _____

Contact Number(s): Tel. _____ Mobile _____

Fax Number _____

email _____

Common Seal of the Bank _____

Witness:

Signature _____

Name _____

Address _____



Contact Number(s): Tel. _____ Mobile _____

email _____

Note :

1. For the purpose of executing the Bank Guarantee, the non-judicial stamp papers of appropriate value shall be purchased in the name of Bank who issues the 'Bank Guarantee'.
2. The Bank Guarantee shall be signed on all the pages by the Bank Authorities indicating their POA nos. and should invariably be witnessed.
3. The Bank Guarantee should be in accordance with the proforma as provided. However, in case the issuing bank insists for additional paragraph regarding applicability of ICC Publication No. 758, the following may be added at the end of the proforma of the Bank Guarantee [i.e., end paragraph of the Bank Guarantee preceding the signature(s) of the issuing authority(ies) of the Bank Guarantee]:

Quote

This guarantee is subjected to uniform Rules for Demand Guarantee, ICC publication No. 758 except that article 15(a) is hereby excluded.

Unquote





7. BANK GUARANTEE FORM FOR ADVANCE PAYMENT

(For the purpose of verification/confirmation of this Bank Guarantee by the Purchaser, the Bank shall indicate 2 official email ids of the authorized signatories from Issuing Branch and also of the designated higher office (Corporate Office, Zonal Office etc)in the covering letter of the Bank forwarding the Bank Guarantee.)

Bank Guarantee No.

Date.....

NOA / Contract No.....

.....[Name of Contract].....

To: [Name and address of the Purchaser]

Dear Ladies and/or Gentlemen,

We refer to the Contract ("the Contract")

vide Notification of Award issued on (insert date of the notification of award)....by you to M/s (Name of Supplier)



(OR)

signed on(insert date of the Contract)..... between you and M/s (Name of Supplier)

having its Principal place of business at(Address of Supplier) and Registered Office at(Registered address of Supplier) ("the Supplier") concerning (Indicate brief scope of work) for the complete execution of the (insert name of Package along with name of the Project).....

Whereas, in accordance with the terms of the said Contract, the Purchaser has agreed to pay or cause to be paid to the Supplier an interest bearing Advance Payment against furnishing of an irrevocable bank guarantee for an amount of(Amount



in figures and words) which is equal to 110% (one hundred ten percent) **of the amount of Advance}**

By this letter we, the undersigned,(*insert name & address of the issuing bank*), a Bank (which expression shall include its successors, administrators, executors and assigns) organized under the laws of and having its Registered/Head Office at(*insert address of registered office of the bank*)..... do hereby irrevocably guarantee repayment of(*Amount of the bank guarantee in figures and words*)..... upon the first demand of the Purchaser without cavil or argument in the event that the Supplier fails to commence or fulfill its obligations under the terms of the said Contract for reasons whatsoever.

Provided always that the Bank's obligation shall be limited to the amount of this Bank guarantee or an amount equal to the outstanding balance of the Advance Payment and the accrued interest on the Advance Payment, taking into account such amounts, which have been repaid by the Supplier from time to time in accordance with the terms of payment of the said Contract, as certified by you.

This Guarantee shall remain in full force from the date upon which the said Advance Payment is received by the Supplier up to ninety (90) days beyond the date on which the entire Advance Payment along with the accrued interest if any due thereon has been fully adjusted in terms of the Contract i.e., up to ninety (90) days beyond the completion of delivery of the Goods under the Contract. This Guarantee may be extended from time to time, as may be desired by M/s. on whose behalf this Guarantee has been issued.

Any claims to be made under this Guarantee must be received by the Bank during its period of validity, i.e. upto ninety (90) days beyond the completion of delivery of the Goods i.e. upto and inclusive of (*dd/mm/yy*).

“Notwithstanding anything contained herein:

1. Our liability under this Bank Guarantee shall not exceed _____ (*value in figures*)_____ [*value in words*]_____].
2. This Bank Guarantee shall be valid upto _____(*validity date*)_____.
3. We are liable to pay the guaranteed amount or any part thereof under this Bank Guarantee only & only if we receive a written claim or demand on or before _____ (*validity date*)_____.”



For and on behalf of the Bank

[Signature of the authorised signatory(ies)]

Signature_____

Name_____

Designation_____

POA Number_____

Contact Number(s): Tel._____ Mobile_____

Fax Number_____

email_____

Common Seal of the Bank_____

Witness:

Signature_____

Name_____

Address_____

Contact Number(s): Tel._____ Mobile_____

email_____

Note :

1. For the purpose of executing the Bank Guarantee, the non-judicial stamp papers of appropriate value shall be purchased in the name of Bank who issues the 'Bank Guarantee'.
2. The Bank Guarantee shall be signed on all the pages by the Bank Authorities indicating their POA nos. and should invariably be witnessed.
3. The Bank Guarantee should be in accordance with the proforma as provided. However, in case the issuing bank insists for additional paragraph regarding



applicability of ICC Publication No. 758, the following may be added at the end of the proforma of the Bank Guarantee [i.e., end paragraph of the Bank Guarantee preceding the signature(s) of the issuing authority(ies) of the Bank Guarantee]:

Quote

This guarantee is subjected to uniform Rules for Demand Guarantee, ICC publication No. 758 except that article 15(a) is hereby excluded.

Unquote





8. FORM OF TAKING OVER CERTIFICATE

Date.....

Name of Contract.....

Contract No.....

To :

(Name and address of the Supplier)

Dear Ladies and/or Gentlemen,

Pursuant to GCC 20.4 (Taking Over) of the General Conditions of the Contract entered into between yourselves and the Purchaser dated for (*insert Contract name*)..... we hereby notify you that the following Goods and Related Services have been used in the Facilities (*insert brief description of the facilities*) which were successfully commissioned on the date specified below, and that, in accordance with the terms of the Contract, the Purchaser hereby takes over the said Goods:

Date of Commissioning of the Facilities :

This letter is being issued to you as a confirmation of final acceptance of the Goods and does not relieve you of your obligations during the Defects Liability Period in accordance with the Contract.

Very truly yours,

Title
(Project Manager)

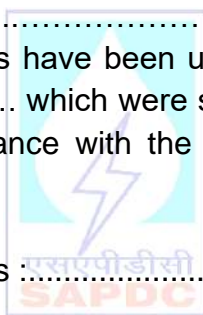



9. FORM OF EXTENSION OF BANK GUARANTEE

Ref. No.....

Dated:.....

To: *[Name and address of the Purchaser]*

Dear Sirs,

Sub.: Extension of Bank Guarantee No. dated for, issued to you on behalf of M/s. (*insert name of the Supplier*) in respect of Contract No. dated for (*insert name of the Package alongwith the Project name*) (hereinafter called original Bank Guarantee).

At the request of M/s..... (*insert name of the Supplier*), We (*insert name & address of the issuing bank*), a Bank organized under the laws of and having its Registered/Head Office at (*insert address of registered office of the bank*)..... do hereby extend our liability under the above-mentioned Guarantee No. Dated for a further period of Years/Months from to expire on Except as provided above, all other terms and conditions of the original Bank Guarantee No. dated shall remain unaltered and binding.

Please treat this as an integral part of the original Guarantee to which it would be attached.

For and on behalf of the Bank

[*Signature of the authorised signatory(ies)*]

Signature_____

Name_____

Designation_____

POA Number_____

Contact Number(s): Tel._____ Mobile_____



Fax Number _____

email _____

Common Seal of the Bank _____

Witness:

Signature _____

Name _____

Address _____

Contact Number(s): Tel. _____ Mobile _____

email _____

Note :

1. For the purpose of executing the Bank Guarantee, the non-judicial stamp papers of appropriate value shall be purchased in the name of Bank who issues the 'Bank Guarantee'.
2. The Bank Guarantee shall be signed on all the pages by the Bank Authorities indicating their POA nos. and should invariably be witnessed.

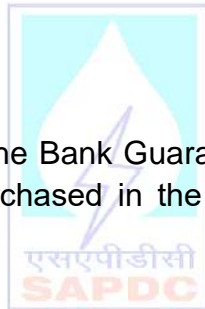



10. FORM OF POWER OF ATTORNEY FOR JOINT VENTURE (NOT APPLICABLE)

KNOW ALL MEN BY THESE PRESENTS THAT WE , the Partners whose details are given hereunder have formed a Joint Venture under the laws of and having our Registered Office(s)/Head Office(s) at (hereinafter called the 'Joint Venture' which expression shall unless repugnant to the context or meaning thereof, include its successors, administrators and assigns) acting through M/s being the Partner in-charge do hereby constitute, nominate and appoint M/s..... a Company incorporated under the laws of and having its Registered/Head Office at as our duly constituted lawful Attorney (hereinafter called "Attorney" or "Authorised Representative" or "Partner In-charge") to exercise all or any of the powers for and on behalf of the Joint Venture in regard to Specification No..... Package the bids for which have been invited by (insert name of the Purchaser alongwith address) (hereinafter called the 'Purchaser') to undertake the following acts :

- i) To submit proposal and participate in the aforesaid Bid Specification of the Purchaser on behalf of the "Joint Venture".
- ii) To negotiate with the Purchaser the terms and conditions for award of the Contract pursuant to the aforesaid Bid and to sign the Contract with the Purchaser for and on behalf of the "Joint Venture".
- iii) To do any other act or submit any document related to the above.
- iv) To receive, accept and execute the Contract for and on behalf of the "Joint Venture".

It is clearly understood that the Partner In-charge (Lead Partner) shall ensure performance of the Contract(s) and if one or more Partner fail to perform their respective portions of the Contract(s), the same shall be deemed to be a default by all the Partners.

It is expressly understood that this Power of Attorney shall remain valid binding and irrevocable till completion of the Defect Liability Period in terms of the Contract.



The Joint Venture hereby agrees and undertakes to ratify and confirm all the whatsoever the said Attorney/Authorised Representatives/Partner in-charge quotes in the bid, negotiates and signs the Contract with the Purchaser and/or proposes to act on behalf of the Joint Venture by virtue of this Power of Attorney and the same shall bind the Joint Venture as if done by itself.

IN WITNESS THEREOF the Partners Constituting the Joint Venture as aforesaid have executed these presents on this day of under the Common Seal(s) of their Companies.

for and on behalf of the
Partners of Joint Venture

.....
.....
.....

The Common Seal of the above Partners of the Joint Venture :

The Common Seal has been affixed there unto in the presence of :

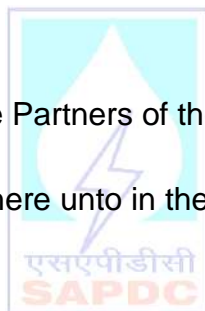

WITNESS

1. Signature.....
Name
Designation
Occupation
2. Signature.....
Name
Designation
Occupation



Note :

1. For the purpose of executing the Agreement, the non-judicial stamp papers of appropriate value shall be purchased in the name of Joint Venture.
2. The Agreement shall be signed on all the pages by the authorised representatives of each of the partners and should invariably be witnessed.





11. FORM OF UNDERTAKING BY THE JOINT VENTURE PARTNERS (NOT APPLICABLE)

THIS JOINT DEED OF UNDERTAKING executed on this..... day of..... Two Thousand and..... by a company incorporated under the laws of and having its Registered Office at(hereinafter called the "Party No.1" which expression shall include its successors, executors and permitted assigns) and M/s.....a company incorporated under the laws of and having its Registered Office at (hereinafter called the "Party No.2" which expression shall include its successors, executors and permitted assigns) and M/s.. a Company incorporated under the laws of and having its Registered Office at (hereinafter called the "Party No.3" which expression shall include its successors, executors and permitted assigns) for the purpose of making a bid and entering into a contract [hereinafter called the "Contract" {in case of award}] against the Specification No..... for (*insert name of the package alongwith project name*) of (*insert names of the Purchaser*), a Company incorporated under the Companies Act of 1956 having its registered office at(*insert registered address of the Purchaser*)..... (hereinafter called the "Purchaser").

WHEREAS the Party No.1, Party No.2 and Party No.3 have entered into an Agreement dated

AND WHEREAS the Purchaser invited bids as per the above mentioned Specification for the design, manufacture, supply and delivery of goods on final destination site basis, as stipulated in the Bidding Documents for (*insert name of the package alongwith project name*)

AND WHEREAS Clause 9.3, Section-ITB and BDS (documents establishing the Qualification of Bidder) & Qualification Criteria in Annexure-A to BDS forming part of the Bidding Documents, inter-alia stipulates that an Undertaking of two or more qualified manufacturers as partners, meeting the requirements of Qualification Criteria in Annexure-A to BDS, as applicable may bid, provided, the Joint Venture fulfills all other requirements under Clause 9.3 (c) of ITB and Qualification Criteria in Annexure-A to BDS and in such a case, the Bid Forms shall be signed by all the partners so as to legally bind all the Partners of the Joint Venture, who will be jointly and severally liable to perform the Contract and all obligations hereunder.



The above clause further states that this Undertaking shall be attached to the bid and the Contract performance guarantee will be as per the format enclosed with the Bidding Documents without any restrictions or liability for either party.

AND WHEREAS the bid is being submitted to the Purchaser vide proposal No.....dated by Party No.1 based on this Undertaking between all the parties; under these presents and the bid in accordance with the requirements of Clause 9.3, Section-ITB and BDS (documents establishing the Qualification of Bidder) & Qualification Criteria in Annexure-A to BDS, has been signed by all the parties.

NOW THIS UNDERTAKING WITNESSETH AS UNDER:

In consideration of the above premises and agreements all the parties of this Deed of Undertaking do hereby declare and undertake:

1. In requirement of the award of the Contract by the Purchaser to the Joint Venture Partners, we, the Parties do hereby undertake that M/s..... the Party No.1, shall act as Lead Partner and further declare and confirm that we the parties to the Joint Venture shall jointly and severally be bound unto the Purchaser for the successful performance of the Contract and shall be fully responsible for the design, manufacture, supply and successful performance of the goods in accordance with the Contract:
2. In case of any breach or default of the said Contract by any of the parties to the Joint Venture, the party(s) do hereby undertake to be fully responsible for the successful performance of the Contract and to carry out all the obligations and responsibilities under the Contract in accordance with the requirements of the Contract.
3. Further, if the Purchaser suffers any loss or damage on account of any breach in the Contract or any shortfall in the performance of the goods in meeting the performances guaranteed as per the specification in terms of the Contract, the Party(s) of these presents undertake to promptly make good such loss or damages caused to the Purchaser, on its demand without any demur. It shall not be necessary or obligatory for the Purchaser to proceed against Lead Partner to these presents before proceeding against or dealing with the other Party(s), the Purchaser can proceed against any of the parties who shall be jointly and severally liable for the performance and all other liabilities/obligations under the Contract to the Purchaser.
4. The financial liability of the Parties of this Deed of Undertaking to the Purchaser, with respect to any of the claims rising out of the performance or non-performance of the obligations set forth in this Deed of Undertaking, read in conjunction with the relevant



conditions of the Contract shall, however not be limited in any way so as to restrict or limit the liabilities or obligations of any of the Parties of this Deed of Undertaking.

5. It is expressly understood and agreed between the Parties to this Undertaking that the responsibilities and obligations of each of the Parties shall be as delineated in Appendix – I (*to be suitably appended by the Parties alongwith this Undertaking in its bid*) to this Deed of Undertaking. It is further undertaken by the parties that the above sharing of responsibilities and obligations shall not in any way be a limitation of joint and several responsibilities of the Parties under the Contract.
6. It is also understood that this Undertaking is provided for the purposes of undertaking joint and several liabilities of the partners to the Joint Venture for submission of the bid and performance of the Contract and that this Undertaking shall not be deemed to give rise to any additional liabilities or obligations, in any manner or any law, on any of the Parties to this Undertaking or on the Joint Venture, other than the express provisions of the Contract.
7. This Undertaking shall be construed and interpreted in accordance with the provisions of the Contract.
8. In case of an award of a Contract, we the parties to this Deed of Undertaking do hereby agree that we shall be jointly and severally responsible for furnishing a Contract performance security from a bank in favour of the Purchaser in the currency/currencies of the Contract.
9. It is further agreed that this Deed of Undertaking shall be irrevocable and shall form an integral part of the bid and shall continue to be enforceable till the Purchaser discharges the same or upon the completion of the Contract in accordance with its provisions, whichever is earlier. It shall be effective from the date first mentioned above for all purposes and intents.

IN WITNESS WHEREOF, the Parties to this Deed of Undertaking have through their authorised representatives executed these presents and affixed Common Seals of their companies, on the day, month and year first mentioned above.

Common Seal of
has been affixed in my/ our
presence pursuant to Board of
Director's Resolution dated

For Lead Partner (Party No.-1)
For and on behalf
of M/s
.....



Name

Designation

Signature

(Signature of the authorized representative)

WITNESS :

I.

II.

Common Seal of
has been affixed in my/ our
presence pursuant to Board of
Director's Resolution dated

For Party No.-2
For and on behalf of
M/s.....



Name

(Signature of the authorized representative)

Designation

Signature

WITNESS :

I.

II.

Common Seal of
has been affixed in my/ our
presence pursuant to Board of
Director's Resolution dated

For Party No.-3
For and on behalf of M/s.
.....

Name

Designation



Signature

(Signature of the authorized
representative)

WITNESS :

I.

II.

Note :

1. For the purpose of executing the Joint Deed of Undertaking, the non-judicial stamp papers of appropriate value shall be purchased in the name of Joint Venture.
2. The Undertaking shall be signed on all the pages by the authorised representatives of each of the partners and should invariably be witnessed.





12. FORMAT FOR EVIDENCE OF ACCESS TO OR AVAILABILITY OF CREDIT/FACILITIES

BANK CERTIFICATE

This is to certify that M/s. _____ (*insert Name & Address of the Supplier*) _____ who have submitted their bid to(*insert name of the Purchaser*)..... against their tender specification Vide ref. No. for (*insert name of the package alongwith the project name*) is our customer for the past years.

Their financial transaction with our Bank have been satisfactory. They enjoy the following fund based and non fund based limits including for guarantees, L/C and other credit facilities with us against which the extent of utilization as on date is also indicated below:

| Sl. No. | Type of Facility | Sanctioned Limit as on Date | Utilisation as on Date |
|---------|------------------|-----------------------------|------------------------|
| | | | |
| | | | |

This letter is issued at the request of M/s. _____.

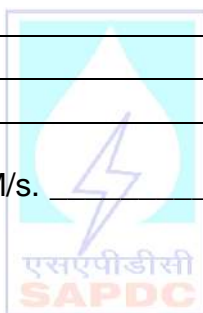

Signature _____

Name of Bank _____

Name of Authorised Signatory _____

Designation _____

Phone No. _____

Address _____

SEAL OF THE BANK



13. FORM OF MATERIAL ACCEPTANCE CERTIFICATE

Date.....

Name of Contract.....

Contract No.....

To :

(Name and address of the Supplier)

Dear Ladies and/or Gentlemen,

Pursuant to GCC 20.1 of the General Conditions of the Contract entered into between yourselves and the Purchaser dated for (*insert Contract name*)..... we hereby notify you that the delivery of following Goods has been completed at final destination site on the date specified below:

| Sl. No. | Description of Goods | Date of Delivery |
|---------|----------------------|------------------|
| | | |
| | | |
| | | |
| | | |

This letter is being issued to you as a confirmation of acceptance of the Goods by the Purchaser and the Purchaser hereby takes the responsibility for care and custody and the risk of loss thereof on the date mentioned above.

This letter does not relieve you of your other obligations including the obligations during the Defects Liability Period in accordance with the Contract.

Very truly yours,

Title
(Project Manager)



14. FORM OF JOINT DEED OF UNDERTAKING BY THE LICENSOR ALONGWITH THE BIDDER

THIS DEED OF UNDERTAKING executed this day of Two Thousand and by M/s., a Company incorporated under the laws of and having its Registered Office at (hereinafter called the “Licensor” which expression shall include its successors, executors and permitted assigns), and M/s., a Company incorporated under the laws of having its Registered Office at (hereinafter called the “Bidder”/“Supplier” which expression shall include its successors, executors and permitted assigns) in favour of **M/s. SJVN Arun-3 Power Development Company Pvt. Ltd. (SAPDC)**, a company incorporated and registered on **25.04.2013** as a private limited company under the Nepalese Companies Act 2063 duly floated by single shareholder company of **SJVN Ltd. (A CPSE under the Govt. of India)**, having its Registered offices at SAPDC, Arun-3 HEP, Satluj Bhawan, Arun Sadan, Tumlingtar, Distt. Sankhuwasabha, Nepal & SAPDC, Arun-3 HEP, 3rd Floor, Citizen Investment Trust(CIT) Building, Near to Investment Board of Nepal (IBN), New Bhaneshwor, Kathmandu (hereinafter called the “Purchaser” which expression shall include its successors, executors and permitted assigns).

WHEREAS the “Purchaser” invited Bid as per its Specification No. for design, manufacture, testing and supply of (*insert rating and name of the Goods*).....on final destination site basis for (*insert name of the package alongwith name of the project*).....

AND WHEREAS Clause No., Section, of, Vol.—... forming part of the Bid Documents inter-alia stipulates that the Bidder alongwith the Licensor must fulfill the Qualifying Requirements and be jointly and severally bound and responsible for the successful performance of the Contract in the event the Bid submitted by the Bidder is accepted by the Purchaser resulting in a Contract.

AND WHEREAS the Bidder has submitted its Bid to the Purchaser vide Proposal No. dated based on Licensee of the Licensor.

NOW THEREFORE THIS UNDERTAKING WITNESSETH as under:

1.0 In consideration of the award of Contract by the Purchaser to the Bidder (hereinafter referred to as the “Contract”) we, the Licensor and the Bidder/Supplier do hereby declare that we shall be jointly and severally bound unto the (*insert name of the Purchaser*), for the successful performance of the Contract and shall be



fully responsible for the design, manufacture, testing, supply on final destination delivery at site basis and successful performance of package(s) in accordance with the Contract Specifications.

- 2.0 Without in any way affecting the generality and total responsibility in terms of this Deed of Undertaking, the Licensor in particular hereby agrees to depute their technical experts to the Supplier's Works as considered necessary by the Purchaser, Supplier and the Licensor to ensure proper design, manufacture, Quality Management, testing, supply on final destination delivery at site basis and successful performance of the goods in accordance with Contract Specifications and if necessary the Licensor shall advise the Supplier suitable modifications of designs and implement necessary corrective measures to discharge the obligations under the Contract.
- 3.0 This Deed of Undertaking shall be construed and interpreted in accordance with the laws of Nepal and the courts in Nepal shall have exclusive jurisdiction in all matters arising under the undertaking.
- 4.0 As a security, the Licensor shall apart from the Supplier's performance guarantee, furnish a Contract Performance Guarantee from its Bank in favour of the Purchaser in a form acceptable to the Purchaser. The value of such guarantee shall be equal to **05%** of value of the Contract awarded by the Purchaser to the Supplier and it shall be part of guarantee towards the faithful performance/compliance of this Deed of Undertaking in terms of the Contract. The Guarantee shall be unconditional, irrevocable and valid for the entire period of the Contract, namely till the end of the Defect Liability Period of under the Contract. The Bank Guarantee amount shall be payable to the Purchaser on demand without any reservation or demur.
- 5.0 We, the Licensor and the Bidder/Supplier confirm that the licensee agreement shall be valid for a period of at least five (5) years after the guarantee period of the goods to be supplied under the Contract.
- 6.0 We, the Licensor and the Bidder/Supplier agree that this undertaking shall be irrevocable and shall form an integral part of the Contract and further agree that this undertaking shall continue to be enforceable till the Purchaser discharges it. It shall become operative from the effective date of Contract.

IN WITNESS WHEREOF the Licensor and the Bidder/Supplier have through their Authorised Representatives executed these presents and affixed Common seals of their respective Companies, on the day, month and year first above mentioned.



WITNESS (For Licensor)

Signature

Name

Office Address

(Signature of the authorized representative)

Name

Common Seal of Company
.....

WITNESS (For Bidder)

Signature

Name

Office Address

(Signature of the authorized representative)

Name

Common Seal of Company
.....



Note:

1. For the purpose of executing the Deed of Joint Undertaking, the non-judicial stamp papers of appropriate value shall be purchased in the name of executant(s).
2. The Undertaking shall be signed on all the pages by the authorised representatives of each of the partners and should invariably be witnessed.
3. This Deed of Joint Undertaking duly attested by Notary Public of the place(s) of the respective executant(s), shall be submitted alongwith the bid.



15. FORM OF BANK GUARANTEE FOR CONTRACT PERFORMANCE (TO BE SUBMITTED BY LICENSOR)

(For the purpose of verification/confirmation of this Bank Guarantee by the Purchaser, the Bank shall indicate 2 official email ids of the authorized signatories from Issuing Branch and also of the designated higher office (Corporate Office, Zonal Office etc)in the covering letter of the Bank forwarding the Bank Guarantee.)

Bank Guarantee No. Date.....

Contract No.....
.....[Name of Contract].....

To: [Name and address of the Purchaser]

Dear Ladies and/or Gentlemen,

We refer to the Contract ("the Contract") signed on(insert date of the Contract)..... between you and M/s (Name of Supplier), having its Principal place of business at(Address of Supplier) and Registered Office at(Registered address of Supplier) ("the Supplier") concerning (Indicate brief scope of work) for the complete execution of the (insert name of Package alongwith name of the Project).....

Whereas, M/s. (Name of Supplier), having its Principal place of business at(Address of Supplier) and Registered Office at(Registered address of Supplier) (hereinafter referred to as the "Supplier") has agreed to supply the@..... as a Licensee of M/s. (Name of Licensor), having its Principal place of business at(Address of Licensor) and Registered Office at(Registered address of Licensor) (hereinafter referred to as the "Licensor"), as a pre-requisite for qualification of the Bidder/Supplier and have submitted a deed of joint undertaking declaring that they are jointly and severally bound and responsible for the successful performance of the said goods in accordance with the Contract Specifications and that the Collaborator having agreed to furnish a Contract Performance Guarantee for the faithful performance/compliance of the Deed of Undertaking



equivalent to **(05%) five per cent** of the cost of@..... to be supplied by the Supplier under the Contract, in addition to Contract Performance Guarantee equivalent to **3% (three per cent)** of the value of the Contract to be provided by the Supplier for the faithful performance of the entire Contract.

By this letter we, the undersigned,(insert name & address of the issuing bank), a Bank (which expression shall include its successors, administrators, executors and assigns) organized under the laws of and having its Registered/Head Office at(insert address of registered office of the bank)..... do hereby irrevocably guarantee payment to you up to i.e., five percent (05%) of the cost of@..... to be supplied by the Supplier under the Contract until ninety (90) days beyond the Defect Liability Period i.e., upto and inclusive of (dd/mm/yy).

We undertake to make payment under this Letter of Guarantee upon receipt by us of your first written demand signed by your duly authorized officer declaring the Supplier to be in default under the Contract and without cavil or argument any sum or sums within the above named limits, without your need to prove or show grounds or reasons for your demand and without the right of the Supplier to dispute or question such demand.

Our liability under this Letter of Guarantee shall be to pay to you whichever is the lesser of the sum so requested or the amount then guaranteed hereunder in respect of any demand duly made hereunder prior to expiry of the Letter of Guarantee, without being entitled to inquire whether or not this payment is lawfully demanded.

This letter of Guarantee shall remain in full force and shall be valid from the date of issue until ninety (90) days beyond the Defect Liability Period of the Goods i.e. upto and inclusive of (dd/mm/yy) and shall be extended from time to time for such period (not exceeding one year), as may be desired by M/s. on whose behalf this Letter of Guarantee has been given.

Except for the documents herein specified, no other documents or other action shall be required, notwithstanding any applicable law or regulation.

Our liability under this Letter of Guarantee shall become null and void immediately upon its expiry, whether it is returned or not, and no claim may be made hereunder after such expiry or after the aggregate of the sums paid by us to you shall equal the sums guaranteed hereunder, whichever is the earlier.

All notices to be given under shall be given by registered (airmail) posts to the addressee at the address herein set out or as otherwise advised by and between the parties hereto.



We hereby agree that any part of the Contract may be amended, renewed, extended, modified, compromised, released or discharged by mutual agreement between you and the Licensor, and this security may be exchanged or surrendered without in any way impairing or affecting our liabilities hereunder without notices to us and without the necessity for any additional endorsement, consent or guarantee by us, provided, however, that the sum guaranteed shall not be increased or decreased.

No action, event or condition which by any applicable law should operate to discharge us from liability hereunder shall have any effect and we hereby waive any right we may have to apply such law so that in all respects our liability hereunder shall be irrevocable and, except as stated herein, unconditional in all respects.

“Notwithstanding anything contained herein:

1. Our liability under this Bank Guarantee shall not exceed _____ (value in figures) _____ [_____ (value in words) _____].
2. This Bank Guarantee shall be valid upto _____ (validity date) _____.
3. We are liable to pay the guaranteed amount or any part thereof under this Bank Guarantee only & only if we receive a written claim or demand on or before _____ (validity date) _____.”

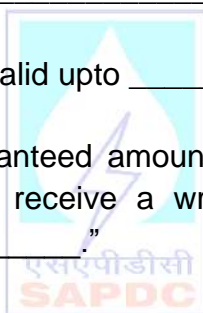

For and on behalf of the Bank

[Signature of the authorised signatory(ies)]
Signature _____

Name _____

Designation _____

POA Number _____

Contact Number(s): Tel. _____ Mobile _____

Fax Number _____

email _____



Common Seal of the Bank _____

Witness:

Signature _____

Name _____

Address _____

Contact Number(s): Tel. _____ Mobile _____

email _____

Note :

1. For the purpose of executing the Bank Guarantee, the non-judicial stamp papers of appropriate value shall be purchased in the name of Bank who issues the 'Bank Guarantee'.
2. The Bank Guarantee shall be signed on all the pages by the Bank Authorities indicating their POA nos. and should invariably be witnessed.
3. @ Insert name of the Goods
4. The Bank Guarantee should be in accordance with the proforma as provided. However, in case the issuing bank insists for additional paragraph regarding applicability of ICC Publication No. 758, the following may be added at the end of the proforma of the Bank Guarantee [*i.e., end paragraph of the Bank Guarantee preceding the signature(s) of the issuing authority(ies) of the Bank Guarantee*]:

Quote

This guarantee is subjected to uniform Rules for Demand Guarantee, ICC publication No. 758 except that article 15(a) is hereby excluded.

Unquote



16. PERFORMANCE SECURITY FORM

(TO BE SUBMITTED BY THE CONTRACTOR OPTING FOR SUBMISSION OF PERFORMANCE SECURITY WITH INITIAL VALIDITY OF 2 YEARS IN ACCORDANCE WITH CLAUSE GCC 9.3.1.1)

(For the purpose of verification/confirmation of this Bank Guarantee by the Purchaser, the Bank shall indicate 2 official email ids of the authorized signatories from Issuing Branch and also of the designated higher office (Corporate Office, Zonal Office etc)in the covering letter of the Bank forwarding the Bank Guarantee.)

Bank Guarantee No.

Date.....

NOA/Contract No.....

.....[Name of Contract].....

To: [Name and address of the Purchaser,]



Dear Ladies and/or Gentlemen,

We refer to the Contract ("the Contract")

signed on(insert date of the Contract)..... between you and M/s
(Name of Contractor),

(or)

vide notification of award issued on(insert date of the notification of award)..... by you
to M/s (Name of Contractor)

having its Principal place of business at(Address of Contractor)
..... and Registered Office at(Registered address of Contractor)
..... ("the Contractor") concerning
..... (Indicate brief scope of work) for the complete
execution of the (insert name of Package alongwith name of the Project).....



[Applicable for Bank Guarantees issued by Contractor/Associate for those Contracts awarded to them]

Or

We refer to the Contract

signed on(insert date of the Contract)..... between you and M/s
(Name of Contractor),

(or)

vide notification of award issued on(insert date of the notification of award)..... by you
to M/s (Name of Contractor)

having its Principal place of business at(Address of Contractor)
..... and Registered Office at(Registered address of Contractor)
..... ("the Contractor") and the Contract

("the Contract") signed on(insert date of the Contract)..... between you and M/s
..... (Name of Associate),

having its Principal place of business at(Address of Associate) and Registered Office at
.....(Registered address of Associate)

....., the Associate of the Contractor for
executing the Facilities concerning (Indicate brief scope of work)

..... for the complete execution of the (insert name of Package
alongwith name of the Project)..... [Applicable for Bank Guarantees to be issued by
Contractor against those Contracts awarded to their Associate]

**By this letter we, the undersigned,(insert name & address of the issuing bank)
....., a Bank (which expression shall include its successors, administrators,
executors and assigns) organized under the laws of and having
its Registered/Head Office at(insert address of registered office of the
bank)..... do hereby irrevocably guarantee payment to you up to
..... i.e., three percent (3%) of the Contract Price until 24 months
i.e., upto and inclusive of (dd/mm/yy).**

We undertake to make payment under this Letter of Guarantee upon receipt by us of your
first written demand signed by your duly authorized officer declaring the Contractor to be in
default under the Contract and without cavil or argument any sum or sums within the above
named limits, without your need to prove or show grounds or reasons for your demand and
without the right of the Contractor to dispute or question such demand.



Our liability under this Letter of Guarantee shall be to pay to you whichever is the lesser of the sum so requested or the amount then guaranteed hereunder in respect of any demand duly made hereunder prior to expiry of the Letter of Guarantee, without being entitled to inquire whether or not this payment is lawfully demanded.

This letter of Guarantee shall remain in full force and shall be valid from the date of issue until 24 months i.e. upto and inclusive of (dd/mm/yy) and shall be extended from time to time for such period, as may be desired by M/s. on whose behalf this Letter of Guarantee has been given.

Except for the documents herein specified, no other documents or other action shall be required, notwithstanding any applicable law or regulation.

Our liability under this Letter of Guarantee shall become null and void immediately upon its expiry, whether it is returned or not, and no claim may be made hereunder after such expiry or after the aggregate of the sums paid by us to you shall equal the sums guaranteed hereunder, whichever is the earlier.

All notices to be given under shall be given by registered (airmail) posts to the addressee at the address herein set out or as otherwise advised by and between the parties hereto.

We hereby agree that any part of the Contract may be amended, renewed, extended, modified, compromised, released or discharged by mutual agreement between you and the Contractor, and this security may be exchanged or surrendered without in any way impairing or affecting our liabilities hereunder without notices to us and without the necessity for any additional endorsement, consent or guarantee by us, provided, however, that the sum guaranteed shall not be increased or decreased.

No action, event or condition which by any applicable law should operate to discharge us from liability hereunder shall have any effect and we hereby waive any right we may have to apply such law so that in all respects our liability hereunder shall be irrevocable and, except as stated herein, unconditional in all respects.

Notwithstanding anything contained herein:

1. Our liability under this Bank Guarantee shall not exceed _____ (*value in figures*) _____ [*value in words*] _____.
2. This Bank Guarantee shall be valid upto _____ (*validity date*) _____.



3. We are liable to pay the guaranteed amount or any part thereof under this Bank Guarantee only & only if we receive a written claim or demand on or before _____ (validity date) _____.”

For and on behalf of the Bank

[Signature of the authorised signatory(ies)]
Signature_____

Name_____

Designation_____

POA Number_____

Contact Number(s): Tel._____ Mobile_____

Fax Number_____

email_____

Common Seal of the Bank_____

Witness:



Signature_____

Name_____

Address_____

Contact Number(s): Tel._____ Mobile_____

email_____

Note :

1. For the purpose of executing the Bank Guarantee, the non-judicial stamp papers of appropriate value shall be purchased in the name of Bank who issues the 'Bank Guarantee'.
2. The Bank Guarantee shall be signed on all the pages by the Bank Authorities indicating their POA nos. and should invariably be witnessed.



3. The Bank Guarantee should be in accordance with the proforma as provided. However, in case the issuing bank insists for additional paragraph regarding applicability of ICC publication No: 758, the following may be added at the end of the proforma of the Bank Guarantee [*i.e., end paragraph of the Bank Guarantee preceding the signature(s) of the issuing authority(ies) of the Bank Guarantee*]:
“This Guarantee is subject to Uniform Rules for Demand Guarantee, ICC publication No. 758 except that article 15(a) is hereby excluded.”

----- End of Section-VI (FP) -----



VOLUME-II

TECHNICAL SPECIFICATION

STANDARD TECHNICAL SPECIFICATION

FOR

**CONDUCTOR PACKAGE CD03 for 400KV D/C
(Quad Moose) Diding – Dhalkebar –Bathnaha
TL (Tower Package TW02)**

FOR

**TRANSMISSION SYSTEM ASSOCIATED WITH
ARUN-3 HEP IN NEPAL**

| CONTENT | |
|--|---|
| Volume-II : Technical Specification | |
| Section-I | GENERAL INFORMATION AND SCOPE |
| Section-II | TECHNICAL SPECIFICATION FOR ACSR CONDUCTOR |
| Section-III | MANUFACTURING QUALITY PLAN |



Volume-II : Technical Specification
SECTION-I
GENERAL INFORMATION AND SCOPE

CONTENTS

| Clause No. | Description |
|-------------------|--------------------------------|
| 1.0 | General Information |
| 2.0 | Scope |
| 3.0 | Weights and Measures |
| 4.0 | General Technical Conditions |
| 5.0 | Technical Description |
| 6.0 | Test and Standards |
| 7.0 | Standard Technical Particulars |
| 8.0 | Technical Information |
| 9.0 | Details of line Material |
| 10.0 | Service Condition |





TECHNICAL SPECIFICATIONS SECTION-I

1.0 General Information

1.1 The conductor covered in this specification shall be used in transmission lines for Transmission System associated with Arun-3 HEP in NEPAL:

| Package | Transmission Line | Tentative Route Length (kms) | Conductor Type/ Name | Bundle Configuration |
|---------|--|------------------------------|----------------------|----------------------|
| CD03 | 400KV D/C (QuadMoose) Diding – Dhalkebar – Bathnaha TL. | 124KM | ACSR Moose | Quad |

2.0 Scope

2.1 The conductor to be supplied on final destination at site basis, as covered in this volume, shall be designed, manufactured and tested as per the requirements specified. Final destination shall mean the stores established by the contractor of the purchaser along the transmission lines.

The details of the conductor required under this specification are mentioned in the bidding documents.

3.0 Weights and Measures

All weights and measures shall be in System International (S.I.) units.

4.0 General Technical Conditions

4.1 The following provisions shall supplement all the detailed technical specifications and requirements brought out in the accompanying Technical Specifications. The bidder's proposal shall be based on the use of equipment and materials complying fully with the requirements, specified herein.

4.2 Equipment Performance Guarantee

4.2.1 The performance requirements of conductor are detailed separately in this



specification. These guarantees shall supplement the general performance guarantee provisions covered under General Terms and Conditions of Contract in clause entitled 'Guarantee'.

- 4.2.2 Liquidated damages for not meeting specified performance shall be assessed and recovered from the supplier. Such liquidated damages shall be without any limitation whatsoever and shall be in addition to damages, if any payable under any other clause of Conditions of Contract.

4.3 Drawings

- 4.3.1 The standard drawing of the drum for conductor is enclosed with the Section-II of this specification. The Bidder shall supply the conductor in the drum conforming to the specification drawing and details given in the Section-II of this volume.

4.4 Manufacturing Schedule

The supplier shall submit to the purchaser the manufacturing, testing and delivery schedules of conductor within thirty (30) days from the date of the Letter of Award in accordance with the delivery requirements stipulated. Schedules shall also include the materials and items purchased from outside suppliers, if any.

4.5 Reference Standards

- 4.5.1 The Codes and/or Standards referred to in specifications shall govern, in all cases wherever such references are made. In case of a conflict between such Codes and/or Standards and the specifications, latter shall govern. Such Codes and/or Standards, referred to shall mean the latest revisions, amendments/changes adopted and published by the relevant agencies.
- 4.5.2 Other internationally acceptable standards which ensure equivalent or better performance than those specified shall also be accepted.

4.6 Design Improvements

- 4.6.1 The purchaser or the supplier may propose changes in the specification of the conductor or quality thereof and if the parties agree upon any such changes, the specification shall be modified accordingly.
- 4.6.2 If any such agreed upon change is such that it affects the price and

schedule of completion, the parties shall agree in writing as to the extent of any change in the price and/or schedule of completion before the supplier proceeds with the change. Following such agreement, the provision thereof, shall be deemed to have been amended accordingly.

4.7 Quality Assurance

- 4.7.1 To ensure that the conductor under the scope of this Contract whether manufactured within the supplier's works or at his sub-supplier's premises is in accordance with the specifications, the supplier shall adopt Standard Quality Assurance Plan to control such activities at all points necessary.
- 4.7.2 The Standard Manufacturing Quality Plan (SMQP) document is enclosed at section-III of this volume.
- 4.7.3 The purchaser or his duly authorised representatives reserves the right to carry out Quality Audit and quality surveillance of the systems and procedures of the supplier's/his vendor's Quality Management and Control Activities.

4.8 Purchaser's Responsibility

- 4.8.1 The scope of the duties of the purchaser, pursuant to the contract, will include but not be limited to the following :
- (a) Interpretation of all the terms and conditions of these documents and specifications.
 - (b) Review and interpretation of all the drawings, engineering data, etc.
 - (c) Witness or authorise his representative to witness tests at the manufacturer's works or at site, or at any place where work is performed under the Contract.
 - (d) Inspect, accept or reject any equipment, material and work under the Contract, in accordance with the specifications.
 - (e) Issue certificate of acceptance and/or progressive payment and final payment certificate.
 - (f) Review and suggest modification and improvement in completion schedules from time to time, and
 - (g) Supervise the Quality Assurance Programme implementation at all



stages of the works.

4.9 Inspection, Testing & Inspection Certificate

- 4.9.1 The purchaser, his duly authorised representative and/or outside inspection agency acting on behalf of the purchaser shall have at all reasonable times access to the supplier's premises and works and shall have the power at all reasonable times to inspect and examine the materials and workmanship of the product during its manufacture. If part of the product is being manufactured or assembled at other premises or works, the supplier shall obtain for the purchaser and/or his duly authorised representative permission to inspect as if the equipment/ materials were manufactured or assembled on the supplier's own premises or works.
- 4.9.2 The supplier shall give the purchaser/ inspector fifteen (15) days written notice of any material being ready for testing. Such tests shall be to the supplier's account except for the expenses of the inspector. The purchaser/inspector, unless witnessing of the tests is waived, will attend such tests within fifteen (15) days of the date of which the equipment is notified as being ready for test/inspection or on a mutually agreed date, failing which the supplier may proceed with the test which shall be deemed to have been made in the inspector's presence and he shall forthwith forward to the inspector duly certified copies of tests in triplicate.
- 4.9.3 The purchaser/inspector shall, within fifteen (15) days from the date of inspection as defined herein give notice in writing to the supplier, of any objection to any drawings and all or any equipment and workmanship which in his opinion is not in accordance with the Contract. The supplier shall give due consideration to such objections and shall make the modifications that may be necessary to meet the said objections.
- 4.9.4 When the factory tests have been completed at the supplier's or sub-supplier's works, the purchaser/ inspector shall issue a certificate to this effect within fifteen (15) days after completion of tests but if the tests are not witnessed by the purchaser/inspector, the certificate shall be issued within fifteen (15) days of receipt of the supplier's Test Certificate by the purchaser/ inspector. The completion of these tests or the issue of the certificate shall not bind the purchaser to accept the equipment should it, on further tests after erection, be found not to comply with the Contract.
- 4.9.5 In all cases where the Contract provides for test whether at the premises or works of, the supplier or of any sub-supplier, the supplier except where otherwise specified shall provide free of charge such item as labour, materials, electricity, fuel, water, stores, apparatus and instruments as may

be reasonably demanded by the purchaser/inspector or his authorised representative to carry out effectively such tests of the equipment in accordance with the Contract and shall give facilities to the purchaser/inspector or to his authorised representative to accomplish testing.

- 4.9.6 The inspection by purchaser and issue of Inspection Certificate thereon shall in no way limit the liabilities and responsibilities of the supplier in respect of the Standard Quality Assurance Programme forming part of the Contract.

5.0 Technical Description

- 5.1 The technical description of Conductor shall be as specified in Section-II of this Technical Specifications.

6.0 Tests and Standards

6.1 Tests

The following type, acceptance and routine tests and tests during manufacture shall be carried out on the conductor. For the purpose of this clause:

- 6.1.1 Type Tests shall mean those tests which are to be carried out to prove the process of manufacture and general conformity of the material to this Specification The Bidder shall indicate his schedule for carrying out these tests, if required.
- 6.1.2 Acceptance Tests shall mean those tests which are to be carried out on samples taken from each lot offered for pre-dispatch inspection, for the purpose of acceptance of that lot.
- 6.1.3 Routine Tests shall mean those tests, which are to be carried out on the material by the manufacturer to check requirements which are likely to vary during production.
- 6.1.4 Tests during manufacture shall mean those tests, which are to be carried out during the process of manufacture and end inspection by the supplier to ensure the desired quality of the end product to be supplied by him.
- 6.1.5 The norms and procedure of sampling for these tests will be as per the Standard Quality Assurance Programme.
- 6.1.6 The standards and norms to which these tests will be carried out are listed against them. Where a particular test is a specific requirement of this Specification, the norms and procedure of the test shall be as specified in

Annexure-B or Standard Quality Assurance Programme.

6.1.7 For all type and acceptance tests, the acceptance values shall be the values specified in this Specification.

7.0 Standard Technical Particulars

7.1 The Standard Technical Particulars of the conductor which the bidder has to guarantee are specified in Section-II of this volume. The Bidder shall furnish any other information as in their opinion is needed to give full description and details to judge the item(s) offered by them

8.0 Technical Information

765 kV transmission line

| | | | |
|----|---|--------------------------|------|
| | Nominal Voltage | kV | 765 |
| 2. | Maximum system voltage | kV | 800 |
| 3. | BIL (Impulse) | kV (Peak) | 2400 |
| 4. | Power frequency withstand voltage (Wet) | kV (rms) | 830 |
| 5. | Switching surge withstand voltage (Wet) | kV (peak) | 1550 |
| 6. | Minimum Corona extinction voltage at 50 Hz AC system under dry condition | kV (rms) phase to earth. | 510 |
| 7. | Maximum Radio interference voltage at one MHz for phase to earth voltage of 510 kV under dry condition. | Micro Volts | 1000 |

400 kV transmission line

| | | | |
|----|--|--------------------------|------|
| 1. | Nominal Voltage | kV | 400 |
| 2. | Maximum system voltage | kV | 420 |
| 3. | BIL (Impulse) | kV (Peak) | 1550 |
| 4. | Power frequency withstand voltage (Wet) | kV (rms) | 680 |
| 5. | Switching surge withstand voltage (Wet) | kV (peak) | 1050 |
| 6. | Minimum Corona extinction voltage at 50 Hz AC system under dry condition | kV (rms) phase to earth. | 320 |



| | | | |
|----|---|-------------|------|
| 7. | Maximum Radio interference voltage at one MHz for phase to earth voltage of 305 KV under dry condition. | Micro Volts | 1000 |
|----|---|-------------|------|

220 kV transmission line

| | | | |
|----|---|--------------------------|------|
| 1. | Nominal Voltage | kV | 220 |
| 2. | Maximum system voltage | kV | 245 |
| 3. | BIL (Impulse) | kV (Peak) | 1050 |
| 4. | Power frequency withstand voltage (Wet) | kV (rms) | 460 |
| 5. | Minimum Corona extinction voltage at 50 Hz AC system under dry condition | kV (rms) phase to earth. | 154 |
| 6. | Maximum Radio interference voltage at one MHz for phase to earth voltage of 154 KV under dry condition. | Micro Volts | 1000 |

132 kV transmission line

| | | | |
|----|---|-----------|-----|
| 1. | Nominal Voltage | kV | 132 |
| 2. | Maximum system voltage | kV | 145 |
| 3. | BIL (Impulse) | kV (Peak) | 650 |
| 4. | Power frequency withstand voltage (Wet) | kV (rms) | 275 |

±500 kV HVDC transmission line

| | | | |
|----|--|-------------|------|
| 1. | Nominal Voltage | kV | 500 |
| 2. | Maximum system voltage | kV | 525 |
| 3. | BIL (Impulse) | kV (Peak) | 1800 |
| 4. | Switching surge withstand voltage (Wet) | kV (Peak) | 1000 |
| 5. | Minimum Corona extinction voltage under dry condition | kV | 550 |
| 6. | Maximum Radio interference voltage at one MHz for conductor surface gradient of 22 kV/cm (positive) under dry condition. | Micro Volts | 1000 |

±800 kV HVDC transmission line

| | | | |
|----|--|-------------|------|
| 1. | Nominal Voltage | kV | 800 |
| 2. | Maximum system voltage | kV | 840 |
| 3. | BIL (Impulse) | kV (Peak) | 2250 |
| 4. | Switching surge withstand voltage (Wet) | kV (Peak) | 1850 |
| 5. | Minimum Corona extinction voltage under dry condition | kV | 880 |
| 6. | Maximum Radio interference voltage at one MHz for conductor surface gradient of 22 kV/cm (positive) under dry condition. | Micro Volts | 1000 |

9.0 Service Condition

Conductor to be supplied against this specification shall be suitable for satisfactory continuous operation under conditions as specified below:

| | |
|--|--|
| Maximum ambient temperature (°C) | 45 |
| Minimum ambient temperature (°C) | 0 |
| Relative humidity (% range) | 10-100 |
| Maximum annual rainfall & snowfall (Cm) | as per published Meteorological/ climatological data |
| Wind zone (as per IS: 875) | 4 |
| Maximum wind velocity (m/sec.) | 47 |
| Maximum altitude above mean sea level(m) | Upto 2000 |
| Isokeraunic level (days/years) | 60 |

Climate varies from moderately hot and humid tropical climate to cold climate.

Volume-II : Technical Specification
SECTION-II
TECHNICAL SPECIFICATIONS

CONTENTS

| Clause No. | Description |
|-------------------|---|
| 1.0 | Technical Description of ACSR Conductor |
| 2.0 | Tests and Standards |
| | Annexure-A : Standard Technical Particulars |
| | Annexure-B : Tests on Conductor |
| | Annexure-C : Drum Drawings |



TECHNICAL SPECIFICATIONS

SECTION-II

1. Technical Description of ACSR Conductor

1.1 Details of Conductor

1.1.1 The ACSR Conductor shall generally conform to IEC: 61089/ IS: 398 (relevant part)/ ASTM:B-232 except where otherwise specified herein.

1.1.2 Standard Technical Particulars

The Standard Technical Particulars (STP) of the ACSR conductors are enclosed at Annexure-A of this section. The values indicated in the STP are the minimum and/or maximum values required to be met by the supplier.

1.2 Workmanship

1.2.1 All the aluminium and steel strands shall be smooth, uniform and free from all imperfections, such as spills and splits, die marks, scratches, abrasions, etc., after drawing and also after stranding.

1.2.2 The finished conductor shall be smooth, compact, uniform and free from all imperfections including kinks (protrusion of wires), wire cross over, over riding, looseness (wire being dislocated by finger/hand pressure and/or unusual bangle noise on tapping), material inclusions, white rust, powder formation or black spot (on account of reaction with trapped rain water etc.), dirt, grit etc.

1.2.3 The steel strands shall be hot dip galvanised and shall have a minimum zinc coating as indicated in the STP. The zinc coating shall be smooth, continuous, of uniform thickness, free from imperfections and shall withstand number of dips in Standard Preece test as indicated in STP. The steel wire rods shall be of such quality and purity that, when drawn to the size of the strands specified and coated with zinc, the finished strands and the individual wires shall be of uniform quality and have the same properties and characteristics as prescribed in IEC: 60888.

1.2.4 The steel strands shall be preformed and post formed in order to prevent spreading of strands in the event of cutting of complete core. Care shall be taken to avoid, damages to galvanisation during pre-forming and post-forming operation.

1.3 Joints in Wires

1.3.1.1 Aluminium Wires

1.3.1.2 During stranding, no aluminium wire welds shall be made for the purpose

of achieving the required conductor length.

1.3.1.3 No joints shall be permitted in the individual wires in the outer most layer of the finished conductor. However joints are permitted in the inner layer of the conductor unavoidably broken during stranding provided such breaks are not associated with either inherently defective wire or with the use of short lengths of aluminium wires. Such joints shall not be more than four (4) per conductor length and shall not be closer than 15 meters from joint in the same wire or in any other aluminium wire of the completed conductor.

1.3.1.4 Joints shall be made by cold pressure butt welding and shall withstand a stress of not less than the breaking strength of individual strand as per STP.

1.3.2 Steel Wires

There shall be no joint of any kind in the finished wire entering into the manufacture of the strand. There shall also be no strand joints or strand splices in any length of the completed stranded steel core of the conductor.

1.4 Tolerances

The manufacturing tolerances to the extent indicated in the STP shall be permitted in the diameter of individual aluminium and steel strands and lay-ratio of the conductor.

1.5 Materials

1.5.1 Aluminium

The aluminium strands shall be hard drawn from electrolytic aluminium rods having purity and copper content as per the values indicated in the STP. They shall have the same properties and characteristics as prescribed in IEC: 60889.

1.5.2 Steel

The steel wire strands shall be drawn from high carbon steel wire rods produced by either the acid or the basic open-hearth process, the electric furnace process, or the basic oxygen process and shall conform to the chemical composition indicated in the STP.

The Steel wire strands shall have the same properties and characteristics as prescribed for regular strength steel wire in IEC : 60888.

1.5.3 Zinc

The zinc used for galvanizing shall be electrolytic High Grade Zinc of purity as indicated in the STP. It shall conform to and satisfy all the requirements of IS:209.



1.6 Standard Length

- 1.6.1 The standard length of the conductor shall be as indicated in the STP. All lengths outside this limit of tolerance shall be treated as random lengths. Not less than 90% of the total quantity of the conductor shall be supplied in standard lengths.
- 1.6.2 Random lengths will be accepted provided no length is less than 70% of the standard length and the total quantity of such random lengths shall not be more than 10% of the total quantity ordered. At any point, the cumulative quantity supplied of such random lengths shall not be more than 12.5% of the total cumulative quantity supplied including such random lengths. However, the last 20% of the quantity ordered shall be supplied only in standard lengths as specified.
- 1.6.3 The purchaser reserves the right to place orders for the lengths above the standard length on the same terms and conditions applicable for the standard lengths during the pendency of the Contract.

2.0 Tests and Standards

2.1 Type Tests

The following tests shall be conducted on a sample/samples of the conductor(s) required under the package from each stranding machine from which the conductor is to be manufactured & supplied:

- a) DC resistance test on stranded conductor
- b) UTS test on stranded conductor
- c) Corona extinction voltage test (dry) *
- d) Radio interference voltage test (dry) *

As per Annexure-B

* applicable for 220 kV or above voltage level only

- 2.1.1 Type tests specified under Clause 2.1 shall not be required to be carried out if supplier has conducted these tests earlier on the same conductor & same bundle configuration (applicable for tests 'c' & 'd') and valid type test certificates are available. The test certificate shall be considered valid if,
- i) Tests conducted earlier is either conducted in accredited laboratory (accredited based on ISO/IEC vide 25/17025 or EN 45001 by the National accreditation body of the country where laboratory is located) or witnessed by the representative(s) of SAPDC or utility and
 - ii) Tests conducted on the samples of conductor manufactured from same stranding machine within 3 (three) years prior to the date of



commencement of manufacturing for the package. However, the manufacturing of the conductor for the package can be carried till 3 (three) years from the date of type testing.

In case the tests have been conducted earlier than the above stipulated period or carried out on another stranding machine or in the event of any discrepancy in the test report (i.e., any test not applicable due to any design/manufacturing change including substitution of components or due to non-compliance with the requirement stipulated in the Technical Specifications), the tests shall be conducted by the supplier at no extra cost to the purchaser. Also, in case, manufacturing (scheduled/actual) is beyond the 3 (three) years from the date of type testing, supplier has to repeat the above type tests at no extra cost to the purchaser.

2.2 Acceptance Tests

- | | |
|---|---------------------|
| a) Visual and dimensional check on drum | |
| b) Visual check for joints, scratches etc. and length measurement of conductor by rewinding | |
| c) Measurement of diameters of individual Steel and Aluminium strands | As per Annexure-B |
| d) Check for lay-ratios of various layers | |
| e) Galvanizing test on steel strands | |
| f) Torsion and Elongation tests on steel strands | |
| g) Breaking load test on steel and Aluminium strands | IEC : 60888 & 60889 |
| h) Wrap test on Steel & Aluminium strands | IEC : 60888 & 60889 |
| i) DC resistance test on Aluminium strands | IEC : 60889 |
| j) Procedure qualification test on welded joint of Aluminium strands | As per Annexure-B |
| k) Drum strength test (steel drum) | As per Annexure-B |
| l) Barrel Batten strength test (wooden drum) | As per Annexure-B |

Note: All the above tests except (j) shall be carried out on Aluminium and steel strands after stranding only.

- 2.2.1 The above acceptance tests shall be repeated on one conductor sample taken from site in presence of Owner's representative for each 500km progressive supply. The tests shall be carried out by the supplier at his



cost at its own premises or any other tests centre having required facilities. The sample shall be selected by Owner's site representative and the tests shall be witnessed by Owner's QA&I representative. In case of evidence of non-compliance, it shall be binding on the part of the supplier to prove compliance of the items to the technical specification by repeat tests, or correction of deficiencies, or replacement of defective items all, without any extra cost to the purchaser.

2.3 Routine Test

- a) Check to ensure that the joints are as per Specification
- b) Check that there are no cuts, fins etc. on the strands
- c) Check that drums are as per Specification
- d) All acceptance test as mentioned above to be carried out on aluminium and steel strands of 20% of drums

2.4 Tests During Manufacture

- | | |
|---|----------------------|
| <ol style="list-style-type: none"> a) Chemical analysis of zinc used for galvanizing b) Chemical analysis of Aluminium used for making Aluminium strands c) Chemical analysis of steel used for making steel strands | As per Annexure-B |
|---|----------------------|

2.5 Testing Expenses

- 2.5.1 In the event of type testing, bidder shall ensure that adequate facilities are available in the laboratories and the tests can be completed in these laboratories within the time schedule.
- 2.5.3 In case of failure in any type test, the supplier is either required to manufacture fresh sample lot and repeat the entire tests successfully once or repeat that particular type test three times successfully on the sample selected from the already manufactured lot at his own expense. In case a fresh lot is manufactured for testing then the lot already manufactured shall be rejected.
- 2.5.4 The entire cost of testing for the type, acceptance, routine tests and tests during manufacture specified herein shall be treated as included in the quoted unit price of conductor, except for the expenses of the inspector/purchaser's representative.
- 2.5.5 In case of failure in any type test, if repeat type tests are required to be

conducted, then all the expenses for deputation of inspector/purchaser's representative shall be to the supplier's account. Also, if on receipt of the supplier's notice of testing, the purchaser's representative does not find the test samples or testing facilities/equipments ready for testing, the expenses incurred by the purchaser for re-deputation shall be to the supplier's account.

2.6 Additional Tests

- 2.6.1 The purchaser reserves the right of having at his own expenses any other test(s) of reasonable nature carried out at supplier's premises, at site or in any other place in addition to the aforesaid type, acceptance and routine tests to satisfy himself that the materials comply with the Specifications.
- 2.6.2 The purchaser also reserves the right to conduct all the tests mentioned in this specification at his own expense on the samples drawn from the site at supplier's premises or at any other test centre. In case of evidence of non compliance, it shall be binding on the part of supplier to prove the compliance of the items to the technical specifications by repeat tests, or correction of deficiencies, or replacement of defective items all without any extra cost to the purchaser.

2.7 Sample Batch For Type Testing

- 2.7.1 In case the type tests are required to be carried out, the samples for type testing shall be manufactured in accordance with the Standard Manufacturing Quality Plan.
- 2.7.2 The supplier shall offer at least three drums for selection of sample required for conducting all the type tests.
- 2.7.3 The supplier is required to carry out all the acceptance tests successfully in presence of purchaser's representative before sample selection.

2.8 Test Reports

- 2.8.1 In case type tests have been carried out earlier by the supplier and valid type test reports are available as specified in clause 2.1.1 above, the supplier shall submit one copy of the test report along with approval letter issued by SAPDC or utility.
- 2.8.2 In case fresh type tests have been carried out under the package, the type test reports shall be furnished in original along with two copies. One copy will be returned duly certified by the purchaser.
- 2.8.2 The commercial production of the conductor can be taken up by the supplier after clearance from the purchaser.
- 2.8.3 Record of routine test reports shall be maintained by the supplier at his works for periodic inspection by the purchaser's representative.

2.8.4 Test Certificates of tests during manufacture shall be maintained by the supplier. These shall be produced for verification as and when desired by the purchaser.

2.9 Inspection

2.9.1 The purchaser's representative shall at all times be entitled to have access to the works and all places of manufacture, where conductor shall be manufactured and representative shall have full facilities for unrestricted inspection of the supplier's works, raw materials and process of manufacture for conducting necessary tests as detailed herein.

2.9.2 The supplier shall keep the purchaser informed in advance of the time of starting and of the progress of manufacture of conductor in its various stages so that arrangements can be made for inspection.

2.9.3 No material shall be dispatched from its point of manufacture before it has been satisfactorily inspected and tested, unless the inspection is waived off by the purchaser in writing. In the latter case also the conductor shall be dispatched only after satisfactory testing for all tests specified herein have been completed.

2.9.4 The acceptance of any quantity of material shall in no way absolve the supplier of any of his responsibilities for meeting all requirements of the Specification, and shall not prevent subsequent rejection if such material is later found to be defective.

2.10 Test Facilities

2.10.1 The following test facilities shall be available at the supplier's works:

- a) Various testing and measuring equipment for carrying out specified acceptance tests, routine tests and tests during manufacture inter alia including tensile testing machine, resistance measurement facilities, torsion & wrap testing machine, dimension checking instruments viz. digital vernier and micrometer etc., galvanizing test instruments viz. digital elcometer and standard preece test etc., burette, digital thermometer, barometer etc.
- b) Digital milli/micro ohm meter along with standard resistance for calibration of resistance bridges.
- c) Spectrometer, if supplier has its own properzi mill
- c) Finished conductor shall be checked for length verification and surface finish on separate rewinding machine at reduced speed (variable from 8 to 16 meters per minute). The rewinding facilities shall have appropriate clutch system and free of vibrations, jerks etc. with traverse laying facilities.

2.11 Packing

- 2.11.1 The conductor shall be supplied in returnable, painted steel drums of adequate strength, constructed to protect the conductor against all damage and displacement during transit, storage and subsequent handling and stringing operations in the field. The supplier shall be responsible for any loss or damage during transportation, handling and storage due to improper packing.
- 2.11.2 One standard length shall be wound on each drum. The drums shall be suitable for wheel mounting and for letting off the conductor under a minimum controlled tension of the order of 5 KN.
- 2.11.3 The standard drawing of the drum for conductor is enclosed with the specification. The Bidder shall supply the conductor in the drum conforming to the specification drawing. After preparation of steel surface according to IS:9954, synthetic enamel paint shall be applied after application of one coat of primer.
- 2.11.4 The ownership of the empty conductor drums shall lie with the conductor supplier who shall ultimately take back the empty conductor drums from the erection contractor's designated stores at project site(s) after the running out of conductor from the drums.
- 2.11.5 The erection contractor shall intimate the conductor supplier and employer regarding empty steel drums at their designated stores. Necessary coordination for taking back the empty steel drums in this regard shall be done by the conductor supplier with the erection contractor.
- 2.11.6 The empty drums shall be taken back by the conductor supplier from the stores of erection contractor as & when these are available after usage of conductor. Conductor supplier shall be required to take back the empty steel drum within a period of one month from date of information by erection contractor regarding availability of the drums at erection contractor stores. However, 2% of the total drums shall not be returned to the conductor supplier as these may be used for storage of spare conductor by the purchaser.
- 2.11.7 The steel drums may get damaged and/or wear & tear during transportation, normal handling & operation at site, which shall be rectified by the conductor supplier before re-use. However, 2% of the total drums shall not be returned on account of damages / wastage for which no compensation will be payable. The wastage beyond 2% shall be reimbursed by erection contractor.
- Thus, 4% of total drums shall not be returnable to the conductor supplier.
- 2.11.8 Solid Polypropylene sheet of minimum 5mm thickness shall be used for

outer covering of conductor. Outside the covering, there shall be minimum two binders consisting of hoop iron/galvanised steel wire. Two numbers of additional binders per drum shall also be supplied for re-wrapping the polypropylene sheet with each lot of conductor and 5 nos. crimping machines with the first lot of conductor for crimping the binders at site. As an alternative, supplier may use wooden lagging of minimum 50 mm thickness for outer covering of conductor without any extra financial implication to the purchaser.

- 2.11.9 As an alternative to returnable steel drum, bidder may supply the conductor in non-returnable wooden drums. However, for bid evaluation purpose, both types of drums shall be treated at par and bidder may quote accordingly.
- 2.11.10 The standard drawing of the wooden drum for conductor is also enclosed with the specification. The Bidder shall supply the conductor in the drum conforming to the specification drawing.
- 2.11.11 The wooden drums shall generally conform to IS:1778, except as otherwise specified hereinafter. All wooden components shall be manufactured out of seasoned soft wood, free from defects that may materially weaken the component parts of the drums. Preservative treatment shall be applied to the entire drum with preservatives of a quality which is not harmful to the conductor.
- 2.11.12 Before reeling, card board or double corrugated or thick bituminised water-proof bamboo paper shall be secured to the drum barrel and inside of flanges of the drum by means of a suitable commercial adhesive material over which HDPE sheet to be provided. After reeling the conductor, the exposed surface of the outer layer of conductor shall be wrapped with self-adhesive plastic sheet to preserve the conductor from ingress of water, dirt, grit and damages during storage, transport and handling.
- 2.11.13 The conductor ends shall be properly sealed and secured on the side of one of the flanges to avoid loosening of the conductor layers during transit and handling.

2.12 Marking

Each drum shall have the following information stenciled on it in indelible ink along with other essential data :

- (a) Contract/Award letter number.
- (b) Name and address of consignee.
- (c) Manufacturer's name and address.
- (d) Drum number
- (e) Size of conductor
- (f) Length of conductor in meters
- (g) Arrow marking for unwinding
- (h) Position of the conductor ends

- (i) Barrel diameter at three locations & an arrow marking at the location of the measurement.
- (j) Number of turns in the outer most layer.
- (k) Gross weight of drum after putting lagging.
- (l) Tear weight of the drum without lagging.
- (m) Net weight of the conductor in the drum.
- (n) CIP/MICC No.

The above should be indicated in the packing list also.

2.13 Verification of Conductor Length

The purchaser reserves the right to verify the length of conductor after unreeling. The quantity for verification shall be between a minimum of five percent (5%) to a maximum of ten percent (10%) in a lot offered for inspection. The actual quantity will be discussed and mutually agreed to by the supplier & purchaser.

2.14 Standards

- 2.14.1 The conductor shall conform to the following Indian/International Standards, which shall mean latest revisions, with amendments/changes adopted and published, unless specifically stated otherwise in the Specification.
- 2.14.2 In the event of the supply of conductor conforming to standards other than specified, the Bidder shall confirm in his bid that these standards are equivalent to those specified. In case of award, salient features of comparison between the standards proposed by the supplier and those specified in this document will be provided by the supplier to establish their equivalence.

| Sl. No. | Indian Standard | Title | International Standard |
|---------|-----------------|---|------------------------|
| 1. | IS: 209 | Specification for zinc | BS:3436 |
| 2. | IS: 398 Part-I | Specification for Aluminium Conductors for Overhead Transmission Purposes | IEC:61089 BS:215 |
| 3. | IS:398 Part-II | Aluminum Conductor Galvanised Steel Reinforced | BS:215 IEC:61089 |
| 4. | IS:398 Part-V | Aluminum Conductor Galvanised Steel- Reinforced For Extra High Voltage (400 KV) and above | IEC:61089 BS:215 |



| | | | |
|-----|-----------|---|---------------------------------|
| 5. | IS : 1778 | Reels and Drums for Bare Conductors | BS:1559 |
| 6. | IS : 1521 | Method of Tensile Testing of Steel Wire | ISO 6892 |
| 7. | IS : 2629 | Recommended Practice for Hot Dip Galvanising of Iron and Steel | |
| 8. | IS : 2633 | Method of Testing Uniformity of Coating on Zinc Coated Articles | |
| 9. | IS : 4826 | Galvanised Coating on Round Steel Wires | IEC : 60888 BS:443 |
| 10. | IS : 6745 | Methods of Determination of Weight of Zinc Coating of Zinc Coated Iron and Steel Articles | BS:433 ISO 1460 |
| 11. | IS : 8263 | Method of Radio Interference Tests on High Voltage Insulators | IEC: 60437 NEMA:107 CISPR |
| 12. | | Zinc Coated steel wires for stranded Conductors | IEC : 60888 |
| 13. | | Hard drawn Aluminium wire for overhead line conductors | IEC : 60889 |

The standards mentioned above are available from:

| Reference Abbreviation | Name and Address |
|------------------------|---|
| BS | British Standards, British Standards Institution 101, Pentonville Road, N - 19-NDUK |
| IEC/CISPR | International Electro technical Commission, Bureau Central de la Commission, electro Technique international, 1 Rue de verembe, Geneva SWITZERLAND |
| BIS/IS | Beureau Of Indian Standards. Manak Bhavan, 9, Bahadur Shah Zafar Marg, New Delhi - 110001. INDIA |



| | |
|------|--|
| ISO | International Organisation for Standardization. Danish Board of Standardization Danish Standardizing Sraat, Aurehoegvej-12 DK-2900, Heeleprup, DENMARK. |
| NEMA | National Electric Manufacture Association, 155, East 44th Street. New York, NY 10017 U.S.A. |





Annexure-A

Standard Technical Particulars for ACSR Conductors

| Sl. | Description | Unit | Standard Technical Particulars Conductors | | | | | |
|-----|------------------------------------|------|--|----------------------|----------------------|--------------------|-----------------------|---------------------|
| | | | ACSR LAPWIN G | ACSR BERSIMI S | ACSR SNOWBIR D | ACSR MOOSE E | ACS R ZEBR A | ACSR PANTHE R |
| 1.0 | Construction | | | | | | | |
| 1.1 | Stranding and wire diameter | | | | | | | |
| a) | Aluminium wire | | 45/4.78 mm | 42/4.57 mm | 42/3.99 mm | 54/3.53 mm | 54/3.18 mm | 30/3.00 mm |
| b) | Steel wire | | 7/3.18 mm | 7/2.54 mm | 7/2.21 mm | 7/3.53 mm | 7/3.18 mm | 7/3.00 mm |
| 1.2 | Layer & no. of wire | | | | | | | |
| a) | Steel core | | 1 | 1 | 1 | 1 | 1 | 1 |
| b) | 1st steel layer | | 6 | 6 | 6 | 6 | 6 | 6 |
| c) | 1st Aluminium layer | | 9 | 8 | 8 | 12 | 12 | 12 |
| d) | 2nd Aluminium layer | | 15 | 14 | 14 | 18 | 18 | 18 |
| e) | 3rd Aluminium layer | | 21 | 20 | 20 | 24 | 24 | NA |
| 2.0 | Raw Materials | | | | | | | |
| 2.1 | Aluminium | | | | | | | |
| a) | Minimum purity of Aluminium | % | 99.50 | | | | | |
| b) | Maximum copper content | % | 0.04 | | | | | |



| | | | | | | | | |
|-----|---|-----|---------------------|----------|----------|----------|----------|----------|
| 2.2 | Steel wires/ rods | | | | | | | |
| a) | Carbon | % | 0.50 to 0.85 | | | | | |
| b) | Manganese | % | 0.50 to 1.10 | | | | | |
| c) | Phosphorous | % | Not more than 0.035 | | | | | |
| d) | Sulphur | % | Not more than 0.045 | | | | | |
| e) | Silicon | % | 0.10 to 0.35 (Max.) | | | | | |
| 2.3 | Zinc | | | | | | | |
| a) | Minimum purity of Zinc | .% | 99.95 | | | | | |
| 3.0 | Aluminum strands after stranding | | | | | | | |
| 3.1 | Diameter | | | | | | | |
| a) | Nominal | mm | 4.78 | 4.57 | 3.99 | 3.53 | 3.18 | 3.00 |
| b) | Maximum | mm | 4.81 | 4.60 | 4.02 | 3.55 | 3.20 | 3.02 |
| c) | Minimum | mm | 4.75 | 4.54 | 3.96 | 3.51 | 3.16 | 2.98 |
| 3.2 | Minimum breaking load of strand | | | | | | | |
| a) | Before stranding | KN | 2.87 | 2.64 | 2.12 | 1.57 | 1.29 | 1.17 |
| b) | After stranding | KN | 2.73 | 2.51 | 2.02 | 1.49 | 1.23 | 1.11 |
| 3.3 | Max.resistance of 1 m length of strand at 20 deg. C | Ohm | 0.001595 | 0.001746 | 0.002295 | 0.002921 | 0.003604 | 0.004053 |
| 4.0 | Steel strand after stranding | | | | | | | |
| 4.1 | Diameter | | | | | | | |
| a) | Nominal | mm | 3.18 | 2.54 | 2.21 | 3.53 | 3.18 | 3.00 |
| b) | Maximum | mm | 3.24 | 2.59 | 2.25 | 3.59 | 3.24 | 3.06 |



| | | | | | | | | | | | | | | |
|-----|--|--------|------------------------------------|-----------------|---------|------------------------------------|---------|-------|---------|-----|---------|-----|-----|-----|
| c) | Minimum | mm | 3.12 | 2.49 | 2.17 | 3.47 | 3.12 | 2.94 | | | | | | |
| 4.2 | Minimum breaking load of strand | | | | | | | | | | | | | |
| a) | Before stranding | KN | 10.43 | 6.87 | 4.74 | 12.86 | 10.43 | 9.29 | | | | | | |
| b) | After stranding | KN | 9.91 | 6.53 | 4.49 | 12.22 | 9.91 | 8.83 | | | | | | |
| 4.3 | Galvanising | | | | | | | | | | | | | |
| a) | Minimum weight of zinc coating per sq.m. | gm | 250 | 230 | 230 | 250 | 250 | 240 | | | | | | |
| b) | Minimum number of dips that the galvanised strand can with stand in the standard preece test | Nos. | 2 of one minute & 1 of half minute | 2 of one minute | | 2 of one minute & 1 of half minute | | | | | | | | |
| c) | Min. No. of twists in guage length equal 100 times the dia. of wire which the strand can withstand in the torsion test (after stranding) | Nos | 16 | 16 | 16 | 16 | 16 | 16 | | | | | | |
| 5.0 | Stranded Conductor | | | | | | | | | | | | | |
| 5.1 | Overall diameter | mm | 38.22 | 35.04 | 30.57 | 31.77 | 28.62 | 21.00 | | | | | | |
| 5.2 | Sectional area of Aluminium | sq. mm | 807.5 | 688.9 | 525.2 | 528.5 | 428.9 | 212.1 | | | | | | |
| 5.3 | Total sectional area | sq. mm | 863.1 | 724.4 | 552.1 | 597.0 | 484.5 | 261.5 | | | | | | |
| 5.4 | Minimum UTS of the conductor | kN | 188.0 | 154.0 | 118.0 | 161.20 | 130.32 | 89.67 | | | | | | |
| 5.5 | Lay length of outer steel layer | | Max | Min | Ma x | Min | Ma x | Min | Ma x | Min | Ma x | Min | Max | Min |
| a) | 1st steel layer | mm | 30 | 18 | 24 | 16 | 24 | 16 | 18 | 16 | 18 | 13 | 28 | 16 |
| b) | 1st Aluminium layer | mm | 17 | 10 | 16 | 10 | 16 | 10 | 14 | 12 | 17 | 10 | 16 | 10 |



| | | | | | | | | | | | | | | |
|------|--|--------|------------|----|---------|----|---------|----|---------|----|---------|----|--------|----|
| c) | 2nd Aluminium layer | mm | 16 | 10 | 16 | 10 | 16 | 10 | 13 | 11 | 16 | 10 | 14 | 10 |
| d) | 3rd Aluminium layer | mm | 13 | 10 | 13 | 10 | 14 | 10 | 12 | 10 | 14 | 10 | NA | NA |
| 5.6 | DC resistance of the conductor at 20°C | ohm/km | 0.0358 | | 0.04242 | | 0.05516 | | 0.05552 | | 0.06868 | | 0.1390 | |
| 5.7 | Standard length of the conductor | m | 1800 | | 2100 | | 2100 | | 2100 | | 2200 | | 2300 | |
| 5.8 | Tolerance on Standard length | % | (±) 5 | | | | | | | | | | | |
| 5.9 | Direction of lay of outer layer | | Right Hand | | | | | | | | | | | |
| 5.10 | Linear mass of the conductor | | | | | | | | | | | | | |
| a) | Standard | kg/km | 2667 | | 2181 | | 1657 | | 2004 | | 1621 | | 974 | |
| b) | Minimum | kg/km | 2628 | | 2142 | | 1632 | | 1969 | | 1589 | | 954 | |
| c) | Maximum | kg/km | 2707 | | 2221 | | 1682 | | 2040 | | 1653 | | 993 | |



ANNEXURE-B**1. Tests on Conductor****1.1 D.C. Resistance Test on Stranded Conductor**

On a conductor sample of minimum 5m length two contact-clamps shall be fixed with a predetermined bolt torque. The resistance shall be measured by a Kelvin double bridge or digital ohm-metre of sufficient accuracy by placing the clamps initially zero metre and subsequently one metre apart. The test shall be repeated at least five times and the average value recorded. The value obtained shall be corrected to the value at 20⁰C as per IS:398. The resistance corrected at 20⁰C shall conform to the requirements indicated in the STP.

1.2 UTS Test on Stranded Conductor

Circles perpendicular to the axis of the conductor shall be marked at two places on a sample of conductor of minimum 5 m length between fixing arrangement suitably fixed on a tensile testing machine. The load shall be increased at a steady rate upto 50% of minimum specified UTS and held for one minute. The circles drawn shall not be distorted due to relative movement of strands. Thereafter the load shall be increased at steady rate to 100% of the UTS of conductor and held for one minute. The Conductor sample shall not fail during this period. The applied load shall then be increased until the failing load is reached and this value shall be recorded.

1.3 Corona Extinction Voltage Test

The sample assembly with each conductor of 5 m length shall be strung as per the configuration shown in the Table below:

| Line Configuration | No of conductors per Bundle | Sub-conductor Spacing (mm) | Maximum Height of the conductor above ground (m) | Minimum Corona extinction voltage (kV) |
|--|-----------------------------|----------------------------|--|--|
| 220 kV with ACSR ZEBRA conductor | 1 | N.A. | 7 | 154 |
| 400 kV with twin ACSR MOOSE conductor | 2 | 450 | 8.84 | 320 |
| 400 kV with twin ACSR LAPWING conductor | 2 | 450 | 8.84 | 320 |
| 400 kV with Triple ACSR SNOWBIRD conductor | 3 | 457 | 8.84 | 320 |
| 400 kV with Quad ACSR MOOSE conductor | 4 | 457 | 8.84 | 320 |
| 765 kV with Quad ACSR BERSIMIS conductor | 4 | 457 | 15 | 510 |

| Line Configuration | No of conductors per Bundle | Sub-conductor Spacing (mm) | Maximum Height of the conductor above ground (m) | Minimum Corona extinction voltage (kV) |
|--|-----------------------------|----------------------------|--|--|
| 765 kV with Hexa ACSR ZEBRA conductor | 6 | 457 | 15 | 510 |
| ±500 kV HVDC Bipole line with Quad ACSR LAPWING/BERSIMIS conductor | 4 | 457 | 12.5 * | 550 |
| ±800 kV HVDC Bipole line with Hexa ACSR LAPWING conductor | 6 | 457 | 18 * | 880 |

* Height shall be suitably adjusted so as to achieve a surface gradient of 22 kV/cm on the conductors.

The sample assembly when subjected to power frequency/dc voltage under dry condition shall have a corona extinction voltage of not less than the values indicated in the table above. There shall be no evidence of corona on any part of the samples. The test should be conducted without corona control rings. However, small corona control rings may be used to prevent corona in the end fittings. The atmospheric conditions during testing shall be recorded and test results should be corrected for standard atmospheric conditions.

1.4 Radio Interference Voltage Test

Under the conditions as specified under (1.2) above, the conductor samples shall have radio interference voltage below 1000 microvolts. This test may be carried out with corona control rings and arcing horns. The test procedure shall be in accordance with IEC-60437.

1.5 Visual and Dimensional Check on Drums

The drums shall be visually and dimensionally checked to ensure that they conform to the requirements of this Specification.

1.6 Visual Check for Joints, Scratches etc. and length measurement of conductor by rewinding

Conductor drums shall be rewound in the presence of the Employer. The Employer shall visually check for scratches, joints etc. and that the conductor generally conform to the requirements of this Specification. One drum out of ten drums or part thereof from each lot shall be rewound in the presence of the Employer's representative.

1.7 Measurement of diameters of individual Steel and Aluminium strands

The diameters of the individual strands shall be checked to ensure that they conform to the requirement of this Specification.

1.8 Check for Lay-ratios of Various Layers

The lay-ratios of various layers shall be checked to ensure that they conform to the requirements of this Specification.

1.9 Galvanizing Test

The test procedure shall be as specified in IEC 60888. The material shall conform to the requirements of this Specification. The adherence of zinc shall be checked by wrapping around a mandrel four times the diameter of steel wire.

1.10 Torsion and Elongation Tests on Steel Strands

The test procedures shall be as per clause No. 10.3 of IEC 60888. In torsion test, the number of complete twists before fracture shall not be less than that indicated in the STP. In case test sample length is less or more than 100 times the stranded diameter of the strand, the minimum number of twists will be proportioned to the length and if number comes in the fraction then it will be rounded off to next higher whole number. In elongation test, the elongation of the strand shall not be less than 3.5% for a gauge length of 250 mm after stranding.

1.11 Procedure Qualification test on welded Aluminium

Two Aluminium wire shall be welded as per the standard quality plan and shall be subjected to tensile load. The breaking strength of the welded joint of the wire shall not be less than the breaking strength of individual strands.

1.12 Drum Strength Test of Wooden Drums

The details regarding Drum strength test will be discussed and mutually agreed to by the supplier & Employer as per the Standard Quality Assurance Plan.

1.13 Barrel Batten Strength Test of Wooden Drums

The details regarding barrel batten strength test will be discussed and mutually agreed to by the supplier & Employer as per the Standard Quality Assurance Plan.

1.14 Chemical Analysis of Zinc

Samples taken from the zinc ingots shall be chemically/ spectrographically analyzed. The same shall be in conformity to the requirements stated in the Specification.

1.15 Chemical Analysis of Aluminium

Samples taken from the aluminium ingots/rods shall be chemically/ spectrographically analyzed. The same shall be in conformity to the requirements stated in the Specification.

1.16 Chemical Analysis of Steel

Samples taken from the steel rods shall be chemically/ spectrographically analyzed. The same shall be in conformity to the requirements stated in the Specification.



Drawings of Drum

NOTE :

1. ALL DIMENSIONS ARE IN MM.
2. DRUMS SHALL GENERALLY CONFIRM TO IS 1778-1980
AMMENDMENT No.1 Of June 1989 EXCEPT OTHERWISE SPECIFIED.
3. ONE LENGTH OF CONDUCTOR SHALL BE WOUND ON EVERY DRUM
4. THE STANDARD LENGTH OF THE CONDUCTOR AND EQUIVALENT SIZE OF CONDUCTOR IS L mtrs (INDICATED IN THE TABLE BELOW) WITH TOLERANCE OF ± 5%.
5. TOLERANCE ON DIMENSIONS OF WOOD IS + 3mm.
6. TOLERANCE ON STEEL COMPONENTS OF THE DRUM IS ± 0.50mm.
7. INNER & OUTER SURFACE OF FLANGE & BARREL SHALL BE BITUMIN PAINTED.
8. BARREL & INNER SURFACE OF FLANGE SHALL HAVE WATER PROOF HDPE SHEET
9. OUTER SURFACE OF CONDUCTOR SHALL BE COVERED BY WATER PROOF POLYTHENE PAPER
10. MEDIUM GRADE CRAFT/CREPE/POLYTHENE PAPER SHALL BE USED IN BETWEEN THE LAYERS
11. ALL NUTS OF ROD SHOULD BE TACK WELDED.
12. 3 nos. BINDER SHALL BE USED FOR BINDING THE EXTERNAL LAGGING.
13. FLANGE SHALL BE NAILED IN 5 CIRCLES WITH NAIL SIZE OF 125X4.

| | DRUM COMPONENTS | MATERIAL SPECIFICATION | QUANTITY | DIMENSION |
|----|-----------------------|------------------------|----------|-------------------|
| 1. | FLANGE | SEASONED WOOD | 2 | ∅ 1500x100(50+50) |
| 2. | BARREL END SUPPORTS | SEASONED WOOD | 2 | ∅ 500x50 |
| 3. | BARREL MIDDLE SUPPORT | SEASONED WOOD | 1 | ∅ 500x100(50+50) |
| 4. | OUTER LAGGING | SEASONED WOOD | -- | 1150x50 |
| 5. | BARREL BATTENS | SEASONED WOOD | -- | 950x75x50 |
| 6. | SPINDLE PLATE | MS | 2 | 300x300x8 |
| 7. | BUSH PLATE STUD | MS | 8 | ∅ 16x180 |
| 8. | TIE ROD | MS | 6 | ∅ 22x1225 |
| 9. | TIE ROD WASHER | MS | 12 | 75x75x6 |
| | | | | |
| | | | | |

| | | | |
|---------------------------|--------------|---|--|
| STANDARD CONDUCTOR LENGTH | ACSR PANTHER | SAPDC PVT. LTD. (A WHOLLY OWNED SUBSIDIARY OF SJVN LTD.) | |
| L in Meters | 2300 | | |

| REVISION | | | | | CLEARED BY | | | TITLE | |
|----------|-------------|------|-------|------|------------|----------|----------|--|------|
| | | | | | | | | WOODEN DRUM DRAWING FOR ACSR PANTHER CONDUCTOR | |
| REV. No | DESCRIPTION | CHKD | REVWD | APPD | CHECKED | REVIEWED | APPROVED | SCALE N.T.S. | REV. |
| | | | | | | | | DRAWING NO:CC:ENGG-IL:COND:WD | 0 |

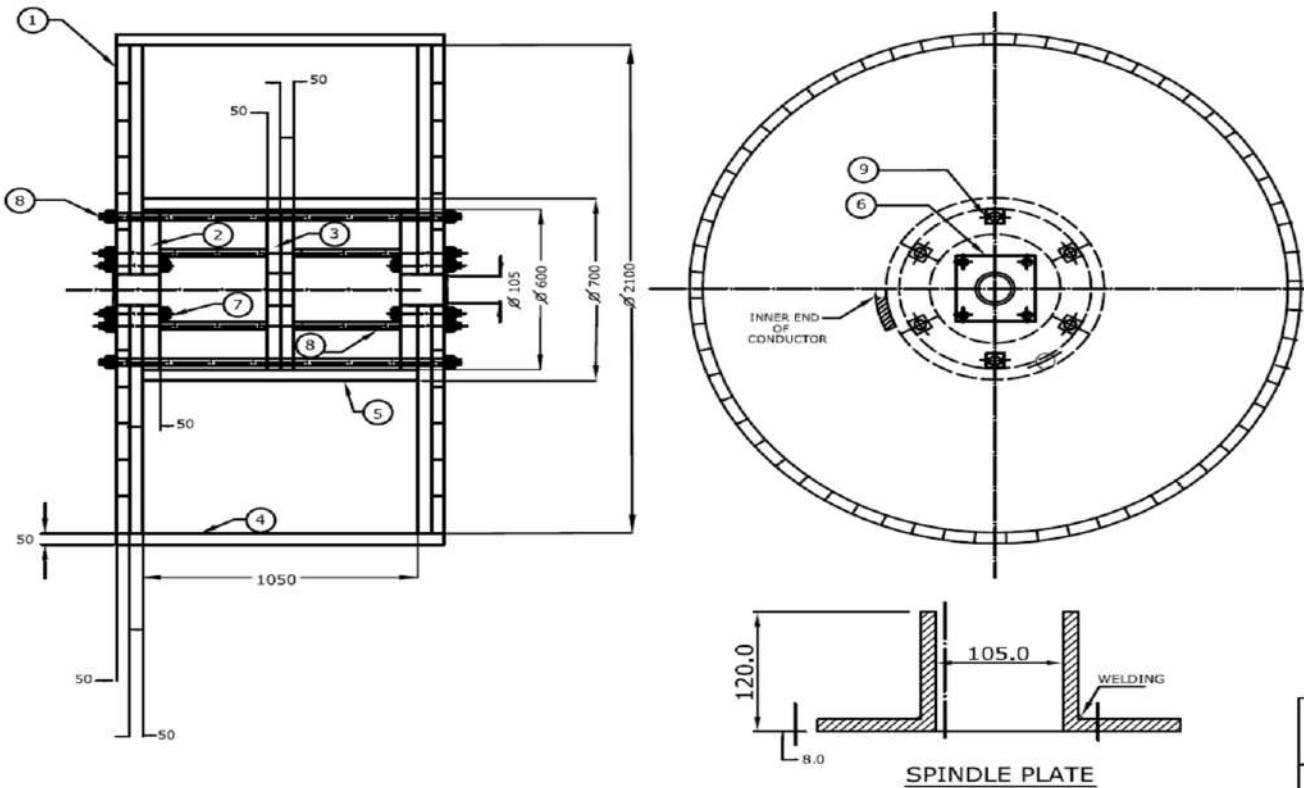

NOTE :

1. ALL DIMENSIONS ARE IN MM.
2. DRUMS SHALL GENERALLY CONFIRM TO IS 1778-1980 AMMENDMMT No.1 Of June 1989 EXCEPT OTHERWISE SPECIFIED.
3. ONE LENGTH OF CONDUCTOR SHALL BE WOUND ON EVERY DRUM
4. THE STANDARD LENGTH OF THE CONDUCTOR AND EQUIVALENT SIZE OF CONDUCTOR IS L mtrs (INIDCATED IN THE TABLE BELOW) WITH TOLERANCE OF ± 5%.
5. TOLERANCE ON DIMENSIONS OF WOOD IS + 3mm.
6. TOLERANCE ON STEEL COMPONENTS OF THE DRUM IS ± 0.50mm.
7. INNER & OUTER SURFACE OF FLANGE & BARREL SHALL BE BITUMIN PAINTED.
8. BARREL & INNER SURFACE OF FLANGE SHALL HAVE WATER PROOF HDPE SHEET
9. OUTER SURFACE OF CONDUCTOR SHALL BE COVERED BY WATER PROOF POLYTHENE PAPER
10. MEDIUM GRADE CRAFT/CREPE/POLYTHENE PAPER SHALL BE USED IN BETWEEN THE LAYERS
11. ALL NUTS OF ROD SHOULD BE TACK WELDED.
12. 3 nos. BINDER SHALL BE USED FOR BINDING THE EXTERNAL LAGGING.
13. FLANGE SHALL BE NAILED IN 5 CIRCLES WITH NAIL SIZE OF 125X4.

STANDARD DRAWING

| STANDARD CONDUCTOR LENGTH | ACSR LAPWING | ACSR BERSIMIS | ACSR MOOSE | ACSR SNOWBIRD | ACSR ZEBRA |
|---------------------------|--------------|---------------|------------|---------------|------------|
| L In Meters | 1800 | 2100 | 2100 | 2100 | 2200 |

| | DRUM COMPONENTS | MATERIAL SPECIFICATION | QUANTITY | DIMENSION |
|----|-----------------------|------------------------|----------|-------------------|
| 1. | FLANGE | SEASONED WOOD | 2 | ∅ 2100x100(50+50) |
| 2. | BARREL END SUPPORTS | SEASONED WOOD | 2 | ∅ 600x50 |
| 3. | BARREL MIDDLE SUPPORT | SEASONED WOOD | 1 | ∅ 600x100(50+50) |
| 4. | OUTER LAGGING | SEASONED WOOD | -- | 1250x50 |
| 5. | BARREL BATTENS | SEASONED WOOD | -- | 1050x75x50 |
| 6. | SPINDLE PLATE | MS | 2 | 300x300x8 |
| 7. | BUSH PLATE STUD | MS | 8 | ∅ 16X180 |
| 8. | TIE ROD | MS | 6 | ∅ 22X1325 |
| 9. | TIE ROD WASHER | MS | 12 | 75x75x6 |

SAPDC PVT. LTD.
(A WHOLLY OWNED SUBSIDIARY OF SJVN LTD.)

TITLE
WOODEN DRUM DRAWING FOR CONDUCTOR

CLEARED BY

| | | | | | |
|---------|----------|----------|-----------------|-------------------------------|-----------|
| CHECKED | REVIEWED | APPROVED | SCALE N.T.S. | DRAWING NO:CC-ENGG-TL-COND-WD | REV. 0 |
|---------|----------|----------|-----------------|-------------------------------|-----------|

ANNEXURE C

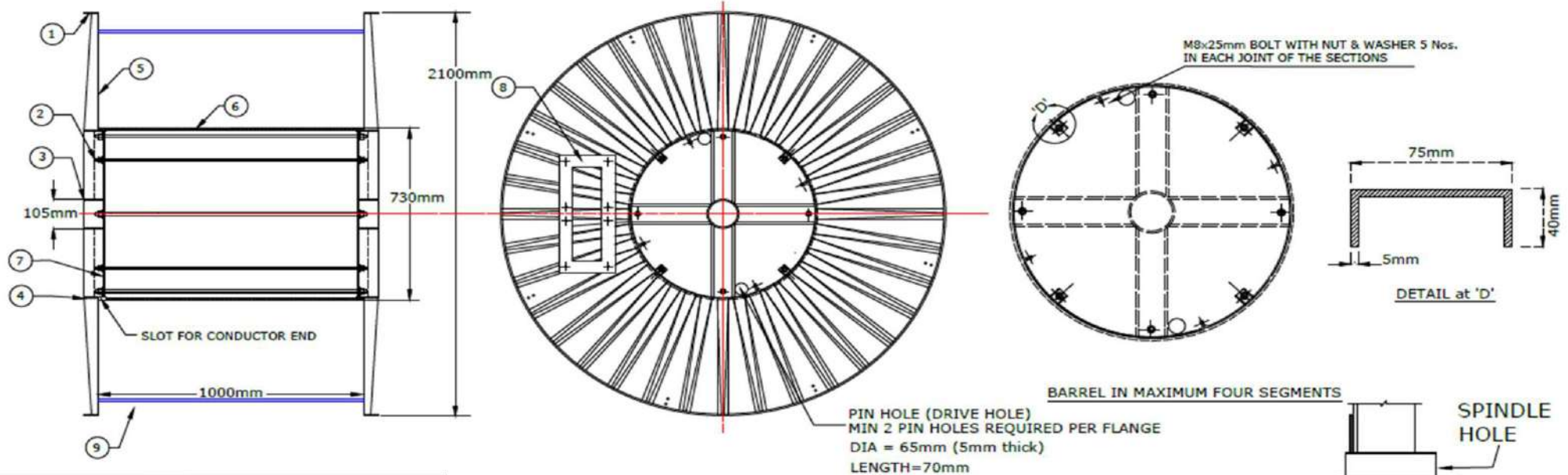

NOTE :

| | |
|--------|--|
| (i) | Flanges shall have non corrosive primer coat and enamel paint . |
| (ii) | Washers are required on all bolts. |
| (iii) | Barrel and inner surface of flange shall have water proof protective HDPE sheet. |
| (iv) | Tolerance overall :+5mm. |
| (v) | Tolerance on sheet metal :+0.1mm. |
| (vi) | Tolerance on other M.S items :+3mm. |
| (vii) | Tolerance on thickness for other M.S items :+0.5mm. |
| (viii) | Tolerance on bush :+2mm. |
| (ix) | All dimensions are in mm |
| (x) | All mild steel shall conform to IS-2062 |

| | Name of the Parts | Material Specification | Quantity | Dimensions |
|---|-------------------------|------------------------|------------------------------------|--|
| 1 | OUTER RING | M.S.PLATE | 2 | 63x8 mm (FLAT RING) |
| 2 | TIE ROD | M.S.ROD | 8 | 18 mm DIA |
| 3 | CENTRE BUSH | M.S.PIPE | 2 | 105 mm IDx115 mm OD |
| 4 | INNER RING | M.S.PLATE | 2 | 100x6 mm |
| 5 | FLANGE | H.R.SHEET | Max 3 CORRUGATED SHEETS PER FLANGE | 1.6 mm THICK (min 36 nos. of corrugations) |
| 6 | BARREL SHEET | H.R.SHEET | Max 4 SEGMENTS | 2.5 mm THICK |
| 7 | CROSS ARM | MILD STEEL | 4 | 100mmx70mm,6mm THICK |
| 8 | FRAME SIZE(FOR MARKING) | | | 250mmx400mm (APPROX) |
| 9 | SOLID PP SHEET | POLY PROPYLENE | | 5 mm THICK (min) |

STANDARD DRAWING

| STANDARD CONDUCTOR LENGTH | ACSR LAPWING | ACSR BERSIMIS | ACSR MOOSE | ACSR SNOWBIRD | ACSR ZEBRA | ACSR PANTHER |
|---------------------------|--------------|---------------|------------|---------------|------------|--------------|
| L in Meters | 1800 | 2100 | 2100 | 2100 | 2200 | 2300 |

| REVISION | | | | CLEARED BY | | | TITLE | | SCALE N.T.S. | DRAWING NO.CO/ENGG/TL/COND/WD | REV. 0 |
|----------|-------------|------|-------|------------|---------|----------|----------|---------------------------------|--------------|-------------------------------|--------|
| REV. No | DESCRIPTION | CHKD | REVWD | APPD | CHECKED | REVIEWED | APPROVED | STEEL DRUMDRAWING FOR CONDUCTOR | | | |

SAPDC PVT. LTD.
(A WHOLLY OWNED SUBSIDIARY OF SJVN LTD.)

| | |
|--|----------------------------|
| Volume-II : Technical Specification | |
| Section-III | MANUFACTURING QUALITY PLAN |



| STANDARD MANUFACTURING QUALITY PLAN (SMQP) FOR MULTISTRAND ACSR & AAC CONDUCTOR | | | |
|--|--|---|--|
| C/QA/SMQP/ACSR/AAC-Rev 00 | | | |
| Code 1 | | Indicates place where testing is planned to be performed i.e. Inspection location. | Code 2 |
| A | At conductor manufacturer's works | | J |
| B | At Component manufacturer's works | | K |
| C | At authorized distributors place | | L |
| D | At independent Lab. | | M |
| E | At turn key contractor's location | | |
| F | Not Specified | | |
| Code 3 | | Indicates who shall witness the tests i.e. Witnessing Agency | Code 4 |
| P | Component Manufacturer | | W |
| Q | Component Manufacturer and conductor Manufacturer | | X |
| R | Component Manufacturer, Conductor Manufacturer and Contractor | | Y |
| S | Conductor Manufacturer | | Z |
| T | Conductor Manufacturer and Contractor | | |
| U | Conductor Manufacturer, and/or Contractor and SAPDC | | |
| V | Third Party | | |
| Code 5 | | Whether specific approval of sub-vendor / component make envisaged? | Code 6 |
| E | Envisaged | | Y |
| N | Not Envisaged | | N |
| | | | Code 6 |
| | | | Whether test records required to be submitted after final inspection for issuance of CIP/MICC |
| | | | Y |
| | | | N |

Component Manufacturer- Aluminium ingot/wire rod and galvanized steel wire supplier



**STANDARD MANUFACTURING QUALITY PLAN (SMQP) FOR MULTISTRAND ACSR & AAC CONDUCTOR
C/QA/SMQP/ACSR/AAC-Rev 00**



NOTES :

- 1 Proper co-relation of materials with test certificates from Raw Material stage to finished conductor shall be maintained.
- 2 The Aluminium Ingots/aluminium wire rods shall be procured from SAPDC approved sources / LME registered manufacturers. Aluminium ingot to aluminium wire rod conversion from any conversion agent/ conductor manufacturer's own facility needs to be approved by SAPDC. The record shall be reviewed as per their plan standard by SAPDC during product inspection/process audits.
- 3 The conductor manufacturer shall furnish the test certificates of aluminium ingot/ Y rod for review by SAPDC.
- 4 Galvanized Steel Wire to be procured from SAPDC approved sources and the conductor manufacturer shall furnish the following test certificates from steel wire manufacturer for review by SAPDC :
 - Chemical Test Certificate of Steel Wire Rod issued by its Manufacturer
 - Test Certificate of Zinc issued by its Manufacturer
 - Test certificates of the tests carried out by steel wire manufacturer on finished steel wire.
- 5 The conductor manufacturer will carry out the acceptance test on aluminium and steel strands on 20% of the drums offered for inspection and will submit the records at the time of SAPDC inspection.
- 6 Adequate care shall be taken to avoid damages to galvanising during preforming and post forming operations.
- 7 Valid calibration certificates of various testing and measuring instrument / equipments by NABL accredited as per agencies and standard resistance for verification of resistance bridges shall be available at conductor manufacturer works. Deepak Cable shall inform SAPDC regional QA&I office regarding the date of calibration and SAPDC shall physically present during the calibration of the testing equipments and after calibration the testing equipments shall be sealed properly.
- 8 The area where conductor is to be manufactured (stranding m/c & rewinding m/c) shall be covered with rubber mat/ coir mat/ Wooden floor, etc.
- 9 All guides, rollers, pulleys etc. used for manufacturing conductor shall be of Nylon/ Hylum/ Teflon or other soft material instead of steel.
- 10 Finished conductor shall be checked for length verification and surface finish on separate rewinding machine at variable speed from 8 to 16 mtr/ minute. The rewinding facilities shall have appropriate clutch system and shall be free from vibration and jerks etc. with traverse laying facilities. If conductor length is found less than the declared length during rewinding, then two drums from the same lot shall be verified for declared length. In case any of these drums are found have less length, the lot will be rejected and if these two drums' length matches the declared length, whole lot shall be accepted after deduction of length as observed for first case in rest of the drums. In case of defects in surface finish, additional two drums shall be taken for rewinding & if problem is observed, in any of the two drums the entire lot shall be rejected.
- 11 The conductor manufacturer shall maintain records of the joints in inner layer of the conductor for all the drums and shall submit the records to SAPDC for review at the time of Inspection.
- 12 Conductor sealing shall be as per approved sealing procedure. The conductor ends are required to be sealed with heat shrinkable sleeves and shall be properly secured with the drum by "U" clamps (nail) after covering the conductor with PVC adhesive tape to avoid loosening of conductor layers during transit and handling.
- 13 The drums shall be suitable for wheel mounting and letting off the conductor under minimum controlled tension of the order of 5 KN.
- 14 The inner check of the flanges and drum barrels surface shall be painted with bitumen based paint ; Before reeling thick bituminized water proof bamboo paper shall be secured on the drum barrel and inside of the flanges of the drum. After reeling the conductor, the exposed surface of the outer layer of the conductor shall be wrapped with water proof thick bituminized bamboo paper than transparent plastic sheet.
- 15 The wood used in the drum shall preferably be neutral (open corisive) with pH (aqueous extract) 5.5 - 7.5 and the wood preservative copper used compound.
- 16 The manufacturer may supply the conductor in returnable/non-returnable (as per TS) painted steel drums. After preparation of steel surface according to IS 9954, synthetic enamel paint shall be applied after one coat of primer.



**STANDARD MANUFACTURING QUALITY PLAN (SMQP) FOR MULTISTRAND ACSR & AAC CONDUCTOR
C/QA/SMQP/ACSR/AAC-Rev 00**



- 17 Conductor manufacturer has to ensure marking of CIP/ MICC no. on all drums before dispatch and a copy of CIP/ MICC along with the test reports should be sent to the site along with the dispatches.
- 18 The Lay ratio of any Aluminium layer shall not be greater than the lay ratio of Aluminium layer immediately beneath it.
- 19 The MQP should be in conjunction with the applicable technical specification against which the conductor is being manufactured and in case any contradiction between technical specification/ approved drawing and MQP detailed mentioned in technical specification and approved drawing shall be final.
- 20 **The conductor manufacturer shall carry out process audits on quarterly basis at galvanized steel wire manufacturer works as per approved MQP of steel wire.**
The audit report shall be made available for SAPDC review during product inspection/process audits.
- 21 IS-398 part 2 is for below 400kV line and it is used for manufacturing ACSR Zebra, ACSR Panther and ACSR Dog etc.
IS-398 part 5 for 400kV and above line, it is used for manufacturing ACSR Moose, ACSR Snowbud, ACSR Betsimis, ACSR Lapwing, etc.
- 22 Standard length & random length of conductor shall be governed as specified in SAPDC technical specification.
- 23 Rejection & retests shall be as per IS 398 part 5.
In case of rejection of the offered lot of conductor/earthwire after testing as per MQP/Technical Specification/IS, the rejected material and the samples already tested shall be scrapped and strictly disposed off as follows:
 - a) The rejected lot/tested samples shall be clearly identified and stored separately to avoid any mix up with any in-process/finished lot till the same is disposed off.
 - b) The supplier shall arrange for cutting of the rejected conductor/earthwire lot in bits & pieces which shall be sold as scrap.
 - c) In case supplier intends to dispose off rejected material through any other mode, the same shall be done with approval of Corporate QA&I Department.
 - d) Necessary supporting documents in regard to (b) and (c) above, shall be submitted for verification of SAPDC and record shall be maintained at manufacturer's works.
- 24 The size & acceptance test criteria for different types of conductor shall be as per approved GTP.
- 25 **This MQP is applicable for AAC (All Aluminum Conductors) also. However, for AAC, all tests pertaining to steel shall not be applicable.**



| STANDARD MANUFACTURING QUALITY PLAN (SMQP) FOR MULTISTRAND ACSR & AAC CONDUCTOR C/QA/SMQP/ACSR/AAC-Rev 00 | | | | | | | | | | | | | |
|--|--|------------------|---|---|---|---|------------------|----------|----------|--------|--------|--------|---------|
| Sr. No. | Components/ Operations & Description of Test | Type of Check | Quantum of Check/ Sampling with basis | Reference document for Testing | Acceptance Norms | Format of Record | Applicable Codes | | | | | | Remarks |
| | | | | | | | 1 | 2 | 3 | 4 | 5 | 6 | |
| A. Section: RAW MATERIAL INSPECTION | | | | | | | | | | | | | |
| 1.1 Aluminium Ingot | | | | | | | | | | | | | |
| 1.1.1 | Chemical Composition | Spectro Analysis | 1 sample per heat of 9 MT or furnace capacity and part thereof One sample/lot of 100 MT or part thereof per supplier shall be tested | Suppliers TC IS 4026 and SAPDC Spec. | AL 99.5 % (min) Cu 0.04 % (max) Other elements as per GTP | Suppliers TC/ Manufacturer format of record (MFOR) | B A | K J | P S | W Z | E N | N N | |
| 1.2 Aluminium Wire Rod | | | | | | | | | | | | | |
| 1.2.1 | Chemical Composition | Spectro Analysis | 1 sample per heat of 9 MT or furnace capacity and part thereof One sample/lot of 100 MT or part thereof per supplier shall be tested | Suppliers TC IS 4026 and SAPDC Spec. | AL 99.5% (min) Cu 0.04 % (max) Other elements as per GTP | Suppliers TC/ Manufacturer format of record (MFOR)/TPL | B A/D | K J/L | P S/V | W Z | E N | N N | |
| 1.2.2 | Diameter | Dimensional | 1 sample from each coil. | IS 5484 and SAPDC Spec. | Min. 9.00 mm, Nom. 9.50mm Max. 10.00 mm | Supplier TC & MFOR | A/B | J/K | S/P | Z | - | N | |
| 1.2.3 | Tensile Strength | Mechanical | 1 sample from each coil. | IS 5484 and SAPDC Spec. | Min. 10.50 to 12 Kg/mm ² for A1 strands dia less than 4 mm and 11.5 kg/mm ² min for strands dia ≥4 mm | Supplier TC & MFOR | A/B | J/K | S/P | Z | - | N | |
| 1.2.4 | Elongation at break | Mechanical | 1 sample from each coil. | IS 5484, IEC 888 and SAPDC Spec. | Min. 8 % at 250 mm gauge length | Supplier TC & MFOR | A/B | J/K | S/P | Z | - | N | |
| 1.2.5 | Resistivity and Conductivity | Electrical | 1 sample from each coil. | IS 5484, IEC 8898 and SAPDC Spec. | Maximum resistivity 0.028264 ohm mm ² /metre at 20°C. Min. Conductivity 61.0 % of IACS. | Supplier TC & MFOR | A/B | J/K | S/P | Z | - | N | |



| STANDARD MANUFACTURING QUALITY PLAN (SMQP) FOR MULTISTRAND ACSR & AAC CONDUCTOR C/QA/SMQP/ACSR/AAC-Rev 00 | | | | | | | | | | | | | |
|--|--|---------------|---|---|---|---------------------------|------------------|--------|--------|--------|--------|--------|---------|
| Sr. No. | Components/ Operations & Description of Test | Type of Check | Quantum of Check/ Sampling with basis | Reference document for Testing | Acceptance Norms | Format of Record | Applicable Codes | | | | | | Remarks |
| | | | | | | | 1 | 2 | 3 | 4 | 5 | 6 | |
| 1.2.6 | Cleanliness and surface smoothness | Visual | 100% on each coil | SAPDC Spec. | The wire rod shall be free from pipes, laps, cracks, kinks, twists, seams & other injurious defects within the limits of good commercial practices. | Supplier TC & MFOR | A/B | J/K | S/P | Z | - | N | |
| 2.1 | High Tensile Galvanized Steel Wire | | | | | | | | | | | | |
| 2.1.1 | Chemical Analysis | Chemical | One sample/lot of 100 MT or part thereof per supplier to be tested on receipt by conductor manufacturer | SAPDC Spec | C 0.50 to 0.85 % Mn 0.50 to 1.10 % Si 0.10 to 0.35 % P 0.035 % (max) S 0.045 % (max) | Supplier TC TPL report | B D | K L | P V | W Z | E - | N N | |
| 2.1.2 | Diameter | Dimensional | 20 % Coils per lot 10% Coils per lot | IS 398 PT-2.PT-5, IEC 888 & SAPDC Spec. | As per Approved Technical specification | Suppliers TC MFOR | B A | K J | P S | Z Z | - - | N N | |
| 2.1.3 | Tensile Strength/ Breaking Load | Mechanical | 20 % Coils per lot 10% Coils per lot | IS 398 PT-2.PT-5, IEC 888 & SAPDC Spec. | As per Approved Technical specification | Suppliers TC MFOR | B A | K J | P S | Z Z | - - | N N | |
| 2.1.4 | Elongation at break | Mechanical | 20 % Coils per lot 10% Coils per lot | IS 398 PT-2.PT-5, IEC 888 & SAPDC Spec. | Min 4.0 % at 250 mm gauge length. | Suppliers TC MFOR | B A | K J | P S | Z Z | - - | N N | |
| 2.1.5 | Torsion Test | Mechanical | 20 % Coils per lot 10% Coils per lot | IS 398 PT-2.PT-5, IEC 888 & SAPDC Spec. | Min 18 twist on a gauge length of 100x diameter of wire | Suppliers TC MFOR | B A | K J | P S | Z Z | - - | N N | |
| 2.1.6 | Wrapping Test | Mechanical | 20 % Coils per lot 10% Coils per lot | IS 398 PT-2.PT-5, IEC 888 & SAPDC Spec. | Wrap-8.unwrap-6 & wrap-6 On a mandrel having diameter equal to 4 x diameter of wire. The wire shall not break. | Suppliers TC MFOR | B A | K J | P S | Z Z | - - | N N | |



| STANDARD MANUFACTURING QUALITY PLAN (SMQP) FOR MULTISTRAND ACSR & AAC CONDUCTOR C/QA/SMQP/ACSR/AAC-Rev 00 | | | | | | | | | | | | | |
|--|--|---------------|--|---|---|------------------|------------------|---|---|---|---|---|---------|
| Sr. No. | Components/ Operations & Description of Test | Type of Check | Quantum of Check/ Sampling with basis | Reference document for Testing | Acceptance Norms | Format of Record | Applicable Codes | | | | | | Remarks |
| | | | | | | | 1 | 2 | 3 | 4 | 5 | 6 | |
| 2.1.7 | Adhesion Test | Mechanical | 20 % Coils per lot | IS 4826 and SAPDC Spec. | The Zinc coating shall remain adherent to the steel wire when wound 10 turns on a mandrel having diameter equal to 4 x The diameter of wire | Suppliers TC | B | K | P | Z | - | N | |
| | | | 10% Coils per lot | | | | A | J | S | Z | | N | |
| 2.1.8 | Preece Test (Dip Test) | Chemical | 20 % Coils per lot | IS 4826 and SAPDC Spec. | As per Approved Technical specification | Suppliers TC | B | K | P | Z | - | N | |
| | | | 10% Coils per lot | | | | A | J | S | Z | | N | |
| 2.1.9 | Mass of Zinc coating | Chemical | 20 % Coils per lot | IS 4826, IS 6745 and SAPDC Spec. | As per Approved Technical specification | Suppliers TC | B | K | P | Z | - | N | |
| | | | 10% Coils per lot | | | | A | J | S | Z | | N | |
| 2.1.10 | Surface finish of GS Wire coils | Visual | 100 % Coils per lot | IS 398, PT-2, PT-5, IEC 888 & SAPDC Spec. | The Wires shall be smooth, uniform and free from imperfections such as spills, splits, scale inclusion, die marks, scratches, abrasion, blow holes etc. | Suppliers TC | B | K | P | Z | - | N | |
| | | | 100 % Coils per lot | | | | A | J | S | Z | | N | |
| 2.1.11 | Check for Joints | Visual | 100 % Coils per lot | IS 398, PT-2, PT-5, IEC 888 & SAPDC Spec. | There shall be NO JOINT | Suppliers TC | B | K | P | Z | - | N | |
| | | | 100 % Coils per lot | | | | A | J | S | Z | | N | |
| 2.1.12 | Purity of Zinc | Chemical | 1 sample for every lot of 100 MT or part thereof | IS 209, IEC 888/1987 and SAPDC Spec. | Min. Purity of Zinc 99.95 % | Suppliers TC | D | L | V | Z | - | N | |



| STANDARD MANUFACTURING QUALITY PLAN (SMQP) FOR MULTISTRAND ACSR & AAC CONDUCTOR C/QA/SMQP/ACSR/AAC-Rev 00 | | | | | | | | | | | | | |
|--|--|------------------------|---|--------------------------------|--|------------------|------------------|---|---|---|---|---|---------|
| Sr. No. | Components/ Operations & Description of Test | Type of Check | Quantum of Check/ Sampling with basis | Reference document for Testing | Acceptance Norms | Format of Record | Applicable Codes | | | | | | Remarks |
| | | | | | | | 1 | 2 | 3 | 4 | 5 | 6 | |
| B. SECTION:IN PROCESS INSPECTION | | | | | | | | | | | | | |
| 3.0 | Aluminium Drawn Wire | | | | | | | | | | | | |
| 3.1 | Diameter of Drawn Aluminium Wire | Dimensional | one sample from first, middle & last drawn wire coil from each wire rod | IS 398-P-2 & 5 and SAPDC Spec. | As per Approved Technical specification | MFOR | A | J | S | W | - | N | |
| 3.2 | Breaking Load/ Tensile strength | Mechanical | one sample from first, middle & last drawn wire coil from each wire rod | IS 398-P-2 & 5 and SAPDC Spec. | As per Approved Technical specification | MFOR | A | J | S | W | - | N | |
| 3.3 | Resistance | Electrical | one sample from first, middle & last drawn wire coil from each wire rod | IS 398-P-2 & 5 and SAPDC Spec. | As per Approved Technical specification | MFOR | A | J | S | W | - | N | |
| 3.4 | Wrapping Test | Mechanical | one sample from first, middle & last drawn wire coil from each wire rod | IS 398-P-2 & 5 and SAPDC Spec. | Wrap-8,unwrap-6 & wrap-6 turns on the wire itself. The wire shall not break. | MFOR | A | J | S | W | - | N | |
| 4.0 | Steel Stranding Process | | | | | | | | | | | | |
| 4.1 | Lay Ratio/ Direction & Compactness | Measurement and Visual | At the beginning of Each set up | IS 398-P-2 & 5 and SAPDC Spec. | As per Approved Technical specification | MFOR | A | J | S | W | - | N | |
| 4.2 | Pre-forming and post forming of Steel core | Visual | One sample from each length | IS 398-P-2 & 5 and SAPDC Spec. | No Spreading of strands when composite core wire is | MFOR | A | J | S | W | - | N | |
| 4.3 | Check for Joints | Visual | 100 % on each drum | IS 398-P-2 & 5 and SAPDC Spec. | There shall be NO JOINT | MFOR | A | J | S | W | - | N | |
| 4.4 | Surface smoothness | Visual | 100 % on each drum | IS 398-P-2 & 5 and SAPDC Spec. | The wire shall be free from defects | MFOR | A | J | S | W | - | N | |



| STANDARD MANUFACTURING QUALITY PLAN (SMQP) FOR MULTISTRAND ACSR & AAC CONDUCTOR C/QA/SMQP/ACSR/AAC-Rev 00 | | | | | | | | | | | | | |
|--|--|---------------|---------------------------------------|--------------------------------|---|------------------|------------------|---|---|---|---|---|---------|
| Sr. No. | Components/ Operations & Description of Test | Type of Check | Quantum of Check/ Sampling with basis | Reference document for Testing | Acceptance Norms | Format of Record | Applicable Codes | | | | | | Remarks |
| | | | | | | | 1 | 2 | 3 | 4 | 5 | 6 | |
| 5.0 | Final Conductor Stranding Process | | | | | | | | | | | | |
| 5.1 | Lay Ratio/ Direction & Compactness | Physical | At the beginning of Each set up | IS 398-P-2 & 5 and SAPDC Spec. | As per Approved Technical specification | MFOR | A | J | S | W | - | Y | |
| 5.2 | Check for Joints | Visual | 100 % on each drum | IS 398-P-2 & 5 and SAPDC Spec. | There shall be NO JOINT in the outermost layer. Joints are allowed in inner layers but no two such joints shall be less than 15 meters apart in completed conductor. | MFOR | A | J | S | W | - | N | |
| 5.3 | Surface smoothness of Strands and stranded conductor | Visual | 100% | IS 398-P-2 & 5 and SAPDC Spec. | The finished conductor shall be smooth, compact, uniform and free from all imperfections including kinks (protrusion of wires), wires cross over, over riding, looseness (wire being dislocated by finger/hand pressure and or unusual bangle noise on tapping), material inclusions, white rust, powder formation or black spot, dirt, grit etc. | MFOR | A | J | S | W | - | N | |



| STANDARD MANUFACTURING QUALITY PLAN (SMQP) FOR MULTISTRAND ACSR & AAC CONDUCTOR C/QA/SMQP/ACSR/AAC-Rev 00 | | | | | | | | | | | | | |
|--|--|---------------|--|--------------------------------|---|------------------------|------------------|---|---|---|---|---|---------|
| Sr. No. | Components/ Operations & Description of Test | Type of Check | Quantum of Check/ Sampling with basis | Reference document for Testing | Acceptance Norms | Format of Record | Applicable Codes | | | | | | Remarks |
| | | | | | | | 1 | 2 | 3 | 4 | 5 | 6 | |
| 5.4 | Conductor Packing (in process) | Visual | 100% | IS 398-P-2 & 5 and SAPDC Spec. | Medium grade Kraft/crepe paper shall be used in between the layers of conductor. After reeling the conductor, the exposed surface of the outermost layer of conductor shall be wrapped with water proof thick bituminized | MFOR | A | J | S | W | - | N | |
| C. Section: FINAL TESTING | | | | | | | | | | | | | |
| 6.0 | Routine Test on Finished Conductor | | | | | | | | | | | | |
| 6.1. | All acceptance tests | - | 20 % of the drums | IS 398-P-2 & 5 and SAPDC Spec. | Shall pass all the requirements. | MFOR | A | J | S | Z | - | N | |
| 6.2 | Check for Joints, Surface condition of strands and stranded conductor. | - | 100 % on each drum | IS 398-P-2 & 5 and SAPDC Spec. | Shall pass all the requirements. | MFOR | A | J | S | Z | - | Y | |
| 7.0 | Acceptance Tests on Finished Conductor. | | | | | | | | | | | | |
| 7.1 | Lay Ratio / Direction & Compactness | Physical | One sample from every 10 Drums or part thereof | IS 398-P-2 & 5 and SAPDC Spec. | As per Approved Technical specification | Inspection test report | A | J | U | Y | - | Y | CIP |



| STANDARD MANUFACTURING QUALITY PLAN (SMQP) FOR MULTISTRAND ACSR & AAC CONDUCTOR C/QA/SMQP/ACSR/AAC-Rev 00 | | | | | | | | | | | | | |
|--|--|---------------|--|---------------------------------------|--|------------------------|------------------|---|---|---|---|---|---------|
| Sr. No. | Components/ Operations & Description of Test | Type of Check | Quantum of Check/ Sampling with basis | Reference document for Testing | Acceptance Norms | Format of Record | Applicable Codes | | | | | | Remarks |
| | | | | | | | 1 | 2 | 3 | 4 | 5 | 6 | |
| 7.2 Acceptance Tests on Aluminum Strands of Finished Conductor. | | | | | | | | | | | | | |
| 7.2.1 | Diameter of Aluminium strands | Dimensional | One sample from every 10 Drums or part thereof | IS 398-P-2 & 5 and SAPDC Spec. | As per Approved Technical specification | Inspection test report | A | J | U | Y | - | Y | CIP |
| 7.2.2 | Breaking Load/ Tensile strength | Mechanical | One sample from every 10 Drums or part thereof | IS 398-P-2 & 5 and SAPDC Spec. | As per Approved Technical specification | Inspection test report | A | J | U | Y | - | Y | CIP |
| 7.2.3 | Resistance | Electrical | One sample from every 10 Drums or part thereof | IS 398-P-2 & 5 and SAPDC Spec. | As per Approved Technical specification | Inspection test report | A | J | U | Y | - | Y | CIP |
| 7.2.4 | Wrapping Test | Mechanical | One sample from every 10 Drums or part thereof | IS 398-P-2 & 5 and SAPDC Spec. | As per Approved Technical specification/relevant standard | Inspection test report | A | J | U | Y | - | Y | CIP |
| 7.2.5 | UTS test on welded joints of Aluminium strands by cold pressure butt welding machine | Mechanical | 5 specimen against each lot | IS 398-P-2 & 5 and SAPDC Spec. | The minimum breaking load shall be not less than the specified value in Data Sheet | Inspection test report | A | J | U | Y | - | Y | CIP |
| 7.3 Acceptance Tests on Galvanised Steel strands of Finished Conductor | | | | | | | | | | | | | |
| 7.3.1 | Diameter | Dimensional | One sample from every 10 Drums or part thereof | IS 398-P-2 ,5 IEC-888 and SAPDC Spec. | As per Approved Technical specification | Inspection test report | A | J | U | Y | - | Y | CIP |
| 7.3.2 | Tensile Strength/ Breaking Load | Mechanical | One sample from every 10 Drums or part thereof | IS 398-P-2 ,5 IEC-888 and SAPDC Spec. | As per Approved Technical specification | Inspection test report | A | J | U | Y | - | Y | CIP |
| 7.3.3 | Elongation at break | Mechanical | One sample from every 10 Drums or part thereof | IS 398-P-2 ,5 IEC-888 and SAPDC Spec. | As per Approved Technical specification | Inspection test report | A | J | U | Y | - | Y | CIP |
| 7.3.4 | Torsion Test | Mechanical | One sample from every 10 Drums or part thereof | IS 398-P-2 ,5 IEC-888 and SAPDC Spec. | As per Approved Technical specification | Inspection test report | A | J | U | Y | - | Y | CIP |
| 7.3.5 | Wrapping Test | Mechanical | One sample from every 10 Drums or part thereof | IS 398-P-2 ,5 IEC-888 and SAPDC Spec. | Wrap-8,unwrap-6 & wrap-6 On a mandrel having diameter equal to 4 x diameter of wire. The wire shall not break. | Inspection test report | A | J | U | Y | - | Y | CIP |



| STANDARD MANUFACTURING QUALITY PLAN (SMQP) FOR MULTISTRAND ACSR & AAC CONDUCTOR C/QA/SMQP/ACSR/AAC-Rev 00 | | | | | | | | | | | | | |
|--|--|----------------------|--|--|--|------------------------|------------------|---|---|---|---|---|---------|
| Sr. No. | Components/ Operations & Description of Test | Type of Check | Quantum of Check/ Sampling with basis | Reference document for Testing | Acceptance Norms | Format of Record | Applicable Codes | | | | | | Remarks |
| | | | | | | | 1 | 2 | 3 | 4 | 5 | 6 | |
| 7.3.6 | Adhesion Test | Mechanical | One sample from every 10 Drums or part thereof | IS 398-P-2 ,5 IEC-888 and SAPDC Spec. | The Zinc coating shall remain adherent to the steel wire when wound 10 turns on a mandrel having dia. 4x dia. of wire | Inspection test report | A | J | U | Y | - | Y | CIP |
| 7.3.7 | Preece Test (Dip Test) | Chemical | One sample from every 10 Drums or part thereof | IS 398-P-2 ,5 IS 4826, IEC 888 and SAPDC Spec. | As per Approved Technical specification | Inspection test report | A | J | U | Y | - | Y | CIP |
| 7.3.8 | Mass of Zinc coating | Chemical | One sample from every 10 Drums or part thereof | IS 398-P-2 ,5 IS 4826, IEC 888 and SAPDC Spec. | As per Approved Technical specification | Inspection test report | A | J | U | Y | - | Y | CIP |
| 7.4 | Length measurement of Finished Conductor | | | | | | | | | | | | |
| 7.4.1 | Check for joints, surface finish and length measurement by rewinding | Visual & Measurement | One sample from every 10 Drums or part thereof | IS 398-P-2 & 5 and SAPDC Spec. | No scale on the surface and the surface shall be free from any imperfections. No joint on the outermost layer. The conductor length should be as per the offered packing list & drums as per approved drawing. | Inspection test report | A | J | U | Y | - | Y | CIP |
| 8.0 | Wooden Drums and packing materials | | | | | | | | | | | | |
| 8.1 | Dimensional check of wooden drums | Dimensional | 10% of offered drums | IS 1778 and SAPDC approved Drum drawing | SAPDC approved drum drawing | Inspection test report | A | J | U | Y | - | Y | CIP |



| STANDARD MANUFACTURING QUALITY PLAN (SMQP) FOR MULTISTRAND ACSR & AAC CONDUCTOR C/QA/SMQP/ACSR/AAC-Rev 00 | | | | | | | | | | | | | |
|--|--|---------------|--|---|---|------------------------|------------------|---|------|---|---|---|---|
| Sr. No. | Components/ Operations & Description of Test | Type of Check | Quantum of Check/ Sampling with basis | Reference document for Testing | Acceptance Norms | Format of Record | Applicable Codes | | | | | | Remarks |
| | | | | | | | 1 | 2 | 3 | 4 | 5 | 6 | |
| 8.2 | Barrel Batten Test | Mechanical | One sample from every 10 Drums or part thereof | IS 1778 | Barrel Baten strength Min. 300 Kgf | Inspection test report | A | J | U | Y | - | Y | CIP |
| 8.3 | Chemical Test on water proof bituminised bamboo paper | Chemical | One sample per batch of paper | - | Chloride - 0.05 % max., Sulphate- 0.25 % max., Copper - 0.01 % Max., pH- 5.5 to 7.5 | TPL report | D | L | V | Y | - | N | |
| 8.4 | Visual check of wooden drums | Visual | 100% drums | IS 1778 and SAPDC approved Drum drawing | The inner check of the flanges & drum barrels surface shall be painted with bitumin based paint. Before relling cardboard or double conugatd or thick bituminized water proof bamboo paper shall be secured to the drum barrel and inside of the flanges of drum. | Inspn. Report | A | J | U | Y | - | Y | CIP |
| 9.0 | Packing, Marking and Dispatch | | | | | | | | | | | | |
| 9.1 | Application of bituminised bamboo paper | Visual | 100% | SAPDC Spec.. | SAPDC specs. | Joint Inspn. Report | A | J | S/U* | Y | - | N | |
| 9.2 | Distance between outermost layer and inner surface of protective | Visual | 100% | SAPDC Spec.. | SAPDC Spec. (Min 75 mm) | Packing List | A | J | S/U* | Y | - | N | |
| 9.3 | Number of turns in outer most layer | Visual | 100% | SAPDC Spec.. | SAPDC specs. | Packing List | A | J | S/U* | Y | - | N | |
| 9.4 | Contract/ Award Letter no. | Visual | 100% | SAPDC Spec.. | SAPDC Spec. | Packing List | A | J | S/U* | Y | - | N | *100 % by Conductor manufacturer & 10 % by SAPDC. |
| 9.5 | Manufacturer's Name and Address | Visual | 100% | SAPDC Spec.. | SAPDC Spec.. | Packing List | A | J | S/U* | Y | - | N | |
| 9.6 | Drum No. | Visual | 100% | SAPDC Spec.. | SAPDC Spec.. | Packing List | A | J | S/U* | Y | - | N | |
| 9.7 | Size and Code Name of Conductor | Visual | 100% | SAPDC Spec.. | SAPDC Spec.. | Packing List | A | J | S/U* | Y | - | N | |



| STANDARD MANUFACTURING QUALITY PLAN (SMQP) FOR MULTISTRAND ACSR & AAC CONDUCTOR C/QA/SMQP/ACSR/AAC-Rev 00 | | | | | | | | | | | | | |
|--|---|---------------|---------------------------------------|--------------------------------|------------------|------------------|------------------|---|------|---|---|---|--|
| Sr. No. | Components/ Operations & Description of Test | Type of Check | Quantum of Check/ Sampling with basis | Reference document for Testing | Acceptance Norms | Format of Record | Applicable Codes | | | | | | Remarks |
| | | | | | | | 1 | 2 | 3 | 4 | 5 | 6 | |
| 9.8 | Length of Conductor | Visual | 100% | SAPDC Spec.. | SAPDC Spec.. | Packing List | A | J | S/U* | Y | - | N | |
| 9.9 | Gross weight of the drum after lagging | Visual | 100% | SAPDC Spec.. | SAPDC Spec.. | Packing List | A | J | S/U* | Y | - | N | |
| 9.10 | Tare weight with lagging | Visual | 100% | SAPDC Spec.. | SAPDC Spec.. | Packing List | A | J | S/U* | Y | - | N | |
| 9.11 | Net weight of the conductor in the Drum | Visual | 100% | SAPDC Spec.. | SAPDC Spec.. | Packing List | A | J | S/U* | Y | - | N | |
| 9.12 | Arrow marking for rolling the conductor drum | Visual | 100% | SAPDC Spec.. | SAPDC Spec.. | Packing List | A | J | S/U* | Y | - | N | |
| 9.13 | Sealing of Drums 100% as per SAPDC approved sealing procedure | Visual | 100% | SAPDC Spec.. | SAPDC Spec.. | | A | J | U | Y | - | Y | CIP 100% by SAPDC |
| 9.14 | Tack welding on Nuts on the barrel and Hub Plates. | Visual | 100% | SAPDC Spec.. | SAPDC Spec.. | | A | J | S/U* | W | - | N | |
| 9.15 | Name of Address of Consignee | Visual | 100% | SAPDC Spec.. | SAPDC Spec.. | | A | J | S/U* | W | - | N | *100 % by Conductor manufacturer & 10 % by SAPDC |

Volume-III

**Bid Form, Price Schedules & Technical Data
Sheets**

| Section | Description |
|---|--|
| Volume-III : Bid Form, Price Schedules & Technical Data Sheets | |
| Section-I | Bid Form & Technical Data Sheets Under Envelope-I i.e along with Techno-commercial bid |
| Section-II | Bid Form & Price Schedules Under Envelope-II along with Price bid |



| Section | Description |
|---|--|
| Volume-III : Bid Form, Price Schedules & Technical Data Sheets | |
| Section-I | Bid Form & Technical Data Sheets Under Envelope-I i.e along with Techno-commercial bid |

Submission: Hard copy of Dully filled, Signed & stamped of bid form & technical data sheets to be submitted along with Technical bid i.e in ENVELOPE-I as per bidding condition and Soft copy/Scanned copy of same shall also to be uploaded/submitted on SJVN e-portal.





| | | |
|---|---|---|
| SJVN Arun-3 Power Development Company Pvt. Ltd. | |  |
| Dully filled, signed and stamped Attachments to be submitted along with Technical bid i.e in Envelope-I | | |
| Conductor Package- CD03 for supply of ACSR MOOSE Conductor for part of Diding – Dhalkebar – Bathnaha Transmission Line corresponding to Tower Package-TW01 associated with Arun-3 HEP in Nepal under Consultancy services to SAPDC. | | |
| <u>Specification No.: SAPDC/P&C/Arun-3HEP/CD03/2023 (CD03)</u> | | |
| 1 | Fill, Signed & stamped the relevant attachments. | |
| 2 | Attachments 3(JV), 3(QR), Attach QR, 4, 4(A), 4(B), 5, 6, 7, 9, 10, 11, 12, 13, 14, 15, 16, 17,18, 19, 21 and Bid Form for Envelope-I are included here. | |
| 3 | Attachment 1 Bid Security: To be submitted as per proforma provided in the bidding document. | |
| 4 | Attachment 2 Power of Attorney: No specific format is provided by SAPDC. Bidder may use their own format. | |
| 5 | Attachment 8 Manufacturer’s Authorization Form: To be furnished as per proforma provided in the bidding document, on the letter head of the each Manufactures proposed to supply main items. Not included here. | |
| 6 | Attachment 14 Integrity Pact(Schedule-F): To be submitted as per ITB Clause | |
| 7 | Attachment 18: Declaration | |
| 8 | Attachment-19: Declaration of Key Managerial Person and Power of Attorney holder | |
| 9 | Attachment-21: Compliance to the process related to the e-RA Terms & Conditions and the Business Rules governing the e-RA | |



| | |
|---|--|
| Conductor Package (CD03) for Supply of ACSR MOOSE Conductor for part of Diding – Dhalkebar – Bathnaha Transmission Line corresponding to Tower Package- TW02; associated with Arun-3 HEP in Nepal. | |
| Specification No.: SAPDC/P&C/Arun-3HEP/CD03/2023 (CD03) | |
| Enter following details of the bidder | |
| Specify type of Bidder | |
| Name of Qualified Licensee | |
| Address of Qualified Licensee | |
| Name of Qualified Manufacturer (the Licenser) | |
| Address of Licenser | |
| Name | |
| Designation | |
| Date: | |
| Place: | |

For and on behalf of the bidder /Supplier

.....

(Name, Designation & Signature of authorized representative of the Bidder/Supplier, along with his name, Seal of Company)



| | |
|---|-------------------------|
| Specification No.: SAPDC/P&C/Arun-3HEP/CD03/2023 (CD03) | Attachment-3(JV) (CD03) |
| Conductor Package(CD03) for Supply of ACSR MOOSE Conductor for part of Diding – Dhalkebar – Bathnaha Transmission Line corresponding to Tower Package- TW02; associated with Arun-3 HEP in Nepal. | |
| (Joint Venture Agreement and Power of Attorney for Joint Venture*) | |
| Bidder's Name and Address (Qualified Licensee): | To: |
|  NOT APPLICABLE | |

For and on behalf of the bidder /Supplier

.....

(Name, Designation & Signature of authorized representative of the Bidder/Supplier, along with his name, Seal of Company)



| | | | |
|---|--|---|--|
| Specification No.: SAPDC/P&C/Arun-3HEP/CD03/2023 (CD03) | | Attachment-3(QR) (CD03) | |
| Conductor Package(CD03) for Supply of ACSR MOOSE Conductor for part of Diding – Dhalkebar – Bathnaha Transmission Line corresponding to Tower Package- TW02; associated with Arun-3 HEP in Nepal. | | | |
| (Qualifying Requirement Data) (As applicable) | | | |
| Bidder's Name and Address (Qualified Licensee): | | To: | |
| Name : | | To: | |
| Address : | | O/o Chief Engineer (P&C), SAPDC, Arun-3 HEP, Satluj Bhawan, Arun Sadan, Tumlingtar, Distt. Sankhuwasabha, Nepal Ph. +977-29-575154, Mob.: +977-9852099789/+91- 9816072198. | |
| Dear Sir, | | | |
| For our Qualifying Requirements Data, please refer Schedule-QR of this volume. | | | |
| Date : | | Name: | |
| Place : | | Designation: | |

For and on behalf of the bidder /Supplier

.....

(Name, Designation & Signature of authorized representative of the Bidder/Supplier, along with his name, Seal of Company)



| | | |
|---|--|--|
| Specification No.: SAPDC/P&C/Arun-3HEP/CD03/2023 (CD03) | | Schedule-QR (CD03) |
| Conductor Package (CD03) for Supply of ACSR MOOSE Conductor for part of Diding – Dhalkebar – Bathnaha Transmission Line corresponding to Tower Package- TW02; associated with Arun-3 HEP in Nepal. | | |
| (Qualifying Requirement Data) (As applicable) | | |
| Bidder's Name and Address (Qualified Licensee) : | | To: |
| Name: | | To: |
| Address: | | O/o Chief Engineer (P&C), SAPDC, Arun-3 HEP, Satluj Bhawan, Arun Sadan, Tumlingtar, Distt. Sankhuwasabha, Nepal Ph. +977- 29-575154, Mob.: +977- 9852099789/+91-9816072198. |
| Dear Sir, | | |
| In support of the Qualification Requirements (QR) for bidders, stipulated in Annexure-A (BDS) of the Section - III (BDS), Volume-I & additional information required as per ITB clause 9.3(c) of the Bidding Documents, we furnish herewith our QR data/details/documents etc., alongwith other information, as follows (The QR stipulations have been reproduced in italics for ready reference, however, in case of any discrepancy, the QR as given in BDS shall prevail). | | |
| We have submitted bid as Qualified Licensee of Qualified Manufacturer: | | |
| We are furnishing the following details/document in support of Qualifying requirement for the subject package. | | |
| A | Attached copies of original documents of Sole Bidder/ all Partner of the JV (if applicable) | |
| a) | The constitution or legal status; | |
| b) | The principal place of business; | |
| c) | The place of incorporation (for bidders who are corporations); or the place of registration and the nationality of the Owners (for applicants who are partnerships or individually-owned firms). | |
| B | Attached original & copies of the following documents. | |
| a) | Written power of attorney of the signatory of the Bid to commit the bidder. | |
| b) | Joint Undertaking by the Licensor along with the Licensee. (if applicable) | |
| 1.0 | GENERAL INFORMATION | |
| | Bidder is required to provide general information as per the following format. | |



| | | |
|------------|---|--|
| | [Where the Bidder proposes to use named subcontractor(s) for critical components of the works or for work contents in excess of ten (10) percent of the bid price, the following information should also be supplied for the subcontractor(s)]. | |
| S No. | Particulars | For a Qualified Licensee of Qualified Manufacturer |
| 1 | Name of the Firm | |
| 2 | Head Office/ Registered Office Address | |
| 3 | Telephone | |
| 4 | Fax | |
| 5 | Contact Person | |
| 6 | Place of Incorporation/ Registration | |
| 7 | Year of Incorporation/ Registration | |
| 8 | Nationality of | |
| | Owner (i) | |
| | Owner (ii) | |
| | Owner (iii) | |
| 2.0 | TECHNICAL REQUIREMENTS | |
| 2.1 | Technical Experience | |
| 2.1.1 | <i>{Reference para 1.1 of Annexure-A (BDS)}</i> | |
| | <i>The bidder's experience should include the following:</i> | |



| | | | | | | | | | | | |
|---|---|----|---|----|--|----|---|----|---|----|---|
| (a) | <p><i>The bidder shall be a manufacturer of Conductor. The bidder's experience should include the following:</i></p> <p><i>(i) The bidder should have manufactured, tested and supplied at least one thousand (1000) Kms of Sixty one (61) or above strands of ACSR/AAAC conductor during last Seven (7) years as originally schedule date of bid opening i.e. 01.03.2023</i></p> | | | | | | | | | | |
| (b) | <p><i>However, if the bidder is not meeting the above requirements of its own, he should be a qualified Licensee of a qualified manufacturer meeting the above specified requirements and should also meet the following conditions:</i></p> <p><i>(i) Manufacturer/Licensee shall have adequate design infrastructure and manufacturing facility and capacity and procedures including quality control.</i></p> <p><i>(ii) A qualified Licensee of a qualified manufacturer shall comply with all of the following requirements and furnish a joint undertaking by the licensor along with the bidder in its bid as per proforma enclosed in Section 'FORMS' of Conditions of Contract, Vol-I:</i></p> <table border="1" data-bbox="304 994 1407 1581"> <tr> <td data-bbox="304 994 379 1070">a.</td> <td data-bbox="379 994 1407 1070"><i>Any design undertaken by the Licensee shall be approved by the Licensor.</i></td> </tr> <tr> <td data-bbox="304 1070 379 1193">b.</td> <td data-bbox="379 1070 1407 1193"><i>Manufacturing by the Licensee shall be done with the approval of the Licensor and Purchaser under a quality assurance programme approved and monitored by the Licensor.</i></td> </tr> <tr> <td data-bbox="304 1193 379 1317">c.</td> <td data-bbox="379 1193 1407 1317"><i>Licensee must furnish back-up guarantee from the licensor for individual and overall performance of all materials supplied under the contract.</i></td> </tr> <tr> <td data-bbox="304 1317 379 1440">d.</td> <td data-bbox="379 1317 1407 1440"><i>Licensor must guarantee sequential and timely supply of materials and submission of technical information and data as desired by the Purchaser so as to meet the overall construction schedule and</i></td> </tr> <tr> <td data-bbox="304 1440 379 1581">e.</td> <td data-bbox="379 1440 1407 1581"><i>The agreement between Licensee and Licensor (copy to be submitted along with the bid) shall be valid for a period of at least five (5) years after the guarantee period of equipment and materials under supply is over.</i></td> </tr> </table> | a. | <i>Any design undertaken by the Licensee shall be approved by the Licensor.</i> | b. | <i>Manufacturing by the Licensee shall be done with the approval of the Licensor and Purchaser under a quality assurance programme approved and monitored by the Licensor.</i> | c. | <i>Licensee must furnish back-up guarantee from the licensor for individual and overall performance of all materials supplied under the contract.</i> | d. | <i>Licensor must guarantee sequential and timely supply of materials and submission of technical information and data as desired by the Purchaser so as to meet the overall construction schedule and</i> | e. | <i>The agreement between Licensee and Licensor (copy to be submitted along with the bid) shall be valid for a period of at least five (5) years after the guarantee period of equipment and materials under supply is over.</i> |
| a. | <i>Any design undertaken by the Licensee shall be approved by the Licensor.</i> | | | | | | | | | | |
| b. | <i>Manufacturing by the Licensee shall be done with the approval of the Licensor and Purchaser under a quality assurance programme approved and monitored by the Licensor.</i> | | | | | | | | | | |
| c. | <i>Licensee must furnish back-up guarantee from the licensor for individual and overall performance of all materials supplied under the contract.</i> | | | | | | | | | | |
| d. | <i>Licensor must guarantee sequential and timely supply of materials and submission of technical information and data as desired by the Purchaser so as to meet the overall construction schedule and</i> | | | | | | | | | | |
| e. | <i>The agreement between Licensee and Licensor (copy to be submitted along with the bid) shall be valid for a period of at least five (5) years after the guarantee period of equipment and materials under supply is over.</i> | | | | | | | | | | |
| <p><i>In case bidder is a holding company, the technical experience referred to in clause 2.1 above shall be of that holding company only (i.e. excluding its subsidiary/group companies). In case bidder is a subsidiary of a holding company, the technical experience referred to in clause 2.1 above shall be of that subsidiary company only (i.e. excluding its holding companies).</i></p> | | | | | | | | | | | |
| 2.1.2 | <p>Using the following format, each Bidder is requested to list the contracts of a nature similar to the proposed contract(s) for which the Bidder wishes to qualify, undertaken during the last seven (7) years. The information is to be summarised for each such contract separately.</p> | | | | | | | | | | |



| | (The bidder shall attach documentary evidence, such as copies of utility/Completion certificates etc., in support of its general experience as listed in the following proforma for each experience/ Contract | | | | | | | | | | | | | | | | | |
|---------------|---|---|------|--|------|--|---------------|--|---------------|--|---------|--|---------|--|--------|--|--------|--|
| | <u>Format A: Format for the bidders (manufacturers) who wish to qualify through route 2.1(a) :</u> | | | | | | | | | | | | | | | | | |
| a | No. of years the bidder is a manufacturer of Conductor of similar nature [Last _____ years.] | | | | | | | | | | | | | | | | | |
| b | Name of Contract | | | | | | | | | | | | | | | | | |
| c | Contract Reference No. & Date of Award | | | | | | | | | | | | | | | | | |
| d | Name and Address of the Purchaser/Utility for whom the Contract was executed by the Bidder/Partner | | | | | | | | | | | | | | | | | |
| | E-mail ID | | | | | | | | | | | | | | | | | |
| | Telephone No. | | | | | | | | | | | | | | | | | |
| | Fax No. | | | | | | | | | | | | | | | | | |
| e | Scope of work involved in the supply of Sixty One (61) or above strands ACSR/AAAC Conductor under the above Contract(Tick only whichever is/are applicable) | <table border="1"> <thead> <tr> <th>ACSR</th> <th></th> <th>AAAC</th> <th></th> </tr> </thead> <tbody> <tr> <td>Manufacturing</td> <td></td> <td>Manufacturing</td> <td></td> </tr> <tr> <td>Testing</td> <td></td> <td>Testing</td> <td></td> </tr> <tr> <td>Supply</td> <td></td> <td>Supply</td> <td></td> </tr> </tbody> </table> | ACSR | | AAAC | | Manufacturing | | Manufacturing | | Testing | | Testing | | Supply | | Supply | |
| ACSR | | AAAC | | | | | | | | | | | | | | | | |
| Manufacturing | | Manufacturing | | | | | | | | | | | | | | | | |
| Testing | | Testing | | | | | | | | | | | | | | | | |
| Supply | | Supply | | | | | | | | | | | | | | | | |
| f | Details/features of the Contract undertaken relevant to the stipulated QR (as in Sl No (a.) of 2.1.1) | | | | | | | | | | | | | | | | | |
| | i) Total no. of Kms. of Sixty One (61) or above strands ACSR/AAAC Conductor supplied in the above Contract | (In kms.) | | | | | | | | | | | | | | | | |



| | | | |
|--|--|------------------------------|-----------------------------|
| | ii) No. of strands supplied in the Contract detailed above | (In Nos.) | |
| g | Date of Completion of Contract | | |
| h | Details of documents submitted in support of stated experience/Contract/ design, infrastructure and manufacturing facilities and capacity and procedures including quality control | | |
| <u>Format B: Format for the bidders who wish to qualify through route 2.1(b):</u> | | | |
| | Name of Licensee of a qualified manufacturer | | |
| | Name of qualified manufacturer | | |
| | Whether the Qualified Manufacturer (i.e. Licensor) meets the requirements as specified at 2.1(a) above <i>If Yes, fill the requisite details in Format A above.</i> | <input type="checkbox"/> Yes | <input type="checkbox"/> No |
| | Whether the Manufacturer/Licensee has adequate design infrastructure and manufacturing facility and capacity and procedures including quality control. | <input type="checkbox"/> Yes | <input type="checkbox"/> No |
| | Whether Licensee of a qualified manufacturer complies with all of the following requirements: | | |
| | a) Whether any design undertaken by the Licensee shall be approved by the Licensor. | <input type="checkbox"/> Yes | <input type="checkbox"/> No |



| | | |
|-------------------|--|---|
| | <p>b) Whether Manufacturing by the Licensee shall be done with the approval of the Licensor and Purchaser under a quality assurance programme approved and monitored by the Licensor.</p> | <p><input type="checkbox"/> Yes <input type="checkbox"/> No</p> |
| | <p>c) Whether Licensee will furnish back-up guarantee from the licensor for individual and overall performance of all materials supplied under the contract.</p> | <p><input type="checkbox"/> Yes <input type="checkbox"/> No</p> |
| | <p>d) Whether Licensor guarantees sequential and timely supply of materials and submission of technical information and data as desired by the Purchaser so as to meet the overall construction schedule and</p> | <p><input type="checkbox"/> Yes <input type="checkbox"/> No</p> |
| | <p>e) Whether copy of agreement between Licensee and Licensor is submitted along with the bid</p> | <p><input type="checkbox"/> Yes <input type="checkbox"/> No</p> |
| | <p>f) No. of years, after the guarantee period of equipment and materials under supply is over, the agreement between Licensee and Licensor is valid.</p> | <p><input type="text"/></p> |
| | <p>g) Whether Joint Undertaking by the Licensor along with the Licensee (bidder) is submitted along with the bid</p> | <p><input type="checkbox"/> Yes <input type="checkbox"/> No</p> |
| | <p>Details of documents submitted in support of stated experience / Contract / design, infrastructure and manufacturing facilities and capacity and procedures including quality control</p> | <p><input type="text"/></p> |
| <p>3.0</p> | <p>Financial requirement</p> | |
| <p>3.1</p> | <p>{Reference para 1.2 of Annexure-A (BDS)}</p> | |
| | <p><i>For the purpose of this particular bid, bidders shall meet the following minimum criteria</i></p> | |



| | | | | |
|----------|--|--|--|--|
| a) | <i>Net worth for last 3 financial years should be positive.</i> | | | |
| b) | <i>Minimum Average Annual Turnover* (MAAT) for best three years i.e. 36 months out of last five financial years of the bidder should be:</i> | | | |
| | i. Indian Rs. 76.00 Crore for Package-CD03 | | | |
| | <i>* Note: Annual Gross Revenue from operations/Gross operating income as incorporated in the profit & loss account excluding Other Income.</i> | | | |
| c) | <i>Bidder shall have liquid assets (L.A) or/and evidence of access to or availability of credit facilities of not less than:</i> | | | |
| | i. Indian Rs. 40.00 Crore for Package-CD03 | | | |
| | <i>In case bidder is a holding company, the financial position criteria referred to in clause 3.1 above shall be of that holding company only (i.e excluding its subsidiary/ group companies). In case bidder is a subsidiary of a holding company, the financial position criteria referred to in clause 3.1 above shall be of that subsidiary company only (i.e excluding its holding company).</i> | | | |
| d) | <i>In case of a bid submitted by a qualified Licensee of a qualified manufacturer, the requirements stipulated at Clause 3.1 above shall be individually met by the Licensee as well as the Licensor.</i> | | | |
| 3.2 | In support of its 'Financial Position', in line with the above, the Bidder must provide the relevant information, alongwith documentary evidence, in the following formats A & B: | | | |
| | | For a Qualified Licensee of Qualified Manufacturer | | |
| | Name of the Bidder | | | |
| A | Average Annual Turnover details: | Average annual turnover in Rs. Million | Average annual turnover in Rs. Million | Average annual turnover in Rs. Million |
| Sl No. | Financial year | | | |
| | Do you have audited results for FY 2021-22 | <input type="checkbox"/> Yes <input type="checkbox"/> No | <input type="checkbox"/> Yes <input type="checkbox"/> No | <input type="checkbox"/> Yes <input type="checkbox"/> No |
| 1 | 2021-2022 | | | |
| 2 | 2020-2021 | | | |
| 3 | 2019-2020 | | | |
| 4 | 2018-2019 | | | |



| | | | | |
|----------|--|--|--|--|
| 5 | 2017-2018 | | | |
| 6 | 2016-2017 | | | |
| | Average Annual Turnover for best Three Years is | | | |
| B | Liquid Assets | | | |
| | Details of evidence of having Liquid assets (LA) | | | |
| | Or | | | |
| | Details of evidence of access to or availability of credit facilities | | | |
| 4.0 | <i>The Bidder shall also furnish following documents/details with its bid. {Reference ITB clause 9.3 (c)}</i> | | | |
| 4.1 | <i>The complete annual reports together with Audited statement of accounts of the company for last five years of its own (separate) immediately preceding the date of submission of bid.</i> | | | |
| | <i>No te- I.</i> | <i>In the event the bidder is not able to furnish the information of its own (i.e separate), being a subsidiary company and its accounts are being consolidated with its group/holding/parent company, the bidder should submit the audited balance sheets, income statements, other information pertaining to it only (not of its group/Holding/Parent Company) duly certified by any one of the authority [(i) Statutory Auditor of the bidder /(ii) Company Secretary of the bidder or (iii) A certified Public Accountant] certifying that such information/documents are based on the audited accounts as the case may be.</i> | | |
| | <i>II.</i> | <i>Similarly, if the bidder happens to be a Group/Holding/Parent Company, the bidder should submit the above documents/information of its own (i.e. exclusive of its subsidiaries) duly certified by any one of the authority mentioned in Note-I above certifying that these information/documents are based on the audited accounts, as the case may be.</i> | | |
| 4.2 | The Bidder should accordingly also provide the following information/documents: | | | |



| | | | | |
|------------|---|--|--|--|
| | Audited balance sheet and income statements for the last five years as per the following: | | | |
| | For a Qualified Licensee of Qualified Manufacturer | | | |
| A | Years preceding to the bid opening | Audited Balance Sheet and Income Statements enclosed | Audited Balance Sheet and Income Statements enclosed | Audited Balance Sheet and Income Statements enclosed |
| | 1st Year | | | |
| | 2nd Year | | | |
| | 3rd Year | | | |
| | 4th Year | | | |
| | 5th Year | | | |
| 5.0 | Financial Qualification Data {Reference para 1.2 (a), (b) & (c) of | | | |



| Annexure-A (BDS): | | | | | | | |
|-------------------|--|---------|---------|--------------|---------|---------|---------|
| [in INR Million] | | | | | | | |
| SN | Financial Parameters | 2021-22 | 2020-21 | 2019-20 | 2019-20 | 2018-19 | 2017-18 |
| 1 | Net Worth | | | | | | |
| a) | Paid Up Capital | | | | | | |
| b) | Free Reserves and Surplus * | | | | | | |
| c) | Misc expenses to the extent not written off | | | | | | |
| | Net Worth (a+b-c) | | | | | | |
| 2 | Annual Turnover ** | | | | | | |
| 3 | Liquid Assset (Total Current Asset - Inventories) | | | | | | |
| * | Free Reserve and Surplus should be Exclusive of Revaluation Reserve, written back of Depreciation Provision and Amalgamation. | | | | | | |
| ** | Annual Gross Revenue from operations/Gross operating income as incorporated in the profit & loss account excluding Other Income. | | | | | | |
| Date: | | | | Name: | | | |
| Place: | | | | Designation: | | | |



For and on behalf of the bidder /Supplier

.....

(Signature of authorized representative of the
Bidder/Supplier, along with his name, Seal of Company)





| | | |
|--|--|--|
| Specification No.: SAPDC/P&C/Arun-3HEP/CD03/2023 (CD03) | | Attachment-4 (CD03) |
| Conductor Package(CD03) for Supply of ACSR MOOSE Conductor for part of Diding – Dhalkebar – Bathnaha Transmission Line corresponding to Tower Package- TW02; associated with Arun-3 HEP in Nepal. | | |
| (Form of Certificate of Origin and Eligibility) | | |
| Bidder's Name and Address (Qualified Licensee): | | To: |
| Name : | | To: |
| Address : | | O/o Chief Engineer (P&C), SAPDC, Arun-3 HEP, Satluj Bhawan, Arun Sadan, Tumlingtar, Distt. Sankhuwasabha, Nepal Ph. +977-29-575154, Mob.: +977-9852099789/+91-9816072198. |

Dear Sir,

We hereby certify that equipment and materials to be supplied are produced in [Name of Countries], eligible source country.

We hereby certify that our company is incorporated and registered in [Name of Countries], eligible source country.

| | |
|--|--|
| Equipments & Materials produced in [Name of countries] | Company incorporated & registered in [Name of countries] |
| [Name of Countries] | [Name of Countries] |
| | |
| | |
| | |
| | |
| Date: | Name: |
| Place: | Designation: |

For and on behalf of the bidder /Supplier

.....

(Name, Designation & Signature of authorized representative of the Bidder/Supplier, along with his name, Seal of Company)



| | | |
|---|--|---|
| Specification No.: SAPDC/P&C/Arun-3HEP/CD03/2023 (CD03) | | Attachment-4(A) (CD03) |
| Conductor Package (CD03) for Supply of ACSR MOOSE Conductor for part of Diding – Dhalkebar – Bathnaha Transmission Line corresponding to Tower Package- TW02; associated with Arun-3 HEP in Nepal. | | |
| (List of Special Maintenance Tools & Tackles) | | |
| Bidder's Name and Address (Qualified Licensee) : | | To: |
| Name : | | To: |
| Address : | | O/o Chief Engineer (P&C), SAPDC, Arun-3 HEP, Satluj Bhawan, Arun Sadan, Tumlingtar, Distt. Sankhuwasabha, Nepal Ph. +977-29-575154, Mob.: +977- 9852099789/+91-9816072198. |

Dear Sir,

We are furnishing below the list of special maintenance tools & tackles for various equipment under the subject package. The prices for these tools & tackles are included in our lumpsum bid price. We further confirm that the list of special maintenance tools & tackles includes all the items specifically identified in your bidding documents as brought out below:

| S.No. | For Equipment | Item Description | Unit | Quantity |
|-------|---------------|------------------|------|----------|
| 1 | | | | |
| 2 | | | | |
| 3 | | | | |

Notwithstanding what is stated above, we further confirm that any additional special maintenance tools and tackles, required for the equipment under this package shall be furnished by us at no extra cost to the employer.

Date:

Name:

Place:

Designation:

For and on behalf of the bidder /Supplier

.....

(Name,

Designation & Signature of authorized representative of the Bidder/Supplier, along with his name, Seal of Company)



| | | |
|--|--|--|
| Specification No.: SAPDC/P&C/Arun-3HEP/CD03/2023 (CD03) | | Attachment-4(B) (CD03) |
| Conductor Package(CD03) for Supply of ACSR MOOSE Conductor for part of Diding – Dhalkebar – Bathnaha Transmission Line corresponding to Tower Package- TW02; associated with Arun-3 HEP in Nepal. | | |
| (List of Special Maintenance Tools & Tackles) | | |
| Bidder's Name and Address (Qualified Licensee): | | To: |
| Name : | | To: O/o Chief Engineer (P&C), SAPDC, Arun-3 HEP, Satluj Bhawan, Arun Sadan, Tumlingtar, Distt. Sankhuwasabha, Nepal Ph. +977-29-575154, Mob.: +977-9852099789/+91-9816072198. |
| Address : | | |

Dear Sir,

We are furnishing below the list of special maintenance tools & tackles for various equipment under the subject package. The prices for these tools & tackles which are to be taken back after the completion of the work by us are not included in our lumpsum bid price. We further confirm that the list of special maintenance tools & tackles includes all the items specifically identified in your bidding documents as brought out below:

| | |
|-----|--|
| (a) | |
| (b) | |
| (c) | |

Date :

Name :

Place :

Designation :

For and on behalf of the bidder /Supplier

.....

(Signature of authorized representative of the Bidder/Supplier, along with his name, Seal of Company)



| | | | |
|---|--|--|--|
| Specification No.: SAPDC/P&C/Arun-3HEP/CD03/2023 (CD03) | | Attachment-5 (CD03) | |
| Conductor Package (CD03) for Supply of ACSR MOOSE Conductor for part of Diding – Dhalkebar – Bathnaha Transmission Line corresponding to Tower Package- TW02; associated with Arun-3 HEP in Nepal. | | | |
| (Subcontractors Proposed by the Bidders) | | | |
| Bidder's Name and Address (Qualified Licensee) : | | To: | |
| Name : | | To: | |
| Address : | | O/o Chief Engineer (P&C), SAPDC, Arun-3 HEP, Satluj Bhawan, Arun Sadan, Tumlingtar, Distt. Sankhuwasabha, Nepal Ph. +977-29-575154, Mob.: +977-9852099789/+91-9816072198. | |

Dear Sir,

We hereby furnish the details of the items/ sub-assemblies, we propose to buy for the purpose of furnishing and installation of the subject Package:

| Sl. No. | Item Description | Quantity proposed to be bought/sub-contracted | Details of the proposed sub-contractor/sub-vendor | |
|---------|------------------|---|---|-------------|
| | | | Name | Nationality |
| 1 | | | | |
| 2 | | | | |
| 3 | | | | |
| 4 | | | | |
| 5 | | | | |

We hereby declare that, we would not subcontract the erection portion of the contract without the prior approval of Employer.



We hereby furnish the details of the items/ sub-assemblies propose to supply from our own works (i.e. as direct transactions) in additional to the supplies the same from other vendors (i.e. as Bought-out transactions) as detailed in the table given above.

| Sl. No. | Item Description | Quantity proposed to be supplied | Details of the plant from where supplies are proposed. | |
|---------|------------------|----------------------------------|--|---------|
| | | | Name of Plant | Address |
| 1 | | | | |
| 2 | | | | |
| 3 | | | | |

Date :

Name :

Place :

Designation :



For and on behalf of the bidder /Supplier

.....

(Name, Designation & Signature of authorized representative of the Bidder/Supplier, along with his name, Seal of Company)



| | | |
|---|--|--|
| Specification No.: SAPDC/P&C/Arun-3HEP/CD03/2023 (CD03) | | Attachment-6 (CD03) |
| Conductor Package (CD03) for Supply of ACSR MOOSE Conductor for part of Diding – Dhalkebar – Bathnaha Transmission Line corresponding to Tower Package- TW02; associated with Arun-3 HEP in Nepal. | | |
| (Alternative, Deviations and Exceptions to the Provisions) | | |
| Bidder's Name and Address (Qualified Licensee): | | To: |
| Name : | | To: O/o Chief Engineer (P&C), SAPDC, Arun-3 HEP, Satluj Bhawan, Arun Sadan, Tumlingtar, Distt. Sankhuwasabha, Nepal Ph. +977-29- 575154, Mob.: +977-9852099789/+91- 9816072198. |
| Address : | | |

Dear Sir,

The bidder shall itemize any deviation from the Specifications included in his bid. Each item shall be listed (separate sheets may be used and enclosed with this Attachment) with the following information:

| Sl. No. | Reference clause in the Specifications | Deviation | Cost of withdrawal of the deviation |
|---------|--|-----------|-------------------------------------|
| | | | |

The above deviations and variations are exhaustive. We confirm that we shall withdraw the deviations proposed by us at the cost of withdrawal indicated in this attachment, failing which our bid may be rejected and Bid Security forfeited.

Except for the above deviations and variations, the entire work shall be performed as per your specifications and documents. Further, we agree that any deviations, conditionality or reservation introduced in this Attachment-6 and/or in the Bid form, Price schedules & Technical Data Sheets and covering letter, or in any other part of the bid will be reviewed to conduct a determination of the substantial responsiveness of the bid.

Date :

Name :

Place :

Designation :

For and on behalf of the bidder /Supplier

.....

(Name, Designation & Signature of authorized representative of the Bidder/Supplier, along with his name, Seal of Company)



| | | |
|---|--|--|
| Specification No.: SAPDC/P&C/Arun-3HEP/CD03/2023 (CD03) | | Attachment-7 (CD03) |
| Conductor Package (CD03) for Supply of ACSR MOOSE Conductor for part of Diding – Dhalkebar – Bathnaha Transmission Line corresponding to Tower Package- TW02; associated with Arun-3 HEP in Nepal. | | |
| (Details of Alternative Bid) | | |
| Bidder's Name and Address (Qualified Licensee): | | To: |
| Name : | | To: |
| Address : | | O/o Chief Engineer (P&C), SAPDC, Arun-3 HEP, Satluj Bhawan, Arun Sadan, Tumlingtar, Distt. Sankhuwasabha, Nepal Ph. +977-29-575154, Mob.: +977- 9852099789/+91-9816072198. |
| No Alternative Bid | | |
|  | | |

Date :

Name :

Place :

Designation :

For and on behalf of the bidder /Supplier

.....

(Name, Designation & Signature of authorized representative of the Bidder/Supplier, along with his name, Seal of Company)



| | | |
|---|--|--|
| Specification No.: SAPDC/P&C/Arun-3HEP/CD03/2023 (CD03) | | Attachment-8 (CD03) |
| Conductor Package (CD03) for Supply of ACSR MOOSE Conductor for part of Diding – Dhalkebar – Bathnaha Transmission Line corresponding to Tower Package- TW02; associated with Arun-3 HEP in Nepal. | | |
| (Manufacturer’s Authorization Form) <i>(On Manufacturer’s Letterhead, see Clause 9.3(c) of the ITB)</i> | | |
| Bidder’s Name and Address (Qualified Licensee): | | To: |
| Name : | | To: |
| Address : | | O/o Chief Engineer (P&C), SAPDC, Arun-3 HEP, Satluj Bhawan, Arun Sadan, Tumlingtar, Distt. Sankhuwasabha, Nepal Ph. +977-29-575154, Mob.: +977- 9852099789/+91-9816072198. |
| To: [Insert: name of Employer] | | |
| <p>Dear Ladies and/or Gentlemen,</p> <p>WE <i>[insert: name of Manufacturer]</i> who are established and reputable manufacturers of <i>[insert: name and/or description of the plant & equipment]</i> having production facilities at <i>[insert: address of factory]</i> do hereby authorize <i>[insert: name & address of Bidder]</i> (hereinafter, the “Bidder”) to submit a bid, and subsequently negotiate and sign the Contract with you against IFB <i>[insert: title and reference number of Invitation for Bids]</i> including the above plant & equipment or other goods produced by us.</p> <p>We hereby extend our full guarantee and warranty for the above specified plant & equipment materials or other goods offered supporting the supply, installation and achieving of Operational Acceptance of the plant by the Bidder against these Bidding Documents, and duly authorize said Bidder to act on our behalf in fulfilling these guarantee and warranty obligations. We also hereby declare that we and, <i>[insert: name of the Bidder]</i> have entered into a formal relationship in which, during the duration of the Contract (including warranty / defects liability) we, the Manufacturer or Producer, will make our technical and engineering staff fully available to the technical and engineering staff of the successful Bidder to assist that Bidder, on a reasonable and best effort basis, in the performance of all its obligations to the Purchaser under the Contract.</p> <p>For and on behalf of the Manufacturer</p> <p>Signed:</p> | | |



Date: _____

In the capacity of *[insert: **title of position or other appropriate designation**]* and this should be signed by a person having the power of attorney to legal bind the manufacturer.

Date : Name :

Place : Designation :

For and on behalf of the bidder /Supplier



.....

(Name, Designation & Signature of authorized representative of the Bidder/Supplier, along with his name, Seal of Company)



| | | |
|--|--|--|
| Specification No.: SAPDC/P&C/Arun-3HEP/CD03/2023 (CD03) | | Attachment-9 |
| Conductor Package(CD03) for Supply of ACSR MOOSE Conductor for part of Diding – Dhalkebar – Bathnaha Transmission Line corresponding to Tower Package- TW02; associated with Arun-3 HEP in Nepal. | | |
| (Work Completion Schedule) | | |
| Bidder's Name and Address (Qualified Licensee) | | To: |
| : | | |
| Name : | | To: |
| Address : | | O/o Chief Engineer (P&C), SAPDC, Arun-3 HEP, Satluj Bhawan, Arun Sadan, Tumlingtar, Distt. Sankhuwasabha, Nepal Ph. +977-29-575154, Mob.: +977- 9852099789/+91-9816072198. |

Dear Sir,

We hereby declare that the following Work Completion Schedule shall be followed by us in furnishing and installation of the subject Package i.e., Conductor Package-CD03 for supply of ACSR MOOSE Conductor for part of Diding – Dhalkebar – Bathnaha Transmission Line corresponding to Tower Package-TW02 associated with Arun-3 HEP in Nepal for the period commencing from the effective date of Contract to us :

| Sl. No. | Description of Work | Period in days from the effective date of contract i.e w.e.f date of issuance of NOA |
|---------|--|--|
| 1 | Submission of drawings for Approval | |
| 2 | Production of samples for type testing | |
| 3 | Completion of type tests | |
| 4 | Commencement of Commercial Production | |
| 5 | Offer of material for pre-despatch testing and inspection | |
| 6 | Commencement of shipment | |
| 7 | Completion of shipment (Receipt at final destination Site) | |

Date :

Name :



Place : _____ **Designation :** _____

Note : Bidders to enclose a detailed network covering all the activities to be undertaken for completion of the project indicating key dates for various milestones for each phase constituent-wise.

For and on behalf of the bidder /Supplier

.....

(Name, Designation & Signature of authorized representative of the Bidder/Supplier, along with his name, Seal of Company)





| | | |
|--|--|---|
| Specification No.: SAPDC/P&C/Arun-3HEP/CD03/2023 (CD03) | | Attachment-10 (CD03) |
| Conductor Package(CD03) for Supply of ACSR MOOSE Conductor for part of Diding – Dhalkebar – Bathnaha Transmission Line corresponding to Tower Package- TW02; associated with Arun-3 HEP in Nepal. | | |
| (Guarantee Declaration) | | |
| Bidder's Name and Address (Qualified Licensee) : | | To: |
| Name : | | To: |
| Address : | | O/o Chief Engineer (P&C), SAPDC, Arun-3 HEP, Satluj Bhawan, Arun Sadan, Tumlingtar, Distt. Sankhuwasabha, Nepal Ph. +977-29-575154, Mob.: +977- 9852099789/+91-9816072198. |

Dear Sir,

We conform that the equipments offered shall have minimum performance specified in Technical Specification. We further guarantee the performance/efficiency of the equipments in response to the Technical Specifications.



Date :

Name :

Place :

Designation :

For and on behalf of the bidder /Supplier

.....

(Name, Designation & Signature of authorized representative of the Bidder/Supplier, along with his name, Seal of Company)



| | | |
|---|--|--|
| Specification No.: SAPDC/P&C/Arun-3HEP/CD03/2023 (CD03) | | Attachment-11 (CD03) |
| Conductor Package (CD03) for Supply of ACSR MOOSE Conductor for part of Diding – Dhalkebar – Bathnaha Transmission Line corresponding to Tower Package- TW02; associated with Arun-3 HEP in Nepal. | | |
| (Information regarding ex-employees of Purchaser/ Consultant in Bidder's firm) | | |
| Bidder's Name and Address (Qualified Licensee) : | | To: |
| Name : | | To: O/o Chief Engineer (P&C), SAPDC, Arun-3 HEP, Satluj Bhawan, Arun Sadan, Tumlingtar, Distt. Sankhuwasabha, Nepal Ph. +977-29-575154, Mob.: +977-9852099789/+91-9816072198. |
| Address : | | |

Dear Sir,

We declare that we are aware of and have gone through the "Code of Business Conduct and Ethics for Senior Management Personnel"1 and "Code of Business Conduct and Ethics for Board Members"1 of SAPDC/SJVN (hereinafter referred to as the "Code of Conduct"). We further understand that as per the "Code of Conduct", Senior Management Personnel including Board Members, who have retired/resigned from SAPDC/SJVN, shall not accept any appointment or post, as detailed in the referred "Code of Conduct", within 1 year from the date of cessation of service/directorship unless approved by the Competent Authority.

Accordingly, we hereby furnish the details of ex-employees of SAPDC/SJVN who had retired/ resigned at the level of General Manager and above from SAPDC/ SJVN and subsequently have been employed by us:

| Sl. No. | Name of the person with designation in SAPDC/ SJVN | Date of Retirement/ resignation from SAPDC/ SJVN | Date of joining and designation in our organization* |
|---------|--|--|--|
| 1 | | | |
| 2 | | | |
| 3 | | | |
| 4 | | | |



| | | | |
|---|--|--|--|
| 5 | | | |
| 6 | | | |

*In case the date of joining in the bidder’s organization of such ex-employee is within 1 year from the date of retirement/resignation from SAPDC/ SJVN, No Objection Certificate/ approval from the Competent Authority must be furnished along with the bid or subsequent through clarification pursuant to ITB Clause 21.

In case of non-submission of No Objection Certificate/approval of the Competent Authority, as required, We understand that SAPDC shall deal with such cases as per its Policy and procedures in vogue, which may also result in rejection of our bid. We also confirm that SAPDC/SJVN shall be the sole judge in this regard.

We further declare that any misrepresentation or submission of false/forged documents/information in this regard shall be dealt with as per the provisions of the Integrity Pact and/or the Bidding Documents and/or SAPDC/SJVN’s policy and procedures.

Date :

Name :

Place :

Designation :



Note:

1. “Code of Business Conduct and Ethics for Senior Management Personnel” and “Code of Business Conduct and Ethics for Board Members” are available SJVN’s website www.sapdc.com.np & <https://www.sjvn.nic.in>

2. The information in similar format should be furnished for each partner of joint venture in case of joint venture bid.

3. In case bidder has furnished no details on ex-employees of SAPDC/ SJVN or has left blank or has indicated ‘-’ against the same, it shall be deemed that they have not employed any such person in their organization.

For and on behalf of the bidder /Supplier

.....

(Name, Designation & Signature of authorized representative of the Bidder/Supplier, along with his name, Seal of Company)



| | | |
|--|--|--|
| Specification No.: SAPDC/P&C/Arun-3HEP/CD03/2023 (CD03) | | Attachment-12 |
| Conductor Package (CD03) for Supply of ACSR MOOSE Conductor for part of Diding – Dhalkebar – Bathnaha Transmission Line corresponding to Tower Package- TW02; associated with Arun-3 HEP in Nepal. | | |
| (Price Adjustment Data) | | |
| Bidder's Name and Address (Qualified Licensee) : | | To: |
| | | |
| Name : | | To: |
| Address : | | O/o Chief Engineer (P&C), SAPDC, Arun-3 HEP, Satluj Bhawan, Arun Sadan, Tumlingtar, Distt. Sankhuwasabha, Nepal Ph. +977-29- 575154, Mob.: +977- 9852099789/+91-9816072198. |

Dear Sir,

We hereby furnish the relevant details pertaining to the price adjustment provisions for equipment as specified in your specifications and documents for the Conductor Package- CD03 for supply of ACSR MOOSE Conductor for part of Diding – Dhalkebar – Bathnaha Transmission Line corresponding to Tower Package-TW02 associated with Arun-3 HEP in Nepal. The necessary documentary evidence are enclosed:

| Sl. No. | Name of Materials | Value of co-efficient | Name of the published index | Value of index |
|---------|---|-----------------------|-----------------------------|----------------|
| 1 | 2 | 3 | 4 | 5 |
| 1 | EC grade aluminium ingots, co-efficient a = | 0.65 | | |
| 2 | | OPTION-A | | |
| | High Carbon Steel Rods , co-efficient b = | 0.13 | | |
| | High Tensile Galvanised Steel wires , co- | 0.02 | | |



| | | | | |
|--------|---|------|---|--|
| | efficient b = | | | |
| 3 | Labour, Co-efficient l= | 0.05 | Indian Labour Bureau, Shimla, Govt. of India (monthly) (Base: 2001 = 100) (www.labourbureau.nic.in) | |
| Note : | * Indicate the Publisher of Index for bidders who intend to quote their prices based on High Tensile Galvanized Steel Wire, the coefficient for the same (i.e. coefficient 'b' for High Tensile Galvanized Steel Wire) shall be 0.15 and coefficient 'c' shall not be applicable. | | | |

Date :

Name :

Place :

Designation :



For and on behalf of the bidder /Supplier

.....

(Name, Designation & Signature of authorized representative of the Bidder/Supplier, along with his name, Seal of Company)



| | | |
|---|--|---|
| Specification No.: SAPDC/P&C/Arun-3HEP/CD03/2023 (CD03) | | Attachment-13 (CD03) |
| Conductor Package (CD03) for Supply of ACSR MOOSE Conductor for part of Diding – Dhalkebar – Bathnaha Transmission Line corresponding to Tower Package- TW02; associated with Arun-3 HEP in Nepal. | | |
| (Declaration regarding Social Accountability) | | |
| Bidder's Name and Address (Qualified Licensee): | | To: |
| Name : | | To: |
| Address : | | O/o Chief Engineer (P&C), SAPDC, Arun-3 HEP, Satluj Bhawan, Arun Sadan, Tumlingtar, Distt. Sankhuwasabha, Nepal Ph. +977-29-575154, Mob.: +977- 9852099789/+91-9816072198. |

Dear Sir,

We conform that we stand committed to comply to all requirements of Social Accountability Standards i.e., SA8000 (latest Standard available at www.sa-intl.org) and maintain the necessary records.



Date :

Name :

Place :

Designation :

For and on behalf of the bidder /Supplier

.....

(Name, Designation & Signature of authorized
representative of the Bidder/Supplier, along with his name, Seal of Company)



| | | |
|---|--|--|
| Specification No.: SAPDC/P&C/Arun-3HEP/CD03/2023 (CD03) | | Attachment-14 (CD03) |
| Conductor Package (CD03) for Supply of ACSR MOOSE Conductor for part of Diding – Dhalkebar – Bathnaha Transmission Line corresponding to Tower Package- TW02; associated with Arun-3 HEP in Nepal. | | |
| (Integrity Pact)(Schedule-F) | | |
| Bidder's Name and Address (Qualified Licensee): | | To: |
| Name : | | To: |
| Address : | | O/o Chief Engineer (P&C), SAPDC, Arun-3 HEP, Satluj Bhawan, Arun Sadan, Tumlingtar, Distt. Sankhuwasabha, Nepal Ph. +977-29-575154, Mob.: +977- 9852099789/+91- 9816072198. |
| Dear Sir, | | |
| The Integrity Pact duly signed on behalf of SAPDC is enclosed at Schedule-F of the Bid Document. The Integrity Pact shall be downloaded, printed and signed by the bidder and the hard copy shall be submitted in Part-I (Envelope-I). | | |

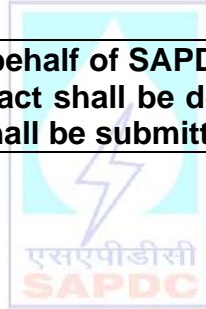

Date :

Name :

Place :

Designation :

For and on behalf of the bidder /Supplier

.....

(Name, Designation & Signature of authorized representative of the Bidder/Supplier, along with his name, Seal of Company)



| | | | |
|--|--|---|---------------------------------|
| Specification No.: SAPDC/P&C/Arun-3HEP/CD03/2023 (CD03) | | Attachment-15 (CD03) | |
| Conductor Package (CD03) for Supply of ACSR MOOSE Conductor for part of Diding – Dhalkebar – Bathnaha Transmission Line corresponding to Tower Package- TW02; associated with Arun-3 HEP in Nepal. | | | |
| (Option for Initial Advance (either Interest Bearing Initial Advance or No Initial Advance and Information for e-payment and PF details)) | | | |
| Bidder's Name and Address (Qualified Licensee) : | | To: | |
| Name : | | To: | |
| Address : | | O/o Chief Engineer (P&C), SAPDC, Arun-3 HEP, Satluj Bhawan, Arun Sadan, Tumlingtar, Distt. Sankhuwasabha, Nepal Ph. +977-29-575154, Mob.: +977- 9852099789/+91-9816072198. | |
| Dear Sir, | | | |
| I | We have read the provisions in the Bidding Documents regarding furnishing the option for advance payment. Accordingly, as per ITB Clause 9.3 as provided in Section BDS, Section III, Vol.-I of the Bidding Documents, we hereby confirm to opt the following: | | |
| | <u>Interest Bearing Initial Advance</u> | | |
| | Supply Portion: | <input type="checkbox"/> | Yes <input type="checkbox"/> No |
| II | We are furnishing the following details of Statutory Registration Numbers and details of Bank for electronic payment. | | |
| 1. | Name of the Supplier/ Contractor in whose favour payment is to be made | | |
| 2. | Address with PIN Code and State | | |
| | Registered Office: | | |
| | | | |
| | Branch Office: | | |
| | | | |
| | Correspondence Address: | | |
| | | | |
| | | | |



| | | |
|----|---|--|
| 3 | Permanent Account (PAN) No. | |
| 4 | PF Registration No. of the Company | |
| 5 | PF Regional Office covered (with Address) | |
| | | |
| 6 | Name of Contact Person | |
| | Designation | |
| 7 | Contact Details | |
| | Landline(s): | |
| | Mobile(s): | |
| | Email ID: | |
| 8 | Bank Details for Electronic Payment | |
| | Name of the Bank: | |
| | Address of Branch: | |
| | Account No.: | |
| | Type of Account: | |
| | Type of Account: | <input type="checkbox"/> Saving Acc <input type="checkbox"/> Current Acc |
| 9 | 9 digit MICR code printed at bottom in middle, next to cheque no. | |
| 10 | IFSC (for RTGS)/NEFT Code (<i>to be obtained from the Bank</i>) Sample Cancelled Cheque to be enclosed | |

We hereby declare that the above information are true and correct and we agree that the payment on account of this Contract, in the event of award, be made in the above account maintained in the above mentioned Bank.

Date : _____ **Name :** _____

Place : _____ **Designation :** _____

For and on behalf of the bidder /Supplier

.....

(Name, Designation & Signature of authorized representative of the Bidder/Supplier, along with his name, Seal of Company)



| | | |
|--|--------------------------|--|
| Specification No.: SAPDC/P&C/Arun-3HEP/CD03/2023 (CD03) | | Attachment-16 (CD03) |
| Conductor Package (CD03) for Supply of ACSR MOOSE Conductor for part of Diding – Dhalkebar – Bathnaha Transmission Line corresponding to Tower Package- TW02; associated with Arun-3 HEP in Nepal. | | |
| (Additional Information) | | |
| Bidder's Name and Address (Qualified Licensee): | | To: |
| Name : | | To: |
| Address: | | O/o Chief Engineer (P&C), SAPDC, Arun-3 HEP, Satluj Bhawan, Arun Sadan, Tumlingtar, Distt. Sankhuwasabha, Nepal Ph. +977-29-575154, Mob.: +977-9852099789/+91-9816072198. |
| Dear Sir, | | |
| In support of the additional information required as per ITB Sub-Clause 9.3 (p) of the Bidding Documents, we furnish herewith our data/details/documents etc., alongwith other information, as follows (the stipulations have been reproduced in italics for ready reference): | | |
| 1.0 | The Bidder shall furnish | |



| | | |
|-----|---|--|
| | <p><i>A certificate from their Banker(s) (as per prescribed formats in Form 16, Section-VI: Sample Forms and Procedures) indicating various fund based/non fund based limits sanctioned to the Bidder and the extent of utilization as on date. Such certificate should have been issued not earlier than three months prior to the date of bid opening. Wherever necessary the Employer may make queries with the Bidders' Bankers. [Reference ITB clause 9.3(p)(i)]</i></p> | |
| 1.1 | <p><i>In accordance with 1.0, certificate(s) from banker as per requisite format, indicating various fund based/non fund based limits sanctioned to the bidder or each member of the joint venture and the extent of utilization as on date is/are enclosed, as per the following details:</i></p> | |
| | Name of Bidder (Lead Partner) | |
| | Name of the Banker by whom certificate issued | |
| | Date of certificate (should not be earlier than 3 months prior to date of bid opening) | |
| | Whether fund based/non fund based limits are indicated in the certificate | |
| | Whether extent of utilization is indicated in the certificate | |
| 1.2 | <p><i>The Bidder should accordingly also provide the following information/documents</i></p> | |
| (i) | <p>Details of Banker:</p> | |
| | Name of Banker | |



| | | | | |
|------|--|-------------|------|---------------------------------|
| | Address of Banker | | | |
| | Telephone No. | | | |
| | Contact Name and Title | | | |
| | Fax No. | | | |
| | E-mail ID | | | |
| (ii) | As per para 1.0, Authorization Letter(s) from the bidder (in case of JV bidder, from all the partners) addressed to the Banker(s), authorizing SAPDC/SJVN to seek queries about the bidder with the Banker(s) and advising the Banker(s) to reply the same promptly, is/are enclosed as per following details: | | | |
| | Sl. No. | Letter Ref. | Date | Addressed to (name of the Bank) |
| | | | | |
| | | | | |
| 2.0 | Litigation History | | | |

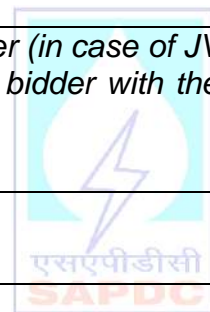



| | | | | | |
|---|------|---|------------------------------|---------------------------------|-----------------|
| <p><i>The bidder should provide detailed information on any litigation or arbitration arising out of contracts completed or under execution by it over the last five years. A consistent history of awards involving litigation against the Bidder or any partner of JV may result in rejection of Bid. [Reference ITB clause 9.3(p)(ii)]</i></p> | | | | | |
| <p>2.1 <i>Details of litigation history resulting from Contracts completed or under execution by the bidder over the last five years</i></p> | | | | | |
| | Year | Name of client, cause of litigation/arbitration and matter in dispute | Details of Contract and date | Award for or against the bidder | Disputed amount |
| | 1 | | | | |
| | 2 | | | | |
| | 3 | | | | |
| | 4 | | | | |
| | 5 | | | | |
| <p>3.0 Details regarding previous transgressions of Integrity Pact</p> | | | | | |



| | | |
|---|---|--|
| The bidder should provide detailed information on any transgression of Integrity Pact that occurred in the last 10 years with any other Public Sector Undertaking or Government Department or any other Company, in any country. | | |
| 3.1 Details regarding previous transgressions of Integrity Pact that occurred in the last 10 years | | |
| Year | Name of client | Details of Transgression of Integrity Pact by the bidder |
| | | |
| | | |
| | | |
| | | |
| | | |
| 4.0 | OTHER INFORMATION | |
| 4.1 | Current Contract Commitments of works in progress | |
| <i>Bidders (individual firms or each partners of JV) should provide information on their current commitments on all contracts that have been awarded, or for which a letter of intent or acceptance has been received, or for contracts approaching completion, but for which an unqualified, full completion certificate has yet to be issued.</i> | | |
| Details of Contract | Value of outstanding work (Rs.) | Estimated completion date |





| | | | | | | | | | | | |
|-----|-------------------|------------------------------|---------|---------|---------|---------|--------------------------------|---------|---------|---------|---------|
| | | | | | | | | | | | |
| | | | | | | | | | | | |
| | | | | | | | | | | | |
| | | | | | | | | | | | |
| | | | | | | | | | | | |
| | | | | | | | | | | | |
| 4.2 | Financial Data: | | | | | | | | | | |
| | Figures Rs in | | | | | | | | | | |
| | Details | Actual (Previous five years) | | | | | Projection for next five years | | | | |
| | | 2021/22 | 2020/21 | 2019/20 | 2018/19 | 2017/16 | 2022/23 | 2023/24 | 2024/25 | 2025/26 | 2026/27 |
| | Total Assets | | | | | | | | | | |
| | Current Assets | | | | | | | | | | |
| | Total Liability | | | | | | | | | | |
| | Current Liability | | | | | | | | | | |





| | | | | | | | | | | | |
|------------|---|--|--|--|--|--|--|--|--|--|----------------------|
| | Profit before taxes | | | | | | | | | | |
| | Profit after taxes | | | | | | | | | | |
| 5.0 | Details of Provident Fund Code Number of the Bidder [ref. ITB9.3(q)] | | | | | | | | | | |
| |  | | | | | | | | | | |
| | Date : | | | | | | | | | | Name : |
| | Place : | | | | | | | | | | Designation : |

For and on behalf of the bidder /Supplier

.....

(Name, Designation & Signature of authorized representative of the Bidder/Supplier, along with his name, Seal of Company)



| Specification No.: SAPDC/P&C/Arun-3HEP/CD03/2023 (CD03) | | Attachment-17 (CD03) | | |
|--|--|--|-------------------|-----------------|
| Conductor Package (CD03) for Supply of ACSR MOOSE Conductor for part of Diding – Dhalkebar – Bathnaha Transmission Line corresponding to Tower Package- TW02; associated with Arun-3 HEP in Nepal. | | | | |
| (Declaration for tax exemptions, reductions, allowances or benefits) | | | | |
| Bidder's Name and Address (Qualified Licensee) : | | To: | | |
| Name : | | To: | | |
| Address : | | O/o Chief Engineer (P&C), SAPDC, Arun-3 HEP, Satluj Bhawan, Arun Sadan, Tumlingtar, Distt. Sankhuwasabha, Nepal Ph. +977-29-575154, Mob.: +977-9852099789/+91-9816072198. | | |
| Dear Sir, | | | | |
| 1 | We confirm that we are solely responsible for obtaining following tax exemptions, reductions, allowances or benefits in respect of supplies under the subject package, in case of award. We further confirm that we have considered the same in our bid thereby passing on the benefit to Employer while quoting our prices. In case of our failure to receive such benefits, partly or fully, for any reason whatsoever, the Employer will not compensate us. | | | |
| 2 | We are furnishing the following information required by the Employer for issue of requisite certificate if and as permitted in terms of the applicable Govt. of Nepal policies/procedures (in case of award): | | | |
| Applicable Act, Notification No. and Clause Ref. No. | Sl. No. | Description of item on which applicable | Country of origin | Remarks, if any |
| | | | | |
| | | | | |
| | | | | |
| | | | | |



| | | | | |
|---|--|----------------------|--|--|
| | | | | |
| | | | | |
| <i>(The requirements listed above are as per current Notification of Govt. of Nepal indicated above. These may be modified, if necessary, in terms of the Notifications.)</i> | | | | |
| Date : | | Name : | | |
| Place : | | Designation : | | |

For and on behalf of the bidder /Supplier

.....

(Name, Designation & Signature of authorized representative of the Bidder/Supplier, along with his name, Seal of Company)





| | | | |
|---|--|--|--|
| Specification No.: SAPDC/P&C/Arun-HEP/CD03/2023 (CD03) | | Attachment-18 (CD03) | |
| Conductor Package (CD03) for Supply of ACSR MOOSE Conductor for part of Diding – Dhalkebar – Bathnaha Transmission Line corresponding to Tower Package- TW02; associated with Arun-3 HEP in Nepal. | | | |
| (Declaration) | | | |
| Bidder's Name and Address (Qualified Licensee) : | | To: | |
| Name : | | To: | |
| Address : | | O/o Chief Engineer (P&C), SAPDC, Arun-3 HEP, Satluj Bhawan, Arun Sadan, Tumlingtar, Distt. Sankhuwasabha, Nepal Ph. +977-29-575154, Mob.: +977-9852099789/+91-9816072198. | |
| Dear Sir, | | | |
| We confirm that Bid Form and Price Schedules in the Second Envelope have been filled up by us as per the provisions of the Instruction to Bidders. Further, we have noted that the same shall be evaluated as per the provisions of the Bidding Documents. | | | |
| Further, we hereby confirm that except as mentioned in the Attachment – 6 (Alternative, Deviations and Exceptions to the Provisions) hereof forming part of our First Envelope : | | | |
| (i) there are no discrepancies/inconsistencies and deviations/omissions/ reservations to the Bidding Documents, in the Second Envelope bid; | | | |
| (ii) the description of items and the unit thereof in the price schedules in the Second Envelope bid are in conformity with those indicated in the price schedule of the Bidding Documents without any deviation to the specified scope of work. We also confirm that in case any discrepancies/ inconsistencies and deviations/ omissions/ reservations, as referred to in para (i) and (ii) above, is observed in the Second Envelope, the same shall be deemed as withdrawn/rectified without any financial implication, whatsoever to Employer/SAPDC. However, in case of any arithmetical errors, the same shall be governed as per the provision of ITB Sub-Clause 27.2 read in conjunction with BDS. | | | |
| Date : | | Name : | |
| Place : | | Designation : | |

For and on behalf of the bidder /Supplier

.....

(Name, Designation & Signature of authorized representative of the Bidder/Supplier, along with his name, Seal of Company)



| | | |
|--|--|--|
| Specification No.: SAPDC/P&C/Arun-3HEP/CD03/2023 (CD03) | | Attachment-19 (CD03) |
| Conductor Package (CD03) for Supply of ACSR MOOSE Conductor for part of Diding – Dhalkebar – Bathnaha Transmission Line corresponding to Tower Package- TW02; associated with Arun-3 HEP in Nepal. | | |
| (Declaration of Key Managerial Person and Power of Attorney holder) | | |
| Bidder's Name and Address (Sole Bidder) : | | To: |
| Name : | | To: |
| Address : | | O/o Chief Engineer (P&C), SAPDC, Arun-3 HEP, Satluj Bhawan, Arun Sadan, Tumlingtar, Distt. Sankhuwasabha, Nepal Ph. +977-29-575154, Mob.: +977- 9852099789/+91-9816072198. |
| Dear Sir, | | |
| <p>1. We confirm that the declarations made in our bid, particularly Attachment-3 (QR) regarding eligibility/qualification data and documents submitted in our bid in support of the declarations, are true and correct to the best of our knowledge.</p> <p>2. We further confirm that we have filled up Attachment-3(QR). We also confirm that in support of meeting the Technical experience requirement as per Annexure-A (BDS), we have enclosed self-certified copy of Contract/ Award Letter and certificate from the utility for which the contract has been executed.</p> <p>3. We shall furnish clarification to bid, if any sought by Purchaser pursuant to ITB clause 21.1. We understand that if we fail to rectify/furnish the requested documents if any, within 7 working days' notice, our bid is liable to be rejected.</p> <p>4. We understand that any false declaration and/or misrepresentation of facts and/or furnishing of false/forged documents /information may lead to our debarment from participation in Purchaser tenders and that our Bid Security/ Contract Performance Guarantee may be forfeited besides other actions as deemed to be appropriate as per the provisions of the Bidding Document/Integrity Pact/Purchaser's policy.</p> <p>5. Our/Our proposed manufacturer's annual manufacturing capacity as certified by a Chartered Engineer or similar Professional/ Professional body/Govt Agencies is</p> | | |
| | km of equivalent ACSR MOOSE conductor /annum | |



[Certificate from Chartered Engineer or similar Professional/ Professional body/Govt Agencies in the country of the bidder/proposed manufacturer is to be enclosed along with this Attachment. Annual manufacturing capacity of all the manufacturers to be furnished separately]

6. Notwithstanding above, we also understand that the Bid Capacity/Manufacturing Capacity as declared hereinabove, shall be subject to assessment, if any, by the Purchaser, which shall be final and binding. We also confirm that the Purchaser may verify the supporting documents/ details in connection with above declarations. We further understand that in case of any unethical practices inter-alia including any misrepresentation of facts, submission of false and/or forged details/ documents/ declaration by us, we may be debarred from the participation in Purchaser's tenders in future as considered appropriate by Purchaser and our Bid Security/ Contract Performance Guarantee shall be forfeited besides taking other actions as deemed appropriate.

| | | | |
|----------------|--|----------------------|--|
| Date : | | Name : | |
| Place : | | Designation : | |

Note: Key Managerial Personnel (KMP) of the company shall include CEO/Managing Director/ Company Secretary/ Director/ CFO/any of the partner in case of partnership firm/any other officer entrusted with substantial powers of the management of the affairs of the company/firm.



For and on behalf of the bidder /Supplier

.....

(Name, Designation & Signature of authorized representative of the Bidder/Supplier, along with his name, Seal of Company)



| | | |
|--|--|--|
| Specification No.: SAPDC/P&C/Arun-3HEP/CD03/2023 (CD03) | | Attachment-21 |
| Conductor Package (CD03) for Supply of ACSR MOOSE Conductor for part of Diding – Dhalkebar – Bathnaha Transmission Line corresponding to Tower Package- TW02; associated with Arun-3 HEP in Nepal. | | |
| (Compliance to the process related to the e-RA Terms & Conditions and the Business Rules governing the e-RA) | | |
| Bidder's Name and Address (Qualified Licensee): | | To: |
| Name : | | To: |
| Address : | | O/o Chief Engineer (P&C), SAPDC, Arun-3 HEP, Satluj Bhawan, Arun Sadan, Tumlingtar, Distt. Sankhuwasabha, Nepal Ph. +977-29-575154, Mob.: +977- 9852099789/+91- 9816072198. |
| Dear Sir, | | |
| This has reference to the Terms & Conditions for the e-Reverse Auction mentioned in the Business Rules for Conductor Package- CD03 for supply of ACSR MOOSE Conductor for part of Diding – Dhalkebar – Bathnaha Transmission Line corresponding to Tower Package-TW02 associated with Arun-3 HEP in Nepal. | | |
| We confirm that: | | |
| 1) The undersigned is authorized representative of the Bidder. | | |
| 2) We have studied the e-Reverse Auction Terms & Conditions and the Business Rules governing the e-Reverse Auction as mentioned in your letter and confirm our agreement to them. | | |
| 3) We understand that ASP shall arrange to demonstrate/ train (if not trained earlier) bidders' nominated person(s), without any cost. They will also explain all the Rules related to e-Reverse Auction/ Business Rules Document to be adopted along with bid manual. We have further noticed that we at own discretion may ask for additional training to use the e-RA platform well in advance before start of the e-RA event by contacting the ASP at any suitable time. All such additional trainings shall also be free of cost. | | |



4) We further re-confirm that within an hour of conclusion of e-Reverse Auction, we will submit confirmation of our final offered price in e-Reverse Auction including the break-up under individual head of the template [i.e. **CIP Entry Border Point/Ex-works Price, Port handling & Custom clearance, Local Transportation, In-transit Insurance, loading and unloading charges etc., as applicable**] Further, unless other-wise stated in the above break-up, decrease in the price of individual head of the template shall be considered proportionately on all individual line items of the respective head of the price schedules. In case, there is any variation between our final price quoted in Reverse Auction and the signed document submitted by us after Auction, the first i.e. Closing Price in Auction, shall be taken as final offered price by us. We also confirm that we will not increase unit rate of any item submitted in our original bid.

We hereby confirm that we will honor the Bids placed by us during the auction process.

| | | | |
|----------------|--|----------------------|--|
| Date : | | Name : | |
| Place : | | Designation : | |



For and on behalf of the bidder /Supplier

.....

(Signature of authorized representative of the Bidder/Supplier, along with his name, Seal of Company)



| | | | |
|---|--|---|--|
| Specification No: SAPDC/P&C/Arun-3HEP/CD03/2023 (CD03) | | Bid Form 1st Envelope | |
| BID FORM (First Envelope) | | | |
| Bid Proposal Ref. No. | | | |
| Date : | | | |
| To: | | | |
| To: O/o Chief Engineer (P&C), SAPDC, Arun-3 HEP, Satluj Bhawan, Arun Sadan, Tumlingtar, Distt. Sankhuwasabha, Nepal Ph. +977-29-575154, Mob.: +977-9852099789/+91-9816072198. | | | |
| Name of Contract : | | Conductor Package (CD03) for Supply of ACSR MOOSE Conductor for part of Diding – Dhalkebar – Bathnaha Transmission Line corresponding to Tower Package- TW02; associated with Arun-3 HEP in Nepal. | |
| Dear Ladies and/or Gentlemen, | | | |
| 1.0 | Having examined the Bidding Documents, including Amendment Nos. ...[Enter the Amendment]... dated ...[Enter the Date in dd-mm-yyyy]... the receipt of which is hereby acknowledged, we the undersigned, offer to design, manufacture, test, deliver, install and commission (including carrying out Trial operation, Performance & Guarantee Test as per the provision of Technical Specification) the Facilities under the above-named package in full conformity with the said Bidding Documents. In accordance with ITB Clause 9.1 of the Bidding Documents, as per which the bid shall be submitted by the bidder under “Single Stage - Two Envelope” procedure of bidding. Accordingly, we hereby submit our Bid, in two envelopes i.e. First Envelope – Techno – Commercial Part & Second Envelope - Price Part (to be opened subsequently). | | |
| | The above amounts are in accordance with the price schedules attached herewith and are made part of this bid | | |
| 1.1 | We meet the eligibility requirements and have no conflict of interest in accordance with ITB Clause 2 | | |
| 2.0 | Attachments to the Bid Form (First Envelope) | | |
| 2.1 | In line with the requirement of the Bidding Documents, we enclose herewith the following Attachments: | | |



| | | |
|--|-----------------------------|--|
| | (a) Attachment 1((CD03)) : | Bid Security, in a the Envelope-I , in the form of for a sum of INR/NPR..... initially valid upto |
| | (b) Attachment 2((CD03)) : | A power of attorney duly authorized by a Notary Public indicating that the person(s) signing the bid have the authority to sign the bid and thus that the bid is binding upon us during the full period of its validity in accordance with the ITB Clause 14. |
| | (c) Attachment 3((CD03)) : | The documentary evidence that we are eligible to bid in accordance with ITB Clause 2. Further, in terms of ITB Clause 9.3 (c) & (e), the qualification data has been furnished as per your format enclosed with the bidding documents Attachment-3(QR). |
| | (d) Attachment 4((CD03)) : | The documentary evidence establishing in accordance with ITB Clause 3, Vol.-I of the Bidding Documents that the facilities offered by us are eligible facilities and conform to the Bidding Documents has been furnished as Attachment 4. A list of Special Tools & Tackles to be used by us for erection, testing & Commissioning and to be handed over to Employer, the cost of which is included is our Bid Price, is also enclosed as per your format as Attachment 4A. A list of Special Tools & Tackles to be brought by the contractor for erection, testing & Commissioning and to be taken back after completion of work, whose cost in not included in our bid price, is enclosed as per your format as Attachment 4B. |
| | (e) Attachment 5((CD03)) : | The details of all major items of services or supply which we propose subletting in case of award, giving details of the name and nationality of the proposed subcontractor/sub-vendor for each item. |
| | (f) Attachment 5A((CD03)) : | Not Applicable |



| | | |
|--|-----------------------------|---|
| | (g) Attachment 6((CD03)) : | The variation and deviations from the requirements of the Conditions of Contract, Technical Specification and Drawings (excluding critical provisions as mentioned at clause 6.0 below) in your format enclosed with the Bidding Documents, including, inter alia, the cost of withdrawal of the variations and deviations indicated therein. |
| | (h) Attachment 7((CD03)) : | The details of Alternative Bids made by us indicating the complete Technical Specifications and the deviation to contractual and commercial conditions. (Not Applicable) |
| | (i) Attachment 8((CD03)) : | Manufacturer's Authorisation Forms. |
| | (j) Attachment 9((CD03)) : | Work Completion Schedule. |
| | (k) Attachment 10((CD01)) : | Guarantee Declaration. |
| | (l) Attachment 11((CD01)) : | Information regarding ex-employees of Purchaser/ Consultant in Bidder's firm |
| | (m) Attachment 12((CD01)) : | Filled up information regarding Price Adjustment Data as per the format enclosed in the bidding documents. |
| | (n) Attachment 13((CD01)) : | Declaration regarding Social Accountability. |
| | (o) Attachment 14((CD01)) : | Integrity Pact, in a Envelope-I, duly filled signed & stamped on each page by the person signing the bid. |
| | (p) Attachment 15((CD01)) : | Option for Initial Advance (either Interest Bearing Initial Advance or No Initial Advance) and Information for e – payment and PF details. |
| | (q) Attachment 16((CD01)) : | Additional Information. |
| | (r) Attachment 17((CD01)) : | Declaration for tax exemptions, reductions, allowances or benefits |
| | (s) Attachment 18((CD01)) : | Declaration. |



| | | |
|-----|--|---|
| | (t) Attachment 19((CD01)) : | Declaration of Key Managerial Person and Power of Attorney holder |
| | (u) Attachment 20((CD01)) : | Unequivocal consent of the proposed Associate(s) for the purpose of executing the "Second Contract" and/ or "Third Contract" as an independent Contractor (applicable to Foreign Bidders) - Not Applicable |
| | (v) Attachment 21((CD01)) : | Compliance to the process related to the e-RA Terms & Conditions and the Business Rules governing the e-RA |
| 3.0 | We are aware that, in line with Clause No. 27.1 (ITB), our Second Envelope (Price Part) is liable to be rejected in case the same contains any deviation/omission from the contractual and commercial conditions and technical Specifications other than those identified in this First Envelope. | |
| 3.1 | We are aware that the Price Schedules do not generally give a full description of the Work to be performed under each item and we shall be deemed to have read the Technical Specifications and other sections of the Bidding Documents and Drawings to ascertain the full scope of Work included in each item while filling-in the rates and prices in <u>Second Envelope</u> . | |
| 3.2 | We declare that as specified in Clause 11.5, Section –II:ITB, Vol.-I of the Bidding Documents, prices quoted by us in the Price Schedules in <u>Second Envelope</u> shall be subject to Price Adjustment during the execution of Contract in accordance with Appendix-2 (Price Adjustment) to the Contract Agreement. | |
| 4.0 | We confirm that except as otherwise specifically provided our Bid Prices in Second Envelope include all taxes, duties, levies and charges as may be assessed on us, our Sub-Contractor/Sub-Vendor or their employees by all municipal, state or national government authorities in connection with the Facilities, in and outside of Nepal. | |
| 5.0 | Construction of the Contract | |



| | | | |
|-----|---|----------|----------------------|
| 5.1 | <p>We declare that we have studied Clause GCC 2.1 relating to mode of contracting for Foreign Bidders and we are making this proposal with a stipulation that you shall award us two separate Contracts viz 'First Contract' for CIP Entry Border Point supply of all equipments and materials including mandatory spares to be supplied from Abroad, Type Test to be conducted Abroad and Training to be imparted Abroad (if applicable); 'Second Contract' for providing all services i.e., port handling and custom clearance of imported goods under CIP Entry Border Point Contract and loading, inland transportation for delivery at site, In-transit insurance, unloading, Supervision Charges (if applicable), handling at site, storage and any other services specified in the Contract documents..</p> <p>We declare that the award of two contracts, will not, in any way, dilute our responsibility for successful operation of plant/equipment and fulfillment of all obligations as per Bidding Documents and that both the Contracts will have a cross-fall breach clause i.e. a breach in one Contract will automatically be classified as a breach of the other contracts which will confer on you the right to terminate the other contract at our risk and cost.</p> | | |
| | <p>We declare that we have studied Clause GCC 2.1 relating to mode of contracting for Nepalese Bidder and we are making this proposal with a stipulation that you shall award us two separate Contracts viz 'First Contract' for Ex-Works Supply of equipment & materials to be supplied from within Nepal and Type Test to be conducted in Nepal and/ or Abroad. (if applicable) and 'Second Contract' Contract' for providing all services i.e., inland transportation, In-transit insurance, loading and delivery at site and Supervision Charges, if applicable, handling at site, storage and any other services specified in the Contract Documents.</p> <p>We declare that the award of two contracts, will not, in any way, dilute our responsibility for successful operation of plant/equipment and fulfillment of all obligations as per Bidding Documents and that both the Contracts will have a cross-fall breach clause i.e. a breach in one Contract will automatically be classified as a breach of the other contracts which will confer on you the right to terminate the other contract at our risk and cost.</p> | | |
| 6.0 | <p>We have read the provisions of following clauses and confirm that the specified stipulations of these clauses are acceptable to us:</p> | | |
| | (a) | GCC 2.14 | Governing Law |
| | (b) | GCC 8 | Terms of Payment |
| | (c) | GCC 9.3 | Performance Security |



| | | | |
|------|--|--|---------------------------|
| | (d) | GCC 10 | Taxes and Duties |
| | (e) | GCC 21.2 | Completion Time Guarantee |
| | (f) | GCC 22 | Defect Liability |
| | (g) | GCC 24 | Patent Indemnity |
| | (h) | GCC 25 | Limitation of Liability |
| | (i) | GCC 35 | Settlement of Disputes |
| | (j) | GCC 36 | Arbitration |
| | (k) | Appendix 2 to Form of Contract Agreement | Price Adjustment |
| | Further we understand that deviation taken in any of the above clauses by us may make our bid non-responsive as per provision of bidding documents and be rejected by you. | | |
| 7.0 | We undertake, if our bid is accepted, to commence the work immediately upon your Notification of Award to us, and to achieve the delivery of goods and related services within the time stated in the Bidding Documents. | | |
| 8.0 | If our bid is accepted, we undertake to provide a Performance Security in the form and amounts, and within the times specified in the Bidding Documents. | | |
| 9.0 | We agree to abide by this bid for a period of six (06) months from the date fixed for opening of bids as stipulated in the Bidding Documents, and it shall remain binding upon us and may be accepted by you at any time before the expiration of that period. | | |
| 10.0 | Until a formal Contract is prepared and executed between us, this bid, together with your written acceptance thereof in the form of your Notification of Award shall constitute a binding contract between us. | | |
| 11.0 | We understand that you are not bound to accept the lowest or any bid you may receive. | | |
| 12.0 | We, hereby, declare that only the persons or firms interested in this proposal as principals are named here and that no other persons or firms other than those mentioned herein have any interest in this proposal or in the Contract to be entered into, if the award is made on us, that this proposal is made without any connection with any other person, firm or party likewise submitting a proposal is in all respects for and in good faith, without collusion or fraud. | | |



| | | | |
|--|--|---|--|
| | | Thanking you, we remain, Yours faithfully, For and on behalf of | |
| | | | |
| Date : | | Name : | |
| Place : | | Designation: | |
| For and on behalf of the bidder /Supplier | | | |
| (Name, Designation & Signature of authorized representative of the Bidder/Supplier, along with his name, Seal of Company) | | | |
| In case of bid from a Joint Venture, name & designation of representative of JV partner is to be provided and Bid Form is also to be signed by him | | | |
| Other Partner -1 | | Other Partner -2 | |
| Name: | | Name: | |
| Designation : | | Designation: | |
| Please provide additional information of the Bidder | | | |
| Business Address : | | | |
| | | | |
| Country of Incorporation : | | | |
| State/Province to be indicated : | | | |
| Name of Principal Officer : | | | |
| Address of Principal Officer : | | | |



| | |
|---|--|
| | |
| | |
| Note: Bidders may note that no prescribed proforma has been enclosed for Attachment 2((CD03)) Power of Attorney. Bidders may use their own proforma for furnishing the required information with the bid. | |

For and on behalf of the bidder /Supplier

.....

(Name, Designation & Signature of authorized representative of the Bidder/Supplier, along with his name, Seal of Company)



| Section | Description |
|---|---|
| Volume-III : Bid Form, Price Schedules & Technical Data Sheets | |
| Section-II | Bid Form & Price Schedules Under Envelope-II along with Price bid |

Submission: price bid Under Envelope-II shall be submitted only through SJVN e-portal (by filling price part in electronic form/template & uploading soft/scanned copy of Dully filled, Signed & stamped of bid form & Schedules under Envelope-II) (Not in Hard copy)





| | |
|--|--|
| I. General guideline for filling up the Price Schedule, Sch-1 to Sch-6 | |
| Conductor Package (CD03) for Supply of ACSR MOOSE Conductor for part of Diding – Dhalkebar – Bathnaha Transmission Line corresponding to Tower Package- TW02; associated with Arun-3 HEP in Nepal. | |
| SPEC. NO.: SAPDC/P&C/Arun-3HEP/CD03/2023 (CD03) | |
| 1. | Rates should be filled in both figures and words. In case of ambiguities in between the rate in figures and the rate in words, the rate quoted in words shall prevail and the amount shall be corrected accordingly. The SAPDC reserves the right to adjust arithmetical or other errors in any tender/quotation in the way which it considers suitable. |
| 5. | All the cell of Schedule shall fill as applicable to the bidder. If not applicable then mentioned as Not Applicable. |
| 6. | Schedule 1a Applicable for “Goods to be supplied from abroad (i.e. Outside Nepal) including Type Test Charges for Type Tests to be conducted abroad” (filling price part in electronic form/template on SJVN e-portal) |
| 7. | Schedule 1b: Applicable for “Goods to be supplied from within Nepal, including Type Test Charges” |
| 8. | Schedule 2: Port handling and Custom clearance of Goods supplied from abroad, if applicable & Local/inland Transportation, In-transit insurance and loading. (filling price part in electronic form/template on SJVN e-portal) |
| 9. | Schedule 3:Supervision of Installation Services (NOT APPLICABLE) |
| 10 | Schedule 4: The Customs duty/Bhansar/Other Taxes & Duties, included in Bid Prices i.e in Schedule 1 to 3 , as applicable shall be indicated separately in this Schedule. (uploading soft/scanned copy of Dully filled, Signed & stamped of Schedule 4: under Envelope-II on SJVN e-portal) (Not in Hard copy) |
| 11. | Schedule 5:Grand Summary (Schedule Nos. 1 to 3) (filling price part in electronic form/template or calculated automatic) |
| 12. | Schedule 6a: Break-up of Type Test Charges for Type Tests to be conducted abroad (NOT APPLICABLE) |
| 13. | Schedule 6b: Break-up of Type Test Charges for Type Tests to be conducted in India (NOT APPLICABLE) |
| 14. | uploading soft/scanned copy of Dully filled, Signed & stamped copy of bid form under Envelope-II on SJVN e-portal |



| | | |
|-----------|---|---|
| II | This workbook contains the following worksheets: | |
| (a) | Cover : | Details of the bidder |
| (c) | Sch-1(a): | Plant and Equipment (including Mandatory Spares Parts) to be supplied from Abroad (i.e. outside Nepal), including Type Test Charges for tests to be conducted abroad |
| (d) | Sch-1(b): | Plant and Equipment (including Mandatory Spares Parts) to be supplied from within Nepal |
| (e) | Sch-2: | Port handling & Custom clearance for Plant & equipment to be supplied from Abroad as per Schedule-1a (if any); and Local Transportation, In-transit Insurance, loading and unloading etc. for all Plant & equipment to be supplied as per Schedules-1a & 1b |
| (f) | Sch-3: | Schedule of rates and prices for Supervision of Installation Services |
| (g) | Sch-4: | Taxes & Duties included in the Bid Price. |
| (h) | Sch-5 : | Grand Summary |
| (i) | Sch-6(a): | Schedule of Type Test Charges for Type Tests to be conducted Abroad (i.e. outside Nepal): |
| (j) | Sch-6(b): | Schedule of Type Test Charges for Type Tests to be conducted in Nepal: |
| (k) | Bid Form (2nd Envelope): | |
| | Fill up ref. no. as bidder's ref. no. of this letter. | |
| | This letter shall consider the net price as per Sch-5 | |
| | Fill up names & Designation of the Bidder. | |
| | Fill up additional Information as required. | |



| | | |
|---|--|-----------------------|
| Cover : | | Details of the bidder |
| Conductor Package (CD03) for Supply of ACSR MOOSE Conductor for part of Diding – Dhalkebar – Bathnaha Transmission Line corresponding to Tower Package- TW02; associated with Arun-3 HEP in Nepal. | | |
| SPEC. NO.: SAPDC/P&C/Arun-3HEP/CD03/2023 (CD03) | | |
| Specify type of Bidder | | |
| Name of Qualified Licensee | | |
| Address of Qualified Licensee | | |
| Name of Qualified Manufacturer (the Licenser) | | |
| Address of Licenser |  | |
| Contact Person mobile number | | |
| Name | | |
| Designation | | |
| Date | | |
| Place | | |

For and on behalf of the bidder /Supplier

.....

(Name, Designation & **Signature of authorized representative of the Bidder/Supplier, along with his name, Seal of Company**)



| Schedule-1a | | | | | | | | | | |
|---|---|-------------------|--------------------|------|------|----------|---|------------|-------------------------------|------------------|
| Goods to be supplied from abroad (i.e. Outside Nepal) including Type Test Charges for Type Tests to be conducted abroad: | | | | | | | | | | |
| SPEC. NO.: SAPDC/P&C/Arun-3HEP/CD03/2023 (CD03 | | | | | | | | | | |
| Conductor Package (CD03) for Supply of ACSR MOOSE Conductor for part of Diding – Dhalkebar – Bathnaha Transmission Line corresponding to Tower Package- TW02; associated with Arun-3 HEP in Nepal. | | | | | | | | | | |
| (Schedule of Rates and Prices) | | | | | | | | | | |
| 1 | 2 | 3 | 4 | 5 | 6 | 7 | 8 | | | (9)=(6x8) |
| S. No. | Item Description | Country of Origin | Type & Designation | Unit | Qty. | Currency | Unit CIP Border Point Price | | Total CIP Border Point Amount | |
| | | | | | | | (including all Taxes & Duties) (In INR/NPR) | | | Price (In words) |
| | | | | | | | (In figures) | (In words) | | |
| 1. | ACSR MOOSE CONDUCTOR | | | KM | 2799 | | | | | |
| A | Total Amount CIP Border Point Amount (including all Taxes & Duties) (In INR/NPR) | | | | | | | | | |
| Bidder's Name and Address | | | | | | | To: O/o Chief Engineer (P&C), SAPDC, Arun-3 HEP, Satluj Bhawan, Arun Sadan, Tumlingtar, Distt. Sankhuwasabha, Nepal Ph. +977-29-575154, Mob.: +977-9852099789/+91-9816072198. | | | |
| For and on behalf of the bidder /Supplier | | | | | | | | | | |
| (Name, Designation & Signature of authorized representative of the Bidder/Supplier, along with his name, Seal of Company) | | | | | | | | | | |



| Schedule-1b | | | | | | | | | |
|---|---|-------------------|--------------------|------|------|--|---|------------|---|
| Goods to be supplied from within Nepal, including Type Test Charges : | | | | | | | | | |
| SPEC. NO.: SAPDC/P&C/Arun-3HEP/CD03/2023 (CD03) | | | | | | | | | |
| Conductor Package (CD03) for Supply of ACSR MOOSE Conductor for part of Diding – Dhalkebar – Bathnaha Transmission Line corresponding to Tower Package- TW02; associated with Arun-3 HEP in Nepal. | | | | | | | | | |
| (Schedule of Rates and Prices) | | | | | | | | | |
| 1 | 2 | 3 | 4 | 5 | 6 | 7 | 8 | (9)=(6x8) | |
| S. No. | Item Description | Country of Origin | Type & Designation | Unit | Qty. | Currency | Unit Ex-Works Price (including all Taxes and Duties) (In INR/NPR) | | Total Ex-Works Price (including all Taxes and Duties)(In INR/NPR) |
| | | | | | | | (In figures) | (In words) | |
| 1. | ACSR MOOSE CONDUCTOR | | | KM | 2799 | | | | |
| A | Total Amount CIP Border Point Amount (including all Taxes & Duties) (In INR/NPR) | | | | | | | | |
| Bidder's Name and Address: | | | | | | To: O/o Chief Engineer (P&C), SAPDC, Arun-3 HEP, Satluj Bhawan, Arun Sadan, Tumlingtar, Distt. Sankhuwasabha, Nepal Ph. +977-29-575154, Mob.: +977-9852099789/+91-9816072198. | | | |
| For and on behalf of the bidder /Supplier | | | | | | | | | |
| (Name, Designation & Signature of authorized representative of the Bidder/Supplier, along with his name, Seal of Company) | | | | | | | | | |



| Schedule-2 | | | | | | | | | |
|---|---|-------------------|--------------------|------|------|--|---|------------|--|
| Port handling and Custom clearance of Goods supplied from abroad, if applicable & Local/inland Transportation, In-transit insurance and loading Port handling & Custom clearance, Local/inland Transportation, In-transit Insurance, Loading & Unloading Charges (including all Taxes and Duties)(Port Handling & Custom Clearance Charges applicable only for CIF supplies covered under Schedule-1a) | | | | | | | | | |
| SPEC. NO.: SAPDC/P&C/Arun-3HEP/CD03/2023 (CD03) | | | | | | | | | |
| Conductor Package (CD03) for Supply of ACSR MOOSE Conductor for part of Diding – Dhalkebar – Bathnaha Transmission Line corresponding to Tower Package- TW02; associated with Arun-3 HEP in Nepal. | | | | | | | | | |
| (Schedule of Rates and Prices) | | | | | | | | | |
| 1 | 2 | 3 | 4 | 5 | 6 | 7 | 8 | (9)=(6x8) | |
| S. No. | Item Description | Country of Origin | Type & Designation | Unit | Qty. | Currency | Unit Charge (including all Taxes & Duties) (In INR/NPR) | | Total Amount (including all Taxes & Duties) (In INR/NPR) |
| | | | | | | | (In figures) | (In words) | |
| 1. | ACSR MOOSE CONDUCTOR | | | KM | 2799 | | | | |
| B | Total Amount (including all Taxes & Duties) (In INR/NPR) | | | | | | | | |
| Bidder's Name and Address: | | | | | | To: O/o Chief Engineer (P&C), SAPDC, Arun-3 HEP, Satluj Bhawan, Arun Sadan, Tumlingtar, Distt. Sankhuwasabha, Nepal Ph. +977-29-575154, Mob.: +977-9852099789/+91-9816072198. | | | |
| For and on behalf of the bidder /Supplier | | | | | | | | | |
| (Name, Designation & Signature of authorized representative of the Bidder/Supplier, along with his name, Seal of Company) | | | | | | | | | |



| Schedule-3 | | | | | | | | | |
|--|----------------------|-------------------|--------------------|------|------|----------|---|------------|---|
| Goods to be supplied from within Nepal, including Type Test Charges : | | | | | | | | | |
| SPEC. NO.: SAPDC/P&C/Arun-3HEP/CD03/2023 (CD03) | | | | | | | | | |
| Conductor Package (CD03) for Supply of ACSR MOOSE Conductor for part of Diding – Dhalkebar – Bathnaha Transmission Line corresponding to Tower Package- TW02; associated with Arun-3 HEP in Nepal. | | | | | | | | | |
| (Schedule of Rates and Prices) | | | | | | | | | |
| 1 | 2 | 3 | 4 | 5 | 6 | 7 | 8 | | (9)=(6x8) |
| S. No. | Item Description | Country of Origin | Type & Designation | Unit | Qty. | Currency | Unit Ex-Works Price (including all Taxes and Duties) (In INR) | | Total CIP Border Point Amount (including all Taxes & Duties) (In INR) |
| | | | | | | | (In figures) | (In words) | |
| 1. | ACSR MOOSE CONDUCTOR | | | KM | 2799 | | | | |
|  NOT APPLICABLE | | | | | | | | | |



| SUMMARY OF TAXES & DUTIES | | SCHEDULE-4 |
|--|--|--|
| Conductor Package (CD03) for Supply of ACSR MOOSE Conductor for part of Diding – Dhalkebar – Bathnaha Transmission Line corresponding to Tower Package- TW02; associated with Arun-3 HEP in Nepal. | | |
| SPEC. NO.: SAPDC/P&C/Arun-3HEP/CD03/2023 (CD03) | | |
| SUMMARY OF TAXES & DUTIES | | |
| Sl. No. | Name of Taxes and Duties applicable within Nepal | Rate (in %) |
| 1. | Name of Taxes & Duties included in Schedule 1a: | |
| | | |
| | | |
| 2. | Name of Taxes & Duties included in Schedule 1b: | |
| | | |
| | | |
| 3. | Name of Taxes & Duties included in Schedule 2: | |
| | | |
| | | |
| 4. | Name of Taxes & Duties included in Schedule 3 : | Not Applicable |
| Note | The Taxes and Duties for which rate is indicated above are already included in Bid Prices of respective Schedules. In line with ITB 11.4 (p) in BDS Section-II of the Bidding Documents for the purpose of Evaluation Total Bid Prices, which are inclusive of Taxes and Duties, quoted by Bidder shall be considered. | |
| | Bidder's Name and Address: | To: O/o Chief Engineer (P&C), SAPDC, Arun-3 HEP, Satluj Bhawan, Arun Sadan, Tumlingtar, Distt. Sankhuwasabha, Nepal Ph. +977-29- 575154, Mob.: +977-9852099789/+91- 9816072198. |
| For and on behalf of the bidder /Supplier | | |
| (Name, Designation & Signature of authorized representative of the Bidder/Supplier, along with his name, Seal of Company) | | |



| | | | | |
|---|--|------------------------------------|---|--|
| SPEC. NO.: SAPDC/P&C/Arun-3HEP/CD03/2023 (CD03) | | | | |
| SCHEDULE-5 | | | | |
| Conductor Package (CD03) for Supply of ACSR MOOSE Conductor for part of Diding – Dhalkebar – Bathnaha Transmission Line corresponding to Tower Package- TW02; associated with Arun-3 HEP in Nepal. | | | | |
| 1. | (GRAND SUMMARY): Total Amount(Schedule-1+ Schedule-2) | | | |
| a. | Total Amount (Including all Taxes & Duties) Schedule-1 | Currency to be mentioned by bidder | | |
| b. | Total Amount (Including all Taxes & Duties) Schedule-2 | Currency to be mentioned by bidder | | |
| | Bidder's Name and Address: | | To: | |
| | | | O/o Chief Engineer (P&C), SAPDC, Arun-3 HEP, Satluj Bhawan, Arun Sadan, Tumlingtar, Distt. Sankhuwasabha, Nepal Ph. +977-29-575154, Mob.: +977- 9852099789/+91-9816072198. | |
| | | | For and on behalf of the bidder /Supplier | |
| |  | | | |
| | (Name, Designation & Signature of authorized representative of the Bidder/Supplier, along with his name, Seal of Company) | | | |



| | |
|---|--------------------|
| SPEC. NO.: SAPDC/P&C/Arun-3HEP/CD03/2023 (CD03) | Schedule-6a |
| Conductor Package (CD03) for Supply of ACSR MOOSE Conductor for part of Diding – Dhalkebar – Bathnaha Transmission Line corresponding to Tower Package- TW02; associated with Arun-3 HEP in Nepal. | |
| NOT APPLICABLE | |





| | |
|---|--------------------|
| SPEC. NO.: SAPDC/P&C/Arun-3HEP/CD03/2023 (CD03) | Schedule-6b |
| Conductor Package (CD03) for Supply of ACSR MOOSE Conductor for part of Diding – Dhalkebar – Bathnaha Transmission Line corresponding to Tower Package- TW02; associated with Arun-3 HEP in Nepal. | |
| NOT APPLICABLE | |





SPEC. NO.: SAPDC/P&C/Arun-3HEP/CD03/2023 (CD03)

Bid Form 2nd Envelope(Envelope-II)

BID FORM (Second Envelope) (Envelope-II)

Bid Proposal Ref. No.

Date :

To: To:

O/o Chief Engineer (P&C),
SAPDC, Arun-3 HEP, Satluj Bhawan, Arun Sadan, Tumlingtar, Distt. Sankhuwasabha, Nepal Ph. +977-29-575154, Mob.: +977-9852099789/+91-9816072198.

Name of Contract : **Conductor Package (CD03) for Supply of ACSR MOOSE Conductor for part of Diding – Dhalkebar – Bathnaha Transmission Line corresponding to Tower Package- TW02; associated with Arun-3 HEP in Nepal.**

SPEC. NO.: SAPDC/P&C/Arun-3HEP/CD03/2023 (CD03)

Dear Ladies and/or Gentlemen,

1.0 In continuation of First Envelope of our Bid, we hereby submit the Second Envelope of the Bid, both of which shall be read together and in conjunction with each other, and shall be construed as an integral part of our Bid. Accordingly, we the undersigned, offer to design, manufacture, test, deliver, install and commission (including carrying out Trial Operation, Performance & Guarantee Test as per provision of Technical Specification) the Facilities under the above-named package in full conformity with the said Bidding Documents for the sum of INR/- and NPR/- or such other sums as may be determined in accordance with the terms and conditions of the Bidding Documents.

The above amounts are in accordance with the price schedules attached herewith and are made part of this bid.

2.0 **Price Schedules**

2.1 In line with the requirements of the Bidding documents, we enclose herewith the following Price Schedules, duly filled - in as per your proforma:

Schedule 1a : Goods to be supplied from abroad (i.e. Outside Nepal) including Type Test Charges for Type Tests to be conducted abroad

Schedule 1b : Goods to be supplied from within Nepal, including Type Test Charges

Schedule 2 : Port handling and Custom clearance of Goods supplied from abroad, if applicable & Local/inland Transportation, In-transit insurance and loading.



- Schedule 3 : Supervision of Installation Services [**Not Applicable**]
- Schedule 4 : Taxes and Duties included in Schedule 1 to 3 above
- Schedule 5 : Grand Summary (Schedule Nos. 1 to 3)
- Schedule 6a : Break-up of Type Test Charges for Type Tests to be conducted abroad
[Not Applicable]
- Schedule 6b : Break-up of Type Test Charges for Type Tests to be conducted in Nepal.**[Not Applicable]**

- 2.2 We are aware that the Price Schedules do not generally give a full description of the Work to be performed under each item and we shall be deemed to have read the Technical Specifications and other sections of the Bidding Documents and Drawings to ascertain the full scope of Work included in each item while filling-in the rates and prices. We agree that the entered rates and prices shall be deemed to include for the full scope as aforesaid, including overheads and profit
- 2.3 We declare that as specified in Clause 11.5, Section –II: ITB, Vol.-I of the Bidding Documents, prices quoted by us in the Price Schedules shall be subject to Price Adjustment during the execution of Contract in accordance with Appendix-2 (Price Adjustment) to the Contract Agreement
- 2.4 We understand that in the price schedules, where there are errors between the total of the amounts given under the column for the price Breakdown and the amount given under the Total Price, the former shall prevail and the latter will be corrected accordingly. We further understand that where there are discrepancies between amounts stated in figures and amounts stated in words, the amount stated in words shall prevail. Similarly, any discrepancy in the total bid price and that of the summation of Schedule price (price indicated in a Schedule indicating the total of that schedule), the total bid price shall be corrected to reflect the actual summation of the Schedule prices.
- 2.5 We declare that items left blank in the Schedules will be deemed to have been included in other items. The TOTAL for each Schedule and the TOTAL of Grand Summary shall be deemed to be the total price for executing the Facilities and sections thereof in complete accordance with the Contract, whether or not each individual item has been priced.
- 3.0 We confirm that except as otherwise specifically provided our Bid Prices in this Second Envelope include all taxes, duties, levies and charges as may be assessed on us, our Sub-Contractor/Sub-Vendor or their employees by all municipal, state or national government authorities in connection with the Facilities, in and outside of Nepal.
- 3.4 We confirm that we shall [or our Associate (*applicable for Foreign Bidder*)] also get registered with the concerned Sales Tax Authorities, in all the states where the project is located.



- 3.5 We confirm that no Sales Tax/VAT in any form shall be payable by you for the bought out items which shall be despatched directly by us under the First Contract to the project site. However, you will issue requisite Sales Tax declaration/Vatable forms in respect of such bought out items, on production of documentary evidence of registration with the concerned Sales Tax Authorities.
- 4.0 # (For Joint Venture only) We, the partners of Joint Venture submitting this bid, do agree and confirm that in case of Award of Contract on the Joint Venture, we shall be jointly and severally liable and responsible for the execution of the Contract in accordance with Contract terms and conditions.
- 4.0 # (For Joint Venture only) We, the partners of Joint Venture submitting this bid, do agree and confirm that in case of Award of Contract on the Joint Venture, we shall be jointly and severally liable and responsible for the execution of the Contract in accordance with Contract terms and conditions.
- 5.0 We, hereby, declare that only the persons or firms interested in this proposal as principals are named here and that no other persons or firms other than those mentioned herein have any interest in this proposal or in the Contract to be entered into, if the award is made on us, that this proposal is made without any connection with any other person, firm or party likewise submitting a proposal is in all respects for and in good faith, without collusion or fraud.

Thanking you, we remain, Yours faithfully, For and on behalf of



For and on behalf of the bidder /Supplier

(Name, Designation & Signature of authorized representative of the Bidder/Supplier, along with his name, Seal of Company)

Date :

Place :

Please provide additional information of the Bidder

Business Address :

Country of
Incorporation :
State/Province to be
indicated :
Name of Principal
Officer :
Address of Principal
Officer :