

एसजेवीएन अरूण-3 पाँवर डवलपमेंट कंपनी प्रा. लि.
SJVN Arun-3 Power Development Company Pvt. Ltd.

(एसजेवीएन की पूर्ण स्वामित्व वाली अधीनस्थ कंपनी)

(A wholly owned subsidiary of SJVN)

900 मेगावाट अरूण-3 जलविद्युत परियोजना
900 MW Arun-3 Hydro Power Project
Regd. No.: 111808/69/070



Ref. No.: SAPDC/P&C/Arun-3HEP/PPR-191/2025-130

Date: 30.01.2025

NOTICE INVITING QUOTATIONS (NIQ)

Sealed quotations are herewith invited by SJVN Arun-3 Power Development Company Pvt. Ltd. (SAPDC/Employer) from the eligible Bidder/Suppliers of Nepal for “**Supply, Transportation & Installation of desk benches (As per Specification at Annexure-B, Scope at Annexure-C & Drawing at Annexure-F) at Shree Jalpa Secondary School, Chichila RM-03, Dadagaun, Distt. Sankhuwasabha, Nepal (PPR-191/2025)**” as per the details provided here-in:-

Sr. No.	Description	Remarks
1.	Bill of Quantities (BOQ)	Refer Annexure 'A'
2.	Technical Specifications	Refer Annexure 'B'
3.	Scope of work	Refer Annexure 'C'
4.	Form of declaration	Refer Annexure 'D'
5.	Bank Account Details	Refer Annexure 'E'
6.	Tender Drawing	Refer Annexure 'F'

TERMS & CONDITIONS (T&C):

1. Minimum Qualifying Requirements:

- Average Annual turnover during the last three Financial years, ending 15th July, 2024 should be at least i.e. NPR 2,28,600/-

In support of above, Audit Reports and/or tax clearance certificate obtained from the Inland Revenue Department or documents showing submission of tax returns for the past three financial years shall be furnished by the Bidder.

2. Submission of Bid:-

The bidder must submit the bid in the following **two separate sealed envelopes {PART-I (Envelope-1) & PART-II (Envelope-2)}** clearly indicating the contents therein duly super scribed as under and these two envelopes should be enclosed in a single sealed envelope/cover super scribed as “**Supply, Transportation & Installation of desk benches (As per Specification at Annexure-B, Scope at Annexure-C & Drawing at Annexure-F) at Shree Jalpa Secondary School, Chichila RM-03, Dadagaun, Distt. Sankhuwasabha, Nepal (PPR-191/2025)**” and submitted at the address of the undersigned and must reach this office through courier or by post or by hand on or before **20.02.2025 by 1530 Hrs.** and same shall be opened on **20.02.2025 at 1600 Hrs.** in presence of authorized representative of firms who choose to attend.

Further, In the “Techno-Commercial” part *{i.e in PART-I (Envelope-1)}* of the bid the bidder shall not give any indication about the bid price in any manner whatsoever. Non-compliance of this provision may result in the rejection of bid.

PART-I (Envelope-1):-

- i. Original Earnest Money Deposit (EMD) (as per Sr. No.9).
- ii. The firm shall submit PAN/VAT/Registration certificate.
- iii. Duly filled in & signed ‘Form of declaration’ as per Annexure-C.
- iv. Bank Account Details as per Annexure-D.
- v. Bidder may submit the image of item(s) (if any) for which quoting the rates. However, that image will be considered only for reference not for evaluation and/or comparison.

PART-II (Envelope-2):-

Price bid:- Comprising of Price Bid at Annexure-A i.e., duly filled, signed and stamped in Bill of Quantities (BOQ).

3. Opening of Bid:-

The bid shall be opened in the following sequence:-

- i. First, the envelope Part-I shall be opened.
Part –II (Price Bid) of responsive bidder(s) shall be opened on same day, if no clarification is required from the firm(s)/agency(ies). In case clarification is sought from the firm(s)/agency(ies), separate intimation shall be given through notification on the websites for opening of Price Bid(s) of responsive bidder(s).

4. No material and T&P will be issued by SAPDC.

5. Completion period:

The total time for supply, Transportation and installation of item(s) is **120 days** (excluding time taken by SAPDC for approval of sample) from the date of issuance of Supply order/LOA. Sample of each item shall be approved by SAPDC before manufacturing & supply of units in bulk. Further, consignment may also be inspected before dispatch, if required by SAPDC.

6. **Bid Validity:** The bid (s) shall be valid for 90 days from the opening of bid(s).

7. Prices:-

- i. The Bidder/Suppliers shall offer rates & prices “on Firm Price Basis”.
- ii. The quoted rates for item(s) shall be including all other taxes & duties Including VAT & Supply, transportation, loading, unloading and installation etc. charges complete in all respect as per scope of work. SAPDC shall not bear anything extra on this account.
- iii. Any statutory variation in the rate of taxes after the last date of submission of bid (if any), during the currency of the contract including extension thereof shall be reimbursed/adjusted on production of documentary proof.
- iv. Rates and Offered discount (if any) should be filled in both figures and words. In case of ambiguities in between the rate/ Offered discount in figures and the rate/ Offered discount in words, the rate/Offered discount quoted in words shall prevail and the amount shall be corrected accordingly. The SAPDC reserves the right to adjust arithmetical or other errors in any tender/quotation in the way which it considers suitable.

- v. Further, only unconditional discount offered at appropriate place in the BOQ shall only be considered for evaluation of the bid, discount offered at any other place or in any other document/letter submitted by the bidder along with the bid shall not be considered for the purpose of evaluation as well as award. Further, the bidder shall quote rate and amount inclusive of VAT, any other charges/taxes/VAT mentioned at any other place/document/letter by the bidder/supplier shall also for not be considered evaluation as well as award.
- vi. The percentage (%) offered discount should be filled in both figures and words. However, **if bidder will not Offered any discount on their quoted rate i.r.o any/all item(s) of Bill of Quantities (BOQ) at Annexure-A then the bidder must mention as Nil.**

8. **Payment:**

- i. 80% (Eighty) Payment of the contract price shall be made after the receipt of item(s)/material/good(s) in full quantity & in good condition, on submission of bill and inspection report issued by Officer-in-Charge/Engineer-in-Charge (OIC/EIC).
- ii. 15% (Fifteen) payment of Contract Price shall paid after the successfully installation items in all respects and submission of satisfactory performance certificates by EIC/OIC.
- iii. Five percent (5%) amount of the contract price may be retained by SAPDC against performance security (In the event of non-submission of Performance security by the successful bidder), which shall be released after submission of Performance security in terms of NIQ Clause 12. or released within 28 days after completion of guarantee / warranty/defect liability period reckoned from the supply of item(s)/material/goods upon recommendation and submission of satisfactory performance certificates by OIC (as the case may be). No interest shall be paid on the retained amount.

9. **Earnest Money Deposit (EMD):**

- a. Earnest Money Deposit (EMD) amounting to **NPR 16,000/-** shall be submitted in the shape of **Bank Draft** (in original)/**Manager Cheque** (in original)/**FDR** (in original) (duly pledged in favour of SAPDC-NPR CONSTRUCTION ACCOUNT) in favor of SAPDC-NPR CONSTRUCTION ACCOUNT payable at Khandbari.

Or,

Bank Guarantee (in original) in favor of SJVN Arun-3 Power Development Company Pvt. Ltd. (SAPDC) Acceptable to SAPDC for an amount as mentioned herein-above.

Earnest Money Deposit shall remain valid for **135 days** from the last date of submission of bids as stated in the invitation to bid. Bank Guarantee may be in the format provided in tender document (**Annexure-I**).

Or,

Alternatively, Payment against EMD may also be made directly in the account of SAPDC as below. However, proof of same shall be submitted by the Firm/agency with the Proposal in Part-I (Envelope-I):

NPR Account Details:
Everest Bank Limited
Name: SAPDC-NPR CONSTRUCTION ACCOUNT.
Acc. No. 00800105200477
Swift Code: EVBLNPKA

Bidders are advised and shall be responsible to ensure the receipt of net amount (excluding bank transfer charges) in above account in case of Indian bidder before last date of submission of bids.

However, if Bidder/Firm opt for submission of Earnest Money Deposited (EMD)/Bid Security directly in the bank account of SAPDC, then the documentary evidence/ proof of same (swift statement/ transfer statement/ account statement) has to be submitted along with technical bid in Part-I.

Any bid not accompanied by an acceptable Earnest Money Deposit shall be declared non-responsive and outrightly rejected by the Employer and their Part-II (Price Bid) bid shall not be opened.

- b. EMD of the bidder shall be forfeited:
- i. If bid withdrawn or amends its bid or impairs or derogates from the bid in any respect in the interval between the bid submission deadline and the expiration of the bid validity period.
or
 - ii. Adopts corrupt or fraudulent practices
or
 - iii. Does not accept the correction of the Bid Price.
or
 - iv. EMD of the successful bidder(s)/supplier(s) shall be forfeited, in the event of non-compliance of Supply Order/Letter of Acceptance (LOA).
or
 - v. fails or refuses to furnish the Performance Security, in accordance with the NIQ/LOA.
- c. Bidder may modify or amends its bid or withdraw its bid after submission and before the prescribed deadline for bid submission.
- d. The EMD of unsuccessful Firm(s)/Agency(ies) shall be released within 30 days without any interest after declaration of non-responsive. Further, EMD of responsive bidders (other than L1 bidder) shall be released within 30 days without any interest after the issuance of Letter of Acceptance of successful Firm(s)/Agency(ies).
- e. The EMD of the successful bidder shall be released within 28 days after submission of performance security, required to be submitted in terms of NIQ Clause 12 or after retention of amount as per NIQ Clause 8(iii)(as the case may be).
- f. No interest shall be payable by SAPDC on EMD

10. **Award Criteria:**

- (i) The bid shall be evaluated on overall basis and the award shall be made based on the lowest rate/Amount quoted by the Bidder/Supplier for whole Package/assignment as per **Annexure-A** in the Bill of Quantities.
- (ii) If, Bidder(s) quote Zero/Nil/left Blank/(-) rate(s) against any item(s) of BOQ then it will be presumed that bidder(s) has/have quoted the rate(s) for that item(s) in any other item(s) of the BOQ. In that case Zero (0) rate(s) shall be considered for the purpose for evaluation as well as award.

11. **Liquidated Damages (LD):** In case of delay in Supply, Transportation & Installation of item(s)/furniture, LD @ 0.33 % of contract price per day of delay in completion shall be levied subject to maximum of 10% of the contract price (cumulative or individual LD in terms of clause at Sr.No.11 & at Sr.No.15).

In case the supplier fails to supply the material within 150 days from the date of issue of supply order, SAPDC reserves the right to terminate the supply order and EMD shall be forfeited and the forfeited amount shall be as per clause 9b (iv) of NIQ.

12. **Performance Security Deposit:**

- 12.1 Within 28 (twenty eight) days from the date of issue of the Supply Order/Letter of Acceptance (LOA), the successful bidder(s) shall deliver to the Employer a Performance Security equal to **5% (five percent)** of the Contract Price valid till 60 days beyond Contract period and till successful completion of Guarantee/Warranty period (if applicable).
- 12.2 The Performance Security Deposit shall be in the form of a demand draft / Banker Cheque in favor of "**SAPDC-NPR Construction Account**" payable at Khandbari/ FDR (duly pledged in favor of **SJVN Arun-3 Power Development Company Private Limited (SAPDC)**)/The bidder may submit the same in the form of irrevocable, valid and fully enforceable Bank Guarantee in favor of **SJVN Arun-3 Power Development Company Private Limited (SAPDC)** in the prescribed form (Ref Annexure-II) from a Class A bank situated in Nepal acceptable to SJVN Arun-3 Power Development Company Private Limited.
- 12.3 Failure of the successful Bidder to comply with the requirements of Clause 12.1 shall constitute sufficient grounds for cancellation of the award and forfeiture of the Earnest Money Deposit. He may also be debarred from participating in bids invited by the Project for one year.
- 12.4 The performance guarantee will be returned by the EIC (Engineer-in-Charge)/Officer-In-Charge (OIC) to the contractor/Supplier within 28 days after completion of contract without any interest, after issuance of successful Completion Certificate, on completion of Guarantee/Warranty period.
- 12.5 In case of delay in submission of performance security beyond 28 days as provided in clause 12.1 above, interest @ SBI, India one-year MCLR +200 Basis points applicable on the date of bid submission shall be charged on per day basis up to the date of delay in submission. However, delayed acceptance beyond 56 days shall be at the sole discretion of SAPDC and Letter of Acceptance/ award (LOA) shall be subject to cancellation and forfeiture of EMD along with other suitable action as per NIQ.

- 12.6 In case, the last day of submission of Performance Security happens to be a bank holiday, the last day of submission shall be the next working day.
- 12.7 The notification of Award (NOA)/Letter of Acceptance (LOA) will constitute the formation of the Contract and further subject only to the furnishing of a performance security.
13. **Force Majeure:** The term "Force Majeure" shall herein mean riots (other than among the Vendor's employees), Civil Commotion (to the extent not insurable), war (whether declared or not), invasion, act of foreign enemies, hostilities, civil war, rebellion, revolution, insurrection, military or usurped power, damage from aircraft, nuclear fission, acts of God, such as earthquake (above 7 magnitude on Richter Scale), lightning, unprecedented floods, fires not caused by Vendor's negligence and other such causes over which the Vendor has no control and are accepted as such by the Officer-in-Charge (OIC), whose decision shall be final and binding. In the event of either party being rendered unable by Force Majeure to perform any obligation required to be performed by them under this contract, the relative obligation of the party affected by such Force Majeure shall be treated as suspended for the period during which such Force Majeure cause lasts, provided the party alleging that it has been rendered unable as aforesaid, thereby shall notify within 10 days of the alleged beginning and ending thereof giving full particulars and satisfactory evidence in support of such cause. Extension of time without levy of LD shall be provided during the period of occurrence of Force Majeure event, however no cost compensation shall be provided.
14. **Packing:** The supplier, wherever applicable shall properly pack and stack all materials/goods in such a manner as to protect them from deterioration and damage during transportation. The supplier shall be responsible for all damage due to improper packing.
15. **Replacement:** If the material/goods or any portion thereof is damaged or lost during transit, SAPDC shall give notice to the supplier setting forth particulars of such material/goods damaged or lost during transit. The replacement of such material/goods shall be affected by the supplier within 60 days (reckoned from the date of notice given by SAPDC to the supplier), to avoid unnecessary delay in the intended usage of the materials free of cost to the SAPDC.
- Further, if replacement shall not be made within the above said time, then the additional LD @ 0.33% of contract price per day of delay shall be levied.
- The levied LD shall be subject to maximum of 10% of the contract price (cumulative or individual LD in terms of clause at Sr.No.11 & at Sr.No.15)
16. **Rejection:** In the event that any of the material/goods supplied by the supplier is found defective in material or workmanship or otherwise not in conformity with the specification, SAPDC shall either reject the material/good(s)/Item(s) or request the supplier in writing to rectify/replace the same. The supplier, on receipt of such notification shall rectify/replace (As directed by the OIC/EIC) the defective material/good(s)/item(s) free of cost to the SAPDC. Decision of OIC/EIC (SAPDC) shall be final and binding on the supplier(s).
17. **Demurrage, Wharfage etc.:** All demurrage, wharfage and other expenses incurred due to delayed clearance of the material/goods or any other reason shall be on the account of the supplier.

18. **Guarantee/Warranty/Defect liability period:** Guarantee/Warranty/Defect liability period shall be minimum for 12 months In case of any complaint/repair required during Guarantee/ Warranty period/ Defect liability, the vendor/ supplier will respond within Seven days and ensure rectification within two weeks' time from the date of lodging of complaint. The supplier shall either rectify or replace the defective item(s)/material(s) free of cost to SAPDC within Guarantee/Warranty period.

If, supplier fails to perform such obligation(s), then the retained amount as per clause No.8(iii)/Performance security, may be forfeited by the SAPDC.

19. **Consignee:** The material/ goods under this Contract shall be dispatched to Consignee as mentioned in BOQ/ scope of work. However, Chief Engineer (Store) or shall be the consignee for this contract and payment and other codal formalites shall be done through Chief Engineer (Store) for all the material. The address of consignee shall be as following below:

Head (Store),

Satluj Bhawan, Arun Sadan,
SAPDC, Tumlingtar,
Distt. Sankhuwasabha, Nepal.
(Mobile No.: 9767814205)
Email: store.sapdc@sjvn.nic.in

20. **Resolution of Dispute:** In case of any dispute or difference that arises out of the subject cited supply, the same shall be referred to the Sole Arbitrator, who shall be appointed by the CEO, Arun-3 HEP, SAPDC, Tumlingtar. The award of the arbitrator shall be final and binding on both the parties.

Courts of Chainpur (Nepal) shall have exclusive Jurisdiction for adjudication upon the dispute arising out of the subject cited supply between the parties.

21. Corrigendum/Addendum, if any to NIQ shall be uploaded only on web portals <https://sjvn.nic.in> or <https://www.sapdc.com.np>. The bidders may keep watch on the said portals.

22. SAPDC reserves the right to reject any or all the tenders without assigning any reason thereof.

23. SAPDC reserves the right to increase / decrease the quantity at the time of placing the supply order.

24. For any enquiry/clarification for submission of bid and any other information, the Bidders may contact to:-

Name	Designation	Contact No.	Address
Er. Parminder Kumar	Chief Engineer (P&C)	Tel no: +977-029- 575154	Satluj Bhawan, Arun Sadan, SAPDC, Tumlingtar, Distt. Sankhuwasabha, Nepal.
Er. Neeraj Kumar	Manager (Civil)		

25. **General Information:**

To reach the site of Arun-3 HEP Nepal the nearest broad-gauge railway station is Jogbani, Bihar (India) and further by road up to Tumlingtar is about nearly 264 Km. Jogbani in Bihar is a city of India with Nepal border and is just 6.00 Km. from Biratnagar (a major industrial town of Nepal).

Road conditions in different road segment en-route are as under:

- a. Biratnagar to Hile: Hile is located at 108 Km from Biratnagar and the existing road up to Hile is black topped road in good condition.
- b. Hile-Pakhribas-Tumlingtar: This route is about 55 Km and the road fully is black topped.
- c. Tumlingtar is also connected to Kathmandu and Biratnagar by air by around thirty-five minutes journey.
- d. Tumlingtar to Power House Site (Pukhuwa): This route is about 60 Km and the road is mostly kaccha road except Tumlingtar to Khandbari(15 KM) which is black topped.

For & on the behalf of SAPDC

Sd/-

Chief Engineer (P&C)

Satluj Bhawan, Arun Sadan,

SAPDC, Tumlingtar,

Distt. Sankhuwasabha, Nepal

Ph. +977-29-575154,

e-mail Address: pnc.sapdc@sjvn.nic.in

BILL OF QUANTITIES(BOQ)

Name of Work/Assignment: (PPR-191/2025) **“Supply, Transportation & Installation of desk benches (As per Specification at Annexure-B, Scope at Annexure-C & Drawing at Annexure-F) at Shree Jalpa Secondary School, Chichila RM-03, Dadagaun, Distt. Sankhuwasabha, Nepal”**

Sr. No	Description of items	Unit	Qty	Rate (NPR) Including VAT, Supply, Transportation & Installation Charges etc.		Amount (NPR) Including VAT, Supply, Transportation & Installation Charges etc.
				In Figures	In Words	
1.	Supplying, transportation and installation of school desk of following sizes made of local wood (Chilaune/Rudrax/Lapsi) and 18mm commercial ply, formica laminate as per attached drawing, priming and painting complete in all respects. (As per Specification at Annexure-B, Scope at Annexure-C & Drawing at Annexure-F)					
i.	Length 5’-6”, width 2’-3”, 2’-0” height (As per Specification at Annexure-B, Scope at Annexure-C & Drawing at Annexure-F)	Each	20			
ii.	Length 5’-6”, width 2’-3”, 2’-3” height (As per Specification at Annexure-B, Scope at Annexure-C & Drawing at Annexure-F)	Each	20			
iii.	Length 6’-0”, width 2’-4”, 2’-5” height (As per Specification at Annexure-B, Scope at Annexure-C & Drawing at Annexure-F)	Each	30			

Total Amount (NPR) Including VAT, Supply. Transportation & Installation Charges etc.			
Overall Discount offered, if any (%)	In Figure	In Words	
Net Amount after offered discount (NPR)			

Note:

1. Only unconditional discount offered at appropriate place in the BOQ shall only be considered for evaluation of the bid, discount offered at any other place or in any other document/letter submitted by the bidder along with the bid shall not be considered for the purpose of evaluation as well as award. Further, the bidder shall quote rate and amount inclusive of VAT, any other charges/taxes/VAT mentioned at any other place/document/letter by the bidder/supplier shall also for not be considered evaluation as well as award.
2. Bidder may see the drawings of items for reference at Annexure-F.

Date:

Place:

For and on behalf of the bidder /Supplier

.....

**(Signature of authorized representative of the Bidder/
Supplier, along with his name, Seal of Company)**

SPECIFICATIONS

Desk benches are to be supplied as per specification specified in BOQ and as per specification of drawing.

LIST OF APPROVED MAKES FOR DESK BENCH MATERIALS / ITEMS:

UNLESS OTHER WISE SPECIFICALLY MENTIONED ALL MATERIALS TO BE USED SHALL CONFORM TO INDIAN/NEPALI STANDARD SPECIFICATIONS.

Sr. No.	Items	Approved Make
List of Approved Makes for Desk Bench Works:		
1.	Wood	Local wood, Chilaune/Rudrax/Lapsi or equivalent as approved by EIC/OIC.
2.	Plywood/ Commercial Ply	18 mm commercial ply, Kohinoor/Shikhar plywood or Equivalent Nepal Brand / Standard (NS)or equivalent as approved by EIC.
3.	Wood Printer	Chapra Polish, Nerolac, Asian Paint or equivalent as approved by EIC/OIC.
4.	Wood Paints	Dulux, Burger Paint, Nerolac, Asian Paint or equivalent as approved by EIC/OIC.
5.	Laminate	Formica Sunglasses or Equivalent Nepal Standard (NS) or Equivalent as approved by EIC/OIC.

SCOPE OF WORK (PPR-191/2025)

NAME OF WORK: “Supply, Transportation & Installation of desk benches at Shree Jalpa Secondary School, Chichila RM-03, Dadagaun, Distt. Sankhuwasabha, Nepal (PPR-191/2025)”

1.0 The detailed scope of work shall include but not be limited to the following:

All works are required to be carried out as per specifications specified in BoQ. In addition to this:

- a. Submission of detailed local wood and paint scheme for all items/ components (internal and external) to EIC/OIC before the start of work.
- b. The contractor shall make his own arrangement for material and equipment’s transportation, loading, unloading, and electricity required for the execution of work at his own risk and cost.

2.0 Supply, Transportation & Installation of Desk Bench at the following address:

**Shree Jalpa Secondary School,
Chichila Rural Municipality-03, Dadagaun,
Sankhuwasabha, Nepal**

FORM OF DECLARATION

M/s------(name of Bidder/Supplier)

having its registered office at -----
(hereinafter referred to as ‘the Bidder/Supplier’) having carefully studied all Terms and conditions, scope of work & Technical specifications, BOQ etc. and all corrigendum (if any) pertaining to the **“Supply, Transportation & Installation of desk benches (As per Specification at Annexure-B, Scope at Annexure-C & Drawing at Annexure-F) at Shree Jalpa Secondary School, Chichila RM-03, Dadagaun, Distt. Sankhuwasabha, Nepal (PPR-191/2025)”** the local and site conditions and having undertaken to execute the said works.

DO HEREBY DECLARE THAT:

1. The Bidder is familiar with all the requirements of the Contract.
2. The Bidder has not been influenced by any statement or promise of any person of the Employer but only the Contract conditions.
3. The Bidder undertakes that the information furnished in the Bid is true and correct in all respects.
4. The Bidder undertakes that all the documents uploaded along with the NIQ have been read and there is no deviation from the terms and conditions of the NIQ including Corrigendum/Addendum(if any).

Date:

For and on behalf of the bidder /Supplier

.....

(Signature of authorized representative of the Bidder/Supplier, along with his name, Seal of Company)

BANK ACCOUNT DETAILS (PPR-191/2025)

Sr. No.	Particulars	#To be filled by bidder(s)
1.	Name of Bidder as per Bank record	
2.	Bank account number	
3.	Bank name	
4.	Branch address	

#Copy of cancelled cheque may also be attached

For and on behalf of the bidder /Supplier

.....

(Signature of authorized representative of the Bidder/Supplier, along with his name, Seal of Company)

FORM OF BANK GUARANTEE FOR EARNEST MONEY DEPOSIT

(Refer clause 9 of NIQ)

WHEREAS _____ (Name of Bidder) (hereinafter called “the Bidder”) has submitted his bid dated _____ (date) for “**Supply, Transportation & Installation of desk benches (As per Specification at Annexure-B, Scope at Annexure-C & Drawing at Annexure-F) at Shree Jalpa Secondary School, Chichila RM-03, Dadagaun, Distt. Sankhuwasabha, Nepal (PPR-191/2025)**”.

SEALED with the Common Seal of the said Bank this ___ day of _____ (Month and Year).

THE CONDITIONS of this obligation are:

1. If bid withdrawn or amends its bid or impairs or derogates from the bid in any respect in the interval between the bid submission deadline and the expiration of the bid validity period.

or

2. If the Bidder having been notified of the acceptance of his Bid by the SJVN Arun-3 Power Development Company Private Limited, during the period of bid validity.

a. Does not accept the correction of the Bid Price.

or

b. Adopts corrupt or fraudulent practices

or

c. Non-compliance of Supply Order/Letter of Acceptance (LOA).

Or

d. fails or refuses to furnish the Performance Security, in accordance with the NIQ/LOA.

We undertake to pay to the SJVN Arun-3 Power Development Company Private Limited, (NPR.....)(In words.....) the above amount upon receipt of its first written demand without the SJVN Arun-3 Power Development Company Private Limited having to substantiate its demand, provided that in its demand the SJVN Arun-3 Power Development Company Private Limited will note that the amount claimed by it due to it owing to the occurrence of one or any of the three conditions, specifying the occurred condition or conditions.

This Guarantee will remain in force up to and including the date **135 days after the deadline for submission of Bids** as stated in the invitation to bid or as it may be extended by the SJVN Arun-3 Power Development Company Private Limited notice of which extensions(s) to the Bank is hereby waived. Any demand in respect of this Guarantee should reach the Bank not later than the above date.

DATE _____
BANK _____

SIGNATURE OF THE

WITNESS _____

SEAL _____

(Signature, name and address)

**FORM OF BANK GUARANTEE FOR PERFORMANCE SECURITY DEPOSIT
(Refer clause 12 of NIQ)**

Date:

To,

Name & Address of the Employer

We have been informed that (the “company”),
having its registered office at
..... has entered into a
Agreement on (Insert LOA No. & Date) with you for the work of
**“Supply, Transportation & Installation of desk benches (As per Specification at Annexure-
B, Scope at Annexure-C & Drawing at Annexure-F) at Shree Jalpa Secondary School,
Chichila RM-03, Dadagaun, Distt. Sankhuwasabha, Nepal (PPR-191/2025)”**.

In accordance with the terms of the AGREEMENT/Letter of acceptance (LOA), the Company is
required to submit an unconditional and irrevocable, payable on-demand bank guarantee of NPR
..... (Nepalese Rupees only), (the
"Security Amount") to SAPDC for the due and faithful performance of the Company's
obligations under the AGREEMENT (the **"Performance Security"**) and we
..... (name and address of the Bank, hereinafter called the
"Guarantor") have at the request of the Company agreed to provide such Performance Security,
being this Bank Guarantee (Performance Security) No.

On your first written demand, stating that (a) the Company is in default of its obligations under
the AGREEMENT/Letter of acceptance(LOA), or (b) the Company has not replaced this
Performance Security with another performance security issued on the same terms at least
fourteen (14) days prior to the Expiry Date (as hereinafter defined), we, the Guarantor as primary
obligor hereby expressly, unconditionally and irrevocably undertake to pay to SAPDC, without
demur, reservation, protest and any reference to the Company or the AGREEMENT the amount
specified in such demand, provided that the total of all demands shall not exceed the sum of the
Security Amount. You shall not be required to prove or show grounds for your demand or the
sum specified therein. It is clarified further that your demand shall be conclusive evidence to us
that such payment is due under the terms of the AGREEMENT. It shall not be necessary, and the
Guarantor hereby waives any necessity, for SAPDC to proceed against the Company before
presenting to the Guarantor its demand under the Performance Security.

The term of this Performance Security shall commence on the date of its issuance and shall
expire on the date **60 days beyond** the Guarantee/Warranty period (the **"Expiry Date"**).

All claims, if any, in respect of this Performance Security must be received by the Guarantor on
or before the Expiry Date.

This guarantee is subject to Uniform Rules for Demand Guarantees ICC Publication No. 758,
except that the provisions of Article 26 are hereby excluded and shall be governed by and
construed in accordance with the Laws of Nepal and will be subject to the jurisdiction of the
courts of Nepal.

The Performance Security shall not be affected by any change in the constitution of the Guarantor or of the Company.

Notwithstanding anything contained hereinabove:

- (1) Our liability under this Guarantee shall not exceed the Security Amount
- (2) Any demand may be brought by SAPDC under this Guarantee up to close of business on the Expiry Date.
- (3) We shall be liable to pay any amount under this Guarantee or part thereof only if we receive a claim or demand in writing within banking hours at our branch on or before the Expiry Date and if no such demand has been received by us by that time and date, all rights to bring any demand under this guarantee will cease.

Notwithstanding sub-section (2) and (3) above, all claims made by SAPDC on or before the Expiry Date shall, subject to sub-section (1) above, be honored by the Guarantor where payment in respect of such demands have not been made by the Expiry Date.

This guarantee (or any of its proceeds) is not assignable and is not transferable in whole or in part.

Upon payment by the Guarantor in respect of all claims or demands made by SAPDC under this Bank Guarantee on or before the Expiry Date, this guarantee automatically becomes null and void whether or not the original has been returned to us.

Signed for and on behalf of:

Name:

Designation:

Seal of the Bank:

Signed for and on behalf of:

[Note: delete the following signature block if not applicable]

[Signed for and on behalf of confirming bank in Nepal:.....]

Name:

Designation:

Seal of the Bank:

Signed for and on behalf of:

TENDER DRAWINGS

CP-10

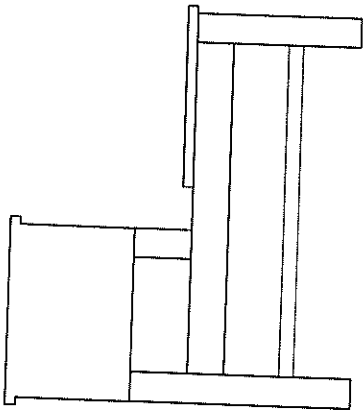

Left Side view of Bench

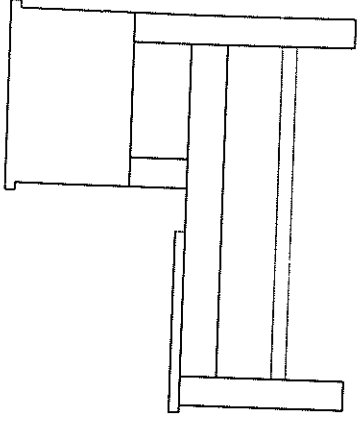

Right Side view of Bench

1

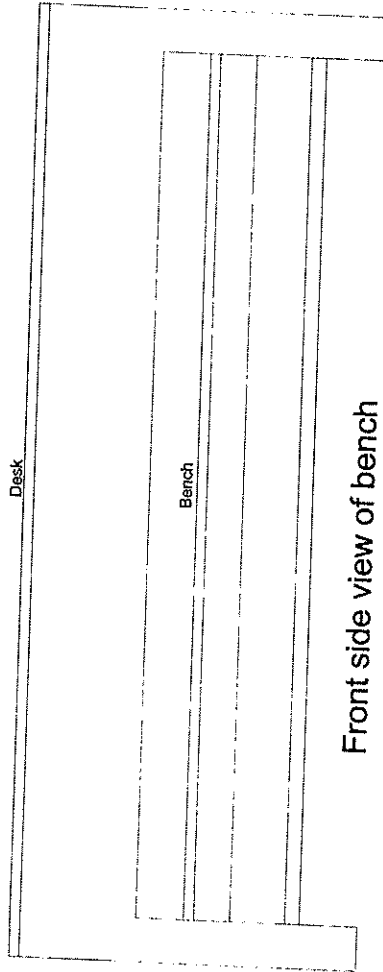

Front side view of bench

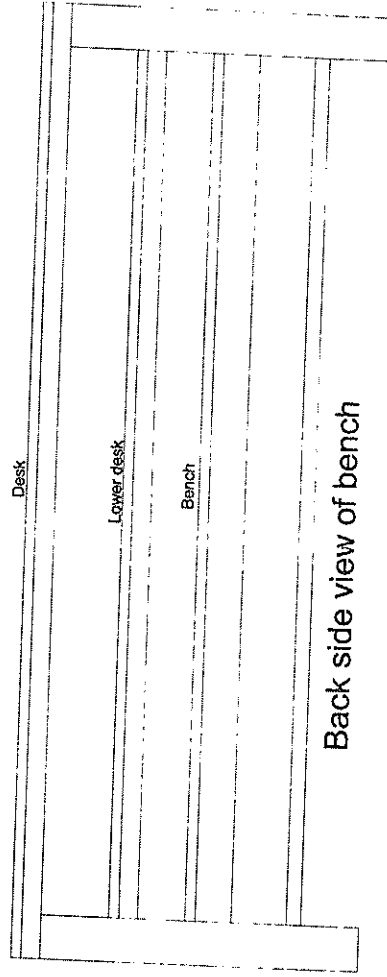

Back side view of bench

Handwritten signature

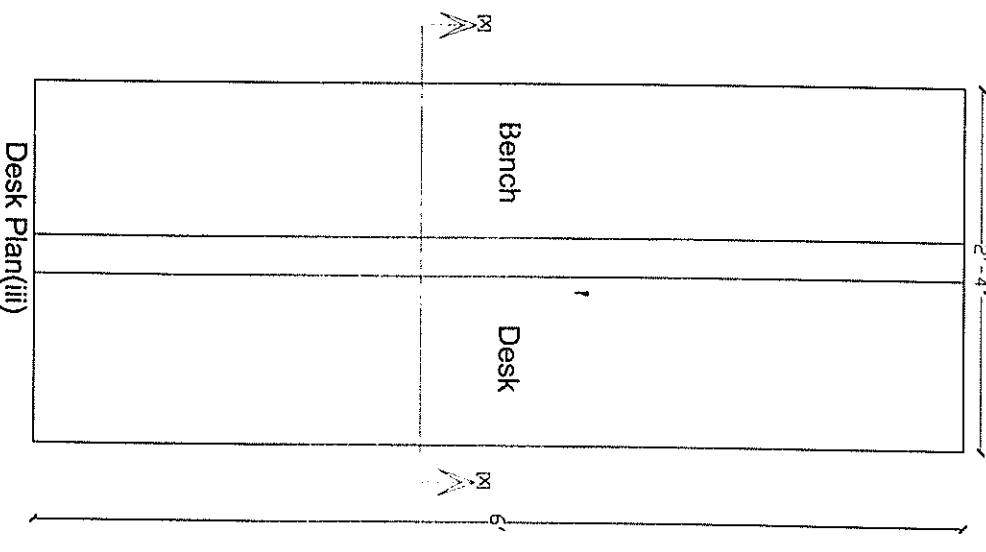
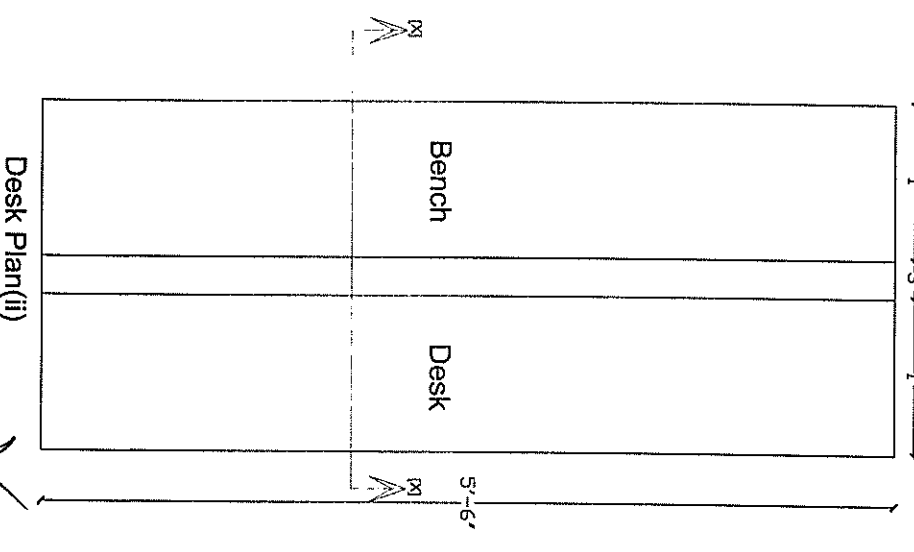
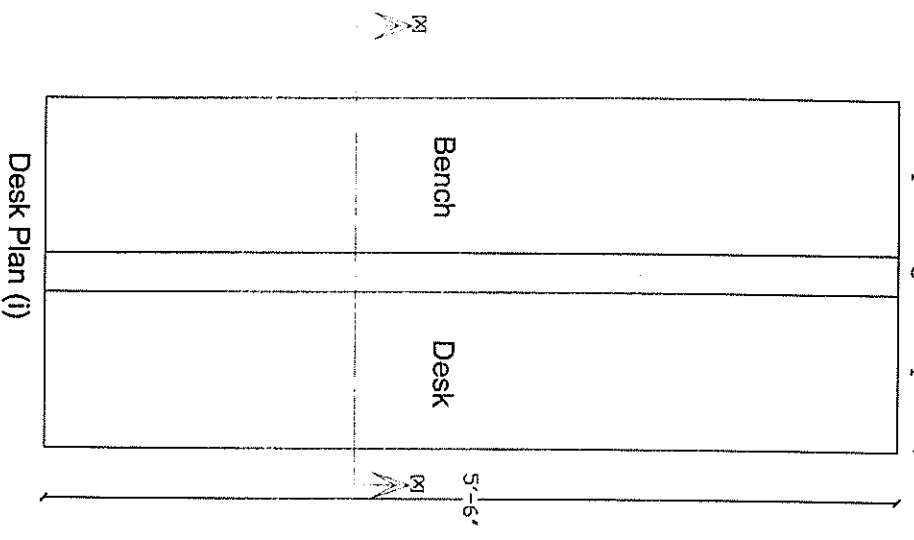
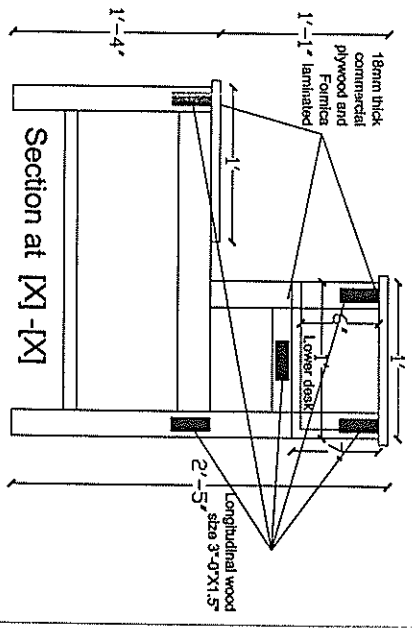
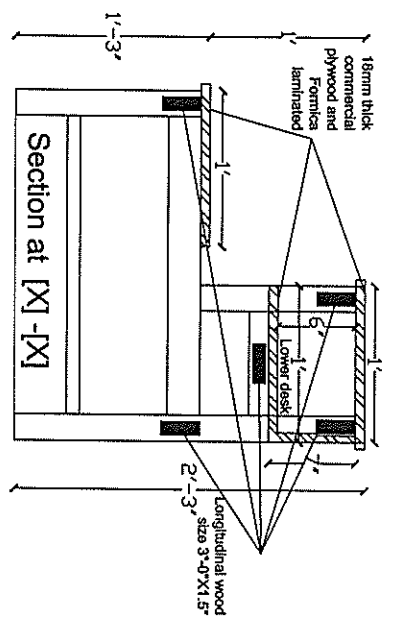
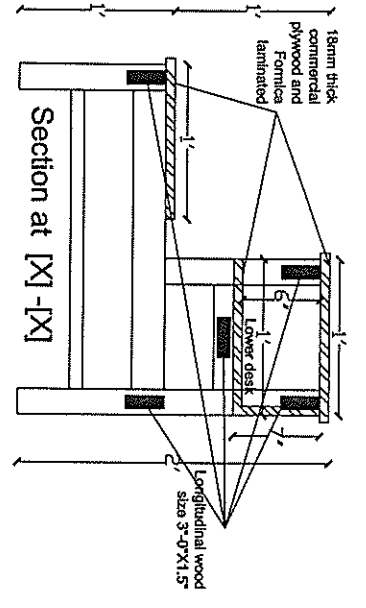

Approved